

PRODUCT MONOGRAPH

Pr PEDIAPHARM NAPROXEN SUSPENSION

naproxen

25 mg/mL Suspension

USP

Non-Steroidal Anti-Inflammatory Drug (NSAID)

Pediapharm Inc.
1 Place du Commerce, Suite 225
Verdun, QC H3E 1A2

Date of Revision:
March 15, 2018

Submission Control No: 212447

Table of Contents

PART I: HEALTH PROFESSIONAL INFORMATION.....3
SUMMARY PRODUCT INFORMATION3
INDICATIONS AND CLINICAL USE.....3
CONTRAINDICATIONS4
WARNINGS AND PRECAUTIONS.....5
ADVERSE REACTIONS.....13
DRUG INTERACTIONS17
DOSAGE AND ADMINISTRATION19
OVERDOSAGE22
ACTION AND CLINICAL PHARMACOLOGY23
STORAGE AND STABILITY23
DOSAGE FORMS, COMPOSITION AND PACKAGING24

PART II: SCIENTIFIC INFORMATION25
PHARMACEUTICAL INFORMATION.....25
CLINICAL TRIALS25
DETAILED PHARMACOLOGY25
TOXICOLOGY27
REFERENCES30

PART III: CONSUMER INFORMATION.....34

Pr PEDIAPHARM NAPROXEN SUSPENSION

naproxen

PART I: HEALTH PROFESSIONAL INFORMATION

SUMMARY PRODUCT INFORMATION

Route of Administration	Dosage Form / Strength	Clinically Relevant Non-medical Ingredients
Oral	25 mg/mL Suspension	None <i>For a complete listing see Dosage Forms, Composition and Packaging section.</i>

INDICATIONS AND CLINICAL USE

PEDIAPHARM NAPROXEN SUSPENSION (naproxen) is indicated for:

- The treatment of the signs and symptoms of osteoarthritis, rheumatoid arthritis, ankylosing spondylitis, and juvenile rheumatoid arthritis.
- The relief of minor aches and pains in muscles, bones and joints, mild to moderate pain accompanied by inflammation in musculoskeletal injuries (sprains and strains) and primary dysmenorrhea.

For patients with an increased risk of developing cardiovascular and/or gastrointestinal adverse events, other management strategies that do NOT include the use of NSAIDs should be considered first. (See CONTRAINDICATIONS and WARNINGS AND PRECAUTIONS)

Use of PEDIAPHARM NAPROXEN SUSPENSION should be limited to the lowest effective dose for the shortest possible duration of treatment in order to minimize the potential risk for cardiovascular or gastrointestinal adverse events. (See CONTRAINDICATIONS and WARNINGS AND PRECAUTIONS)

PEDIAPHARM NAPROXEN SUSPENSION, as a NSAID, does NOT treat clinical disease or prevent its progression.

PEDIAPHARM NAPROXEN SUSPENSION, as a NSAID, only relieves symptoms and decreases inflammation for as long as the patient continues to take it.

Geriatrics (> 65 years of age):

Evidence from clinical studies and postmarket experience suggests that use in the geriatric population is associated with differences in safety (see WARNINGS AND PRECAUTIONS).

Pediatrics (< 2 years of age):

PEDIAPHARM NAPROXEN SUSPENSION should not be used in children under 2 years of age. The safety and efficacy in infants younger than 2 years of age has not been established.

CONTRAINDICATIONS

PEDIAPHARM NAPROXEN SUSPENSION is contraindicated in:

- the peri-operative setting of coronary artery bypass graft surgery (CABG). Although PEDIAPHARM NAPROXEN SUSPENSION has NOT been studied in this patient population, a selective COX-2 inhibitor NSAID studied in such a setting has led to an increased incidence of cardiovascular/thromboembolic events, deep surgical infections and sternal wound complications.
- the third trimester of pregnancy, because of risk of premature closure of the ductus arteriosus and prolonged parturition
- women who are breastfeeding, because of the potential for serious adverse reactions in nursing infants
- severe uncontrolled heart failure
- known hypersensitivity to naproxen or to any of the components/excipients
- history of asthma, urticaria, or allergic-type reactions after taking ASA or other NSAIDs (i.e. complete or partial syndrome of ASA-intolerance - rhinosinusitis, urticaria/angioedema, nasal polyps, asthma). Fatal anaphylactoid reactions have occurred in such individuals. Individuals with the above medical problems are at risk of a severe reaction even if they have taken NSAIDs in the past without any adverse reaction. The potential for cross-reactivity between different NSAIDs must be kept in mind (see WARNINGS AND PRECAUTIONS: Hypersensitivity Reactions, Anaphylactoid Reactions).
- active gastric / duodenal / peptic ulcer, active GI bleeding.
- cerebrovascular bleeding or other bleeding disorders
- inflammatory bowel disease
- severe liver impairment or active liver disease
- severe renal impairment (creatinine clearance <30 mL/min or 0.5 mL/sec) or deteriorating renal disease (individuals with lesser degrees of renal impairment are at risk of deterioration of their renal function when prescribed NSAIDs and must be monitored) (see WARNINGS AND PRECAUTIONS: Renal)
- known hyperkalemia (see WARNINGS AND PRECAUTIONS: Renal, Fluid and Electrolyte Balance)
- children less than 2 years of age

WARNINGS AND PRECAUTIONS

Risk of Cardiovascular (CV) Adverse Events: Ischemic Heart Disease, Cerebrovascular Disease, Congestive Heart Failure (NYHA II-IV) (See WARNINGS AND PRECAUTIONS - Cardiovascular).

PEDIAPHARM NAPROXEN SUSPENSION is a non-steroidal anti-inflammatory drug (NSAID). Use of some NSAIDs is associated with an increased incidence of cardiovascular adverse events (such as myocardial infarction, stroke or thrombotic events) which can be fatal. The risk may increase with duration of use. Patients with cardiovascular disease or risk factors for cardiovascular disease may be at greater risk.

Caution should be exercised in prescribing PEDIAPHARM NAPROXEN SUSPENSION to any patient with ischemic heart disease (including but NOT limited to acute myocardial infarction, history of myocardial infarction and/or angina), cerebrovascular disease (including but NOT limited to stroke, cerebrovascular accident, transient ischemic attacks and/or amaurosis fugax) and/or congestive heart failure (NYHA II-IV).

Use of NSAIDs, such as PEDIAPHARM NAPROXEN SUSPENSION, can promote sodium retention in a dose-dependent manner, through a renal mechanism, which can result in increased blood pressure and/or exacerbation of congestive heart failure. (see also WARNINGS AND PRECAUTIONS: Renal, Fluid and Electrolyte Balance)

Randomized clinical trials with naproxen have not been designed to detect differences in cardiovascular events in a chronic setting. Therefore, caution should be exercised when prescribing PEDIAPHARM NAPROXEN SUSPENSION.

Risk of Gastrointestinal (GI) Adverse Events (see WARNINGS AND PRECAUTIONS: Gastrointestinal).

Use of NSAIDs, such as PEDIAPHARM NAPROXEN SUSPENSION, is associated with an increased incidence of gastrointestinal adverse events (such as ulceration, bleeding, perforation and obstruction of the upper and lower gastrointestinal tract).

General

Frail or debilitated patients may tolerate side effects less well and therefore special care should be taken in treating this population. **To minimize the potential risk for an adverse event, the lowest effective dose should be used for the shortest possible duration.** As with other NSAIDs, caution should be used in the treatment of elderly patients who are more likely to be suffering from impaired renal, hepatic or cardiac function. For high risk patients, alternate therapies that do not involve NSAIDs should be considered.

PEDIAPHARM NAPROXEN SUSPENSION is NOT recommended for use with other NSAIDs, with the exception of low-dose ASA for cardiovascular prophylaxis, because of the absence of any evidence demonstrating synergistic benefits and the potential for additive adverse reactions. (See DRUG INTERACTIONS: Drug-Drug Interactions, Acetylsalicylic acid (ASA) or other NSAIDs)

PEDIAPHARM NAPROXEN SUSPENSION (naproxen) should not be used concomitantly with the related drug naproxen sodium since they both circulate in plasma as the naproxen anion.

Carcinogenesis and Mutagenesis

There is no evidence from animal data that PEDIAPHARM NAPROXEN SUSPENSION is carcinogenic or mutagenic (see Part II, TOXICOLOGY, for animal studies).

Cardiovascular and Cerebrovascular Events

PEDIAPHARM NAPROXEN SUSPENSION is a non-steroidal anti-inflammatory drug (NSAID). Use of some NSAIDs is associated with an increased incidence of cardiovascular adverse events (such as myocardial infarction, stroke or thrombotic events) which can be fatal. The risk may increase with duration of use. Patients with cardiovascular disease or risk factors for cardiovascular disease may be at greater risk.

Caution should be exercised in prescribing PEDIAPHARM NAPROXEN SUSPENSION to patients with risk factors for cardiovascular disease, cerebrovascular disease or renal disease, such as any of the following (NOT an exhaustive list)

- **Hypertension**
- **Dyslipidemia / Hyperlipidemia**
- **Diabetes Mellitus**
- **Congestive Heart Failure (NYHA I)**
- **Coronary Artery Disease (Atherosclerosis)**
- **Peripheral Arterial Disease**
- **Smoking**
- **Creatinine Clearance < 60 mL/min or 1 mL/sec**

Use of NSAIDs, such as PEDIAPHARM NAPROXEN SUSPENSION, can lead to new hypertension or can worsen pre-existing hypertension, either of which may increase the risk of cardiovascular events as described above. Thus blood pressure should be monitored regularly. Consideration should be given to discontinuing PEDIAPHARM NAPROXEN SUSPENSION should hypertension either develop or worsen with its use.

Use of NSAIDs, such as PEDIAPHARM NAPROXEN SUSPENSION, can induce fluid retention and edema, and may exacerbate congestive heart failure, through a renally-mediated mechanism. (See WARNINGS AND PRECAUTIONS: Renal, Fluid and Electrolyte Balance).

For patients with a high risk of developing an adverse CV event, other management strategies that do NOT include the use of NSAIDs should be considered first. **To minimize the potential risk for an adverse CV event, the lowest effective dose should be used for the shortest possible duration.**

Endocrine and Metabolism

Corticosteroids: PEDIAPHARM NAPROXEN SUSPENSION (naproxen) is NOT a substitute for corticosteroids. It does NOT treat corticosteroid insufficiency. Abrupt discontinuation of corticosteroids may lead to exacerbation of corticosteroid-responsive illness. Patients on prolonged corticosteroid therapy should have their therapy tapered slowly if a decision is made to discontinue corticosteroids. (see DRUG INTERACTIONS: Drug-Drug Interactions, Glucocorticoids)

Gastrointestinal

Serious GI toxicity (sometimes fatal), such as ulceration, inflammation, gastrointestinal bleeding, perforation and obstruction of the upper and lower gastrointestinal tract, can occur at any time, with or without warning symptoms, in patients treated with NSAIDs, such as PEDIAPHARM NAPROXEN SUSPENSION. Minor upper GI problems, such as dyspepsia, commonly occur at any time. Health care providers should remain alert for ulceration and bleeding in patients treated with PEDIAPHARM NAPROXEN SUSPENSION, even in the absence of previous GI tract symptoms. Most spontaneous reports of fatal GI events are in elderly or debilitated patients and therefore special care should be taken in treating this population. **To minimize the potential risk for an adverse GI event, the lowest effective dose should be used for the shortest possible duration.** For high risk patients, alternate therapies that do not involve NSAIDs should be considered. (see WARNINGS AND PRECAUTIONS: Special Populations, Geriatrics)

Patients should be informed about the signs and/or symptoms of serious GI toxicity and instructed to discontinue using PEDIAPHARM NAPROXEN SUSPENSION and seek emergency medical attention if they experience any such symptoms. The utility of periodic laboratory monitoring has NOT been demonstrated, nor has it been adequately assessed. Most patients who develop a serious upper GI adverse event on NSAID therapy have no symptoms. Upper GI ulcers, gross bleeding or perforation, caused by NSAIDs, appear to occur in approximately 1% of patients treated for 3-6 months, and in about 2-4% of patients treated for one year. These trends continue, thus increasing the likelihood of developing a serious GI event at some time during the course of therapy. Even short-term therapy has its risks.

Caution should be taken if prescribing PEDIAPHARM NAPROXEN SUSPENSION to patients with a prior history of peptic / duodenal ulcer disease or gastrointestinal bleeding as these individuals have a greater than 10-fold higher risk for developing a GI bleed when taking a NSAID than patients with neither of these risk factors. Other risk factors for GI ulceration and

bleeding include the following: *Helicobacter pylori* infection, increased age, prolonged use of NSAID therapy, excess alcohol intake, smoking, poor general health status or concomitant therapy with any of the following:

- Anti-coagulants (e.g. warfarin)
- Anti-platelet agents (e.g. ASA, clopidogrel)
- Oral corticosteroids (e.g. prednisone)
- Selective Serotonin Reuptake Inhibitors (SSRIs) (e.g. citalopram, fluoxetine, paroxetine, sertraline)

Genitourinary

Some NSAIDs are associated with persistent urinary symptoms (bladder pain, dysuria, urinary frequency), hematuria or cystitis. The onset of these symptoms may occur at any time after the initiation of therapy with a NSAID. Should urinary symptoms occur, in the absence of an alternate explanation, treatment with PEDIAPHARM NAPROXEN SUSPENSION should be stopped to ascertain if symptoms disappear. This should be done before urological investigations or treatments are carried out.

Hematologic

NSAIDs inhibiting prostaglandin biosynthesis interfere with platelet function to varying degrees; patients who may be adversely affected by such an action, such as those on anti-coagulants or suffering from haemophilia or platelet disorders should be carefully observed when PEDIAPHARM NAPROXEN SUSPENSION is administered.

Anti-coagulants: Numerous studies have shown that the concomitant use of NSAIDs and anticoagulants increases the risk of bleeding. Concurrent therapy of PEDIAPHARM NAPROXEN SUSPENSION with warfarin requires close monitoring of the international normalized ratio (INR).

Even with therapeutic INR monitoring, increased bleeding may occur.

Anti-platelet Effects: NSAIDs inhibit platelet aggregation and have been shown to prolong bleeding time in some patients. Unlike acetylsalicylic acid (ASA), their effect on platelet function is quantitatively less, or of shorter duration, and is reversible.

PEDIAPHARM NAPROXEN SUSPENSION and other NSAIDs have no proven efficacy as anti-platelet agents and should NOT be used as a substitute for ASA or other anti-platelet agents for prophylaxis of cardiovascular thromboembolic diseases. Anti-platelet therapies (e.g. ASA) should NOT be discontinued. There is some evidence that use of NSAIDs with ASA can markedly attenuate the cardioprotective effects of ASA. (see DRUG INTERACTIONS: Drug-Drug Interactions, Acetylsalicylic Acid or other NSAIDs)

Concomitant administration of PEDIAPHARM NAPROXEN SUSPENSION with low dose ASA increases the risk of GI ulceration and associated complications.

Blood dyscrasias: Blood dyscrasias (such as neutropenia, leukopenia, thrombocytopenia, aplastic anemia and agranulocytosis) associated with the use of NSAIDs are rare, but could occur with severe consequences.

Anemia is sometimes seen in patients receiving NSAIDs, including PEDIAPHARM NAPROXEN SUSPENSION. This may be due to fluid retention, GI blood loss, or an incompletely described effect upon erythropoiesis. Patients on long-term treatment with NSAIDs, including PEDIAPHARM NAPROXEN SUSPENSION, should have their hemoglobin or hematocrit checked if they exhibit any signs or symptoms of anemia or blood loss.

Hepatic/Biliary/Pancreatic

As with other NSAIDs, borderline elevations of one or more liver enzyme tests (AST, ALT, alkaline phosphatase) may occur in up to 15% of patients. These abnormalities may progress, may remain essentially unchanged, or may be transient with continued therapy.

Chronic alcoholic liver disease and probably also other forms of cirrhosis reduce the total plasma concentration of naproxen, but the plasma concentration of unbound naproxen is increased. The implication of this finding for naproxen dosing is unknown, but caution is advised when high doses are required. It is prudent to use the lowest effective dose.

A patient with symptoms and/or signs suggesting liver dysfunction, or in whom an abnormal liver function test has occurred, should be evaluated for evidence of the development of a more severe hepatic reaction while on therapy with this drug. Severe hepatic reactions including jaundice and cases of fatal hepatitis, liver necrosis and hepatic failure, some of them with fatal outcomes, have been reported with NSAIDs.

Although such reactions are rare, if abnormal liver tests persist or worsen, if clinical signs and symptoms consistent with liver disease develop (e.g. jaundice), or if systemic manifestations occur (e.g. eosinophilia, associated with rash, etc.), this drug should be discontinued.

If there is a need to prescribe this drug in the presence of impaired liver function, it must be done under strict observation.

Hypersensitivity Reactions:

Anaphylactoid Reactions: As with NSAIDs in general, anaphylactoid reactions have occurred in patients without known prior exposure to PEDIAPHARM NAPROXEN SUSPENSION. In post-marketing experience, rare cases of anaphylactic/ anaphylactoid reactions and angioedema have been reported in patients receiving PEDIAPHARM NAPROXEN SUSPENSION.

PEDIAPHARM NAPROXEN SUSPENSION should NOT be given to patients with the ASA-triad. This symptom complex typically occurs in asthmatic patients who experience rhinitis with or without nasal polyps, or who exhibit severe, potentially fatal bronchospasm after taking ASA or other NSAIDs (see CONTRAINDICATIONS).

ASA-Intolerance: PEDIAPHARM NAPROXEN SUSPENSION should NOT be given to patients with complete or partial syndrome of ASA-intolerance (rhinosinusitis, urticaria/angioedema, nasal polyps, asthma) in whom asthma, anaphylaxis, urticaria/angioedema, rhinitis or other allergic manifestations are precipitated by ASA or other NSAIDs. Fatal anaphylactoid reactions have occurred in such individuals. As well, individuals with the above medical problems are at risk of a severe reaction even if they have taken NSAIDs in the past without any adverse reaction (see CONTRAINDICATIONS).

Cross-sensitivity: Patients sensitive to one NSAID may be sensitive to any of the other NSAIDs as well.

Serious skin reactions: (See WARNINGS AND PRECAUTIONS: Skin)

Immune

(See WARNINGS AND PRECAUTIONS: Infection, Aseptic Meningitis)

Infection

PEDIAPHARM NAPROXEN SUSPENSION, in common with other NSAIDs, may mask signs and symptoms of an underlying infectious disease.

Aseptic Meningitis: Rarely, with some NSAIDs, the symptoms of aseptic meningitis (stiff neck, severe headaches, nausea and vomiting, fever or clouding of consciousness) have been observed. Patients with autoimmune disorders (systemic lupus erythematosus, mixed connective tissue diseases, etc.) seem to be pre-disposed. Therefore, in such patients, the health care provider must be vigilant to the development of this complication.

Neurologic

Some patients may experience drowsiness, dizziness, blurred vision, vertigo, tinnitus, hearing loss, insomnia or depression with the use of NSAIDs, such as PEDIAPHARM NAPROXEN SUSPENSION. If patients experience such adverse reaction(s), they should exercise caution in carrying out activities that require alertness.

Ophthalmologic

Blurred and/or diminished vision has been reported with the use of NSAIDs. If such symptoms develop PEDIAPHARM NAPROXEN SUSPENSION should be discontinued and an ophthalmologic examination performed. Ophthalmologic examination should be carried out at periodic intervals in any patient receiving PEDIAPHARM NAPROXEN SUSPENSION for an extended period of time.

Peri-Operative Considerations

(See CONTRAINDICATIONS: Coronary Artery Bypass Graft Surgery)

Psychiatric

(See WARNINGS AND PRECAUTIONS: Neurologic)

Renal

Long term administration of NSAIDs to animals has resulted in renal papillary necrosis and other abnormal renal pathology. In humans, there have been reports of acute interstitial nephritis, hematuria, low grade proteinuria and occasionally nephrotic syndrome.

Renal insufficiency due to NSAID use is seen in patients with pre-renal conditions leading to reduction in renal blood flow or blood volume. Under these circumstances, renal prostaglandins help maintain renal perfusion and glomerular filtration rate (GFR). In these patients, administration of a NSAID may cause a reduction in prostaglandin synthesis leading to impaired renal function. Patients at greatest risk of this reaction are those with pre-existing renal insufficiency (GFR < 60 mL/min or 1 mL/s), dehydrated patients, patients on salt restricted diets, those with congestive heart failure, cirrhosis, liver dysfunction, taking angiotensin-converting enzyme inhibitors, angiotensin receptor blockers, cyclosporin, diuretics, and those who are elderly. Serious or life-threatening renal failure has been reported in patients with normal or impaired renal function after short term therapy with NSAIDs. Even patients at risk who demonstrate the ability to tolerate a NSAID under stable conditions may decompensate during periods of added stress (e.g. dehydration due to gastroenteritis). Discontinuation of NSAIDs is usually followed by recovery to the pre-treatment state.

Caution should be used when initiating treatment with NSAIDs, such as PEDIAPHARM NAPROXEN SUSPENSION, in patients with considerable dehydration. Such patients should be rehydrated prior to initiation of therapy. Caution is also recommended in patients with pre-existing kidney disease.

Advanced Renal Disease: (See CONTRAINDICATIONS)

Fluid and Electrolyte Balance: Use of NSAIDs, such as PEDIAPHARM NAPROXEN SUSPENSION, can promote sodium retention in a dose-dependent manner, which can lead to fluid retention and edema, and consequences of increased blood pressure and exacerbation of congestive heart failure. Thus, caution should be exercised in prescribing PEDIAPHARM NAPROXEN SUSPENSION in patients with a history of congestive heart failure, compromised cardiac function, hypertension, increased age or other conditions predisposing to fluid retention (see WARNINGS AND PRECAUTIONS: Cardiovascular).

Use of NSAIDs, such as PEDIAPHARM NAPROXEN SUSPENSION, can increase the risk of hyperkalemia, especially in patients with diabetes mellitus, renal failure, increased age, or those receiving concomitant therapy with adrenergic blockers, angiotensin-converting enzyme inhibitors, angiotensin-II receptor antagonists, cyclosporin, or some diuretics.

Electrolytes should be monitored periodically (see CONTRAINDICATIONS).

Naproxen formulated as a suspension (25 mg/mL) contains sodium chloride (20 mg/mL). This should be considered in patients whose overall intake of sodium must be restricted.

Respiratory

ASA-induced asthma is an uncommon but very important indication of ASA and NSAID sensitivity. It occurs more frequently in patients with asthma who have nasal polyps.

Sexual Function/Reproduction

The use of PEDIAPHARM NAPROXEN SUSPENSION, as with any drug known to inhibit cyclooxygenase/ prostaglandin synthesis, may impair fertility and is not recommended in women attempting to conceive. Therefore, in women who have difficulties conceiving, or who are undergoing investigation of infertility, withdrawal of PEDIAPHARM NAPROXEN SUSPENSION should be considered.

Skin

In rare cases, serious skin reactions such as Stevens-Johnson syndrome, toxic epidermal necrolysis, exfoliative dermatitis and erythema multiforme have been associated with the use of some NSAIDs. Because the rate of these reactions is low, they have usually been noted during post-marketing surveillance in patients taking other medications also associated with the potential development of these serious skin reactions. Thus, causality is NOT clear. These reactions are potentially life threatening but may be reversible if the causative agent is discontinued and appropriate treatment instituted. Patients should be advised that if they experience a skin rash they should discontinue their NSAID and contact their physician for assessment and advice, including which additional therapies to discontinue.

Special Populations

Pregnant Women: PEDIAPHARM NAPROXEN SUSPENSION is CONTRAINDICATED for use during the third trimester of pregnancy because of risk of premature closure of the ductus arteriosus and the potential to prolong parturition (see TOXICOLOGY).

Caution should be exercised in prescribing PEDIAPHARM NAPROXEN SUSPENSION during the first and second trimesters of pregnancy (see TOXICOLOGY).

Inhibition of prostaglandin synthesis may adversely affect pregnancy and/or the embryo-foetal development. Data from epidemiological studies suggest an increased risk of miscarriage and of cardiac malformation after use of a prostaglandin synthesis inhibitor in early pregnancy.

In animals, administration of a prostaglandin synthesis inhibitor has been shown to result in increased pre- and post-implantation loss and embryo-foetal lethality. In addition, increased incidences of various malformations, including cardiovascular, have been reported in animals given a prostaglandin synthesis inhibitor during the organogenetic period.

PEDIAPHARM NAPROXEN SUSPENSION is not recommended in labour and delivery because, through their prostaglandin synthesis inhibitory effect, they may adversely affect fetal circulation and inhibit uterine contractions, thus increasing the risk of uterine hemorrhage.

Nursing Women: (See CONTRAINDICATIONS)

Pediatrics: (See CONTRAINDICATIONS)

Geriatrics: Patients older than 65 years (referred to in this document as older or elderly) and frail or debilitated patients are more susceptible to a variety of adverse reactions from NSAIDs. The incidence of these adverse reactions increases with dose and duration of treatment. In addition, these patients are less tolerant to ulceration and bleeding. Most reports of fatal GI events are in this population. Older patients are also at risk of lower esophageal injury including ulceration and bleeding. For such patients, consideration should be given to a starting dose lower than the one usually recommended, with individual adjustment when necessary and under close supervision.

Monitoring and Laboratory Tests

Patients on long-term treatment with PEDIAPHARM NAPROXEN SUSPENSION should have their blood pressure monitored regularly and an ophthalmic examination should be carried out at periodic intervals (See WARNINGS AND PRECAUTIONS: Cardiovascular and Ophthalmic).

Hemoglobin, hematocrit, red blood cells (RBCs), white blood cells (WBCs), and platelets should be checked in patients on long-term treatment with PEDIAPHARM NAPROXEN SUSPENSION. Additionally, concurrent therapy with warfarin requires close monitoring of the international normalized ratio (INR) (See WARNINGS AND PRECAUTIONS: Hematology).

Serum transaminase and bilirubin should be monitored regularly during PEDIAPHARM NAPROXEN SUSPENSION therapy (see WARNINGS AND PRECAUTIONS: Hepatic, Biliary, Pancreatic).

Serum creatinine, creatine clearance and serum urea should be checked in patient during PEDIAPHARM NAPROXEN SUSPENSION therapy. Electrolytes including serum potassium should be monitored periodically (see WARNINGS AND PRECAUTIONS: Renal).

Monitoring of plasma lithium concentration is recommended when stopping or starting PEDIAPHARM NAPROXEN SUSPENSION therapy.

ADVERSE REACTIONS

Adverse Drug Reaction Overview

The most common adverse reactions encountered with nonsteroidal anti-inflammatory drugs are gastrointestinal, of which peptic ulcer, with or without bleeding, is the most severe. Fatalities have occurred particularly in the elderly.

As with all drugs in this class, the frequency and severity of adverse events depends on several factors: the dose of the drug and duration of treatment; the age, the sex, physical condition of the patient; any concurrent medical diagnoses or individual risk factors.

Clinical Trial Adverse Drug Reactions

Because clinical trials are conducted under very specific conditions the adverse reaction rates observed in the clinical trials may not reflect the rates observed in practice and should not be compared to the rates in the clinical trials of another drug. Adverse drug reaction information from clinical trials is useful for identifying drug-related adverse events and for approximating rates.

A clinical study found gastrointestinal reactions to be more frequent and more severe in rheumatoid arthritis patients taking daily doses of 1500 mg naproxen compared to those taking 750 mg naproxen.

Adverse reactions identified in controlled clinical trials in 960 patients with rheumatoid arthritis or osteoarthritis treated with naproxen, as standard tablets, are listed below. PEDIAPHARM NAPROXEN SUSPENSION was found to have similar bioavailability to the naproxen tablets.

Table 1: Most Common Clinical Trial Adverse Drug Reactions (3%-9% and 1%-3%)

Body System	Incidence	Adverse Reaction
Gastrointestinal	3%-9%	Heartburn, constipation, abdominal pain, nausea
	1%-3%	Diarrhea, dyspepsia, stomatitis, diverticulitis, gastrointestinal bleeding
Central Nervous System	3%-9%	Headache, dizziness, drowsiness
	1%-3%	Light-headedness, vertigo, depression, fatigue. Occasionally patients had to discontinue treatment because of the severity of some of these complaints (headache and dizziness).
Dermatologic	3%-9%	Pruritus, ecchymoses, skin eruptions
	1%-3%	Sweating, purpura
Cardiovascular	3%-9%	Dyspnea, peripheral edema
	1%-3%	Palpitations
Special Senses	3%-9%	Tinnitus
	1%-3%	Hearing disturbances
General	1%-3%	Thirst

Less Common Clinical Trial Adverse Drug Reactions (<1%)

Gastrointestinal	gastrointestinal bleeding, hematemesis, melena, peptic ulceration with or without bleeding and/or perforation, vomiting, ulcerative stomatitis.
Central Nervous System	inability to concentrate, malaise, myalgia, insomnia and cognitive dysfunction (i.e. decreased attention span, loss of short-term memory, difficulty with calculations).
Dermatologic	alopecia, urticaria, skin rash, erythema multiforme, Stevens-Johnson syndrome, epidermal necrolysis, photosensitive dermatitis, exfoliative dermatitis, erythema nodosum.
Hepatic	Abnormal liver function tests, jaundice, cholestasis and hepatitis.
Cardiovascular	congestive heart failure and vasculitis.
Renal	Glomerular nephritis, hematuria, interstitial nephritis, nephrotic syndrome, nephropathy and tubular necrosis.
Hematologic	Eosinophilia, granulocytopenia, leukopenia, thrombocytopenia, agranulocytosis, aplastic anemia and hemolytic anemia.
Special Senses	hearing impairment and visual disturbances.
Reproductive, female	infertility
General	muscle weakness, anaphylactoid reactions, menstrual disorders, pyrexia (chills and fever), angioneurotic edema, hyperglycemia, hypoglycemia and eosinophilic pneumonitis.

Post-Market Adverse Drug Reactions

The following additional adverse events have been reported with NSAIDs including naproxen and naproxen sodium:

Gastrointestinal:	Inflammation, bleeding (sometimes fatal, particularly in the elderly), ulceration, perforation and obstruction of the upper or lower gastrointestinal tract. Oesophagitis, gastritis, pancreatitis, stomatitis. Exacerbation of ulcerative colitis and Crohn's disease. Heartburn, dyspepsia, abdominal pain, nausea, vomiting, diarrhoea, flatulence, constipation, haematemesis, melaena.
Infections:	aseptic meningitis
Blood and Lymphatic System Disorders:	agranulocytosis, aplastic anaemia, eosinophilia, haemolytic anaemia, leucopenia, thrombocytopenia
Immune System Disorders:	anaphylactoid reactions
Metabolic and Nutrition Disorders:	hyperkalemia
Psychiatric Disorders:	depression, dream abnormalities, insomnia
Nervous System	dizziness, drowsiness, headache, lightheadedness, retrobulbar

Disorders:	optic neuritis convulsions, cognitive dysfunction, inability to concentrate
Eye Disorders:	visual disturbances, corneal opacity, papillitis, papilloedema
Ear and Labyrinth Disorders:	hearing impairment, hearing disturbances, tinnitus, vertigo
Cardiac Disorders:	palpitations, cardiac failure has been reported in association with NSAID treatment, congestive heart failure
Vascular Disorders:	hypertension, vasculitis

Clinical trial and epidemiological data suggest that use of coxibs and some NSAIDs (particularly at high doses and in long term treatment) may be associated with a small increased risk of arterial thrombotic events (for example myocardial infarction or stroke).

Respiratory, Thoracic and Mediastinal Disorders:	dyspnoea, pulmonary oedema, asthma, eosinophilic pneumonitis.
Hepatobiliary Disorders:	hepatitis (some cases of hepatitis have been fatal), jaundice.
Skin and Subcutaneous Tissue Disorders:	ecchymoses, itching (pruritus), purpura, skin eruptions, sweating, alopecia, epidermal necrolysis, very rarely toxic epidermal necrolysis, erythema multiforme, bullous reactions, including Stevens-Johnson syndrome, erythema nodosum, fixed drug eruption, lichen planus, pustular reaction, skin rashes, SLE, urticaria, photosensitivity reactions, including rare cases resembling porphyria cutanea tarda (“pseudoporphyria”) or epidermolysis bullosa and angioneurotic oedema.

If skin fragility, blistering or other symptoms suggestive of pseudoporphyria occur, treatment should be discontinued and the patient monitored.

Musculoskeletal and Connective Tissue Disorders:	myalgia, muscle weakness.
Renal and Urinary Disorders:	haematuria, interstitial nephritis, nephrotic syndrome, renal disease, renal failure, renal papillary necrosis
Reproductive System and Breast Disorders:	female infertility

General Disorders and Administration Site Conditions: oedema, thirst, pyrexia (chills and fever), malaise

Investigations: abnormal liver function tests, raised serum creatinine

DRUG INTERACTIONS

Drug-Drug Interactions

Acetylsalicylic acid (ASA) or other NSAIDs: The use of PEDIAPHARM NAPROXEN SUSPENSION in addition to any other NSAID, including over-the-counter ones (such as ASA and ibuprofen) for analgesic and/or anti-inflammatory effects is NOT recommended because of the absence of any evidence demonstrating synergistic benefits and the potential for additive adverse reactions.

The exception is the use of low dose ASA for cardiovascular protection, when another NSAID is being used for its analgesic/anti-inflammatory effect, keeping in mind that combination NSAID therapy is associated with additive adverse reactions.

Some NSAIDs (e.g. ibuprofen) may interfere with the anti-platelet effects of low dose ASA, possibly by competing with ASA for access to the active site of cyclooxygenase-1.

Albumin Bound Drugs: The naproxen anion may displace from their binding sites other drugs which are also albumin-bound and may lead to drug interactions. For example, in patients receiving bishydroxycoumarin or warfarin, the addition of PEDIAPHARM NAPROXEN SUSPENSION could prolong the prothrombin time. These patients should, therefore, be under careful observation. Similarly, patients receiving PEDIAPHARM NAPROXEN SUSPENSION and a hydantoin, sulfonamide or sulfonyleurea should be observed for adjustment of dose if required.

Antacids: The rate of absorption of naproxen is altered by concomitant administration of antacids but is not adversely influenced by the presence of food.

Anti-coagulants: (See WARNINGS AND PRECAUTIONS: Hematologic, Anticoagulants)

Anti-hypertensives: NSAIDs may diminish the anti-hypertensive effect of angiotensin converting enzyme (ACE) inhibitors and angiotensin receptor blockers (ARBs).

Concomitant use of NSAIDs with ACE inhibitors or angiotensin receptor blockers may increase the risk of renal dysfunction, especially in patients with pre-existing poor renal function (see WARNINGS AND PRECAUTIONS: Renal).

Combinations of ACE inhibitors, angiotensin-II antagonists, or diuretics with NSAIDs might have an increased risk for acute renal failure and hyperkalemia. Blood pressure and renal function (including electrolytes) should be monitored more closely in this situation, as occasionally there can be a substantial increase in blood pressure.

Naproxen and other non-steroidal anti-inflammatory drugs can reduce the antihypertensive effect of propranolol and other beta blockers as well as other antihypertensive agents.

Anti-platelet Agents (including ASA): There is an increased risk of bleeding, via inhibition of platelet function, when anti-platelet agents are combined with NSAIDs, such as PEDIAPHARM NAPROXEN SUSPENSION. (see WARNINGS AND PRECAUTIONS: Hematologic, Anti-platelet Effects)

Cholestyramine

Concomitant administration of cholestyramine can delay the absorption of naproxen, but does not affect its extent.

Cyclosporin: Inhibition of renal prostaglandin activity by NSAIDs may increase the plasma concentration of cyclosporine and/or the risk of cyclosporine induced nephrotoxicity. Patients should be carefully monitored during concurrent use.

Digoxin: Concomitant administration of an NSAID with digoxin can result in an increase in digoxin concentrations which may result in digitalis toxicity. Increased monitoring and dosage adjustments of digitalis glycosides may be necessary during and following concurrent NSAID therapy.

Diuretics: Clinical studies as well as post-marketing observations have shown that NSAIDs can reduce the effect of diuretics.

Glucocorticoids: Some studies have shown that the concomitant use of NSAIDs and oral glucocorticoids increases the risk of GI adverse events such as ulceration and bleeding. This is especially the case in older (> 65 years of age) individuals.

Lithium: Monitoring of plasma lithium concentrations is advised when stopping or starting a NSAID, as increased lithium concentrations can occur.

Methotrexate: Caution is advised in the concomitant administration of naproxen and methotrexate since naproxen and other non-steroidal anti-inflammatory agents have been reported to reduce the tubular secretion of methotrexate in an animal model, thereby possibly enhancing its toxicity.

Probenecid:

Probenecid given concurrently increases naproxen anion plasma levels and extends its plasma half-life significantly. Caution is advised when probenecid is administered concurrently.

Selective Serotonin Reuptake Inhibitors (SSRIs): Concomitant administration of NSAIDs and SSRIs may increase the risk of gastrointestinal ulceration and bleeding (see WARNINGS AND PRECAUTIONS: Gastrointestinal).

Drug-Food Interactions

Concomitant administration of food can delay the absorption of naproxen, but does not affect its extent.

Drug-Herb Interactions

Interactions with herbal products have not been established.

Drug-Laboratory Interactions

Interactions with laboratory tests have not been established.

Drug-Lifestyle Interactions

There are no specific studies about effects on the ability to drive vehicles and to use machinery. Patients who experience visual disturbances or other central nervous system disturbances should refrain from these activities.

Concurrent use of alcohol with an NSAID may increase the risk of gastrointestinal side effects, including ulceration and hemorrhage.

DOSAGE AND ADMINISTRATION

Recommended Dose and Dosage Adjustment

Adult:

Use of PEDIAPHARM NAPROXEN SUSPENSION should be limited to the lowest effective dose for the shortest possible duration of treatment (see INDICATIONS AND CLINICAL USE). For all indications, treatment must be initiated with the lowest dose.

Osteoarthritis/Rheumatoid Arthritis/Ankylosing Spondylitis

The usual total daily oral dosage for osteoarthritis, rheumatoid arthritis and ankylosing spondylitis is 250 mg twice per day. It may be increased gradually to 375 mg or 500 mg twice per day or decreased depending on the patient's response.

Table 2: Recommended Dosage Chart: Osteoarthritis / Rheumatoid Arthritis / Ankylosing Spondylitis

	<u>Dose Frequency</u>	<u>Total Daily Dose</u>
Initial Dose: 250 mg / 10 mL	Two times per day	500 mg
Dose Adjustment: May gradually increase dose (if necessary) to: 375 mg / 15 mL	Two times per day	750 mg
OR		
500 mg / 20 mL	Two times per day	1000 mg
Dose Adjustment: Decrease dose depending on response. Use lowest effective dose.		

Studies have not shown any clinically significant benefit in using doses higher than 1000 mg/day. In patients who tolerate lower doses of naproxen well and who exhibit only a partial response to 1000 mg/day, the dose may be increased to 1500 mg/day for limited periods. The

1500 mg/kg dose has not been studied in clinical trials with PEDIAPHARM NAPROXEN SUSPENSION.

When treating such patients with naproxen 1500 mg/day, the physician should observe sufficient increased clinical benefit to offset the potential increased risk (see ADVERSE REACTIONS).

In addition, patients on 1500 mg/day need to be followed closely for the development of any adverse events.

During long-term administration the dose of PEDIAPHARM NAPROXEN SUSPENSION may be adjusted up or down depending on the clinical response of the patient. A lower dose may suffice for long-term administration.

Analgesia/Musculoskeletal Injuries

The recommended oral dose is 750 mg/day divided into either two or three doses/day. This may be increased to 1000 mg/day if needed. The lowest effective dose should be used.

Table 3: Recommended Dosage Chart: Analgesia / Musculoskeletal Injuries

	<u>Dose Frequency</u>	<u>Total Daily Dose</u>
Initial Dose:		
<u>Option 1:</u> 375 mg / 15 mL	Two times per day	750 mg
OR		
<u>Option 2:</u> 250 mg / 10 mL	Three times per day	750 mg
Dose Adjustment: May increase dose (if necessary) to: 500 mg / 20 mL	Two times per day	1000 mg
<u>Dose Adjustment: Decrease dose depending on response. Use lowest effective dose.</u>		

Dysmenorrhea

The recommended starting dose is 500 mg, followed by 250 mg every 6 - 8 hours, as required. The total daily dose should not exceed 1250 mg on the first day of use and should not exceed 1000 mg on subsequent days of use. Alternatively, a dose of 500 mg given twice daily may be used.

Table 4: Recommended Dosage Chart: Dysmenorrhea

	<u>Dose Frequency</u>	<u>Total Daily Dose</u>
<u>Option 1:</u> First dose: 500 mg / 20 mL Followed by: 250 mg / 10 mL	Once Every 6-8 hours, as required.	First day: 1000 to 1250 mg Followed by: 750 to 1000 mg
	OR	
<u>Option 2:</u> 500 mg / 20 mL	Two times per day	1000 mg

Juvenile Rheumatoid Arthritis (2-16 years):

PEDIAPHARM NAPROXEN SUSPENSION is indicated for juvenile arthritis in children 2 years or older. It allows for flexible dose titration based on the child's weight. The recommended total daily dose is approximately 10 mg/kg in two divided doses at 12 hour intervals.

Do not exceed recommended dose, dose frequency or total daily dose. Administration of PEDIAPHARM NAPROXEN SUSPENSION more frequently than twice daily is not necessary. Clinical experience has shown that steroids can often be decreased and sometimes eliminated when PEDIAPHARM NAPROXEN SUSPENSION is administered.

The following dosing chart may be used as a guide:

Table 5: Recommended Dosage Chart: Juvenile Rheumatoid Arthritis

<u>Child's weight</u>	<u>Dose (Volume)*</u>	<u>Dose Frequency*</u>	<u>Total Daily Dose*</u>
13 kg	65 mg / 2.6 mL	Two times per day	130 mg
15 kg	75 mg / 3 mL	Two times per day	150 mg
20 kg	100 mg / 4 mL	Two times per day	200 mg
25 kg	125 mg / 5 mL	Two times per day	250 mg
30 kg	150 mg / 6 mL	Two times per day	300 mg
40 kg	200 mg / 8 mL	Two times per day	400 mg
50 kg	250 mg / 10 mL	Two times per day	500 mg

*** Do not exceed recommended dose, dose frequency or total daily dose.**

Administration

Patients and/or caregivers should be advised to read the PEDIAPHARM NAPROXEN SUSPENSION Dosing Instructions (PART III CONSUMER INFORMATION, Proper Use of this Medication) for complete instructions on how to properly dose and administer the PEDIAPHARM NAPROXEN SUSPENSION.

Bottles of PEDIAPHARM NAPROXEN SUSPENSION should be shaken gently before use. The provided adapter and calibrated oral dosing syringe should be used to administer the oral suspension. The adapter, which is supplied in the product carton, should be inserted firmly into the neck of the bottle before use and remain in place for the duration of the usage of the bottle. The dosing syringe should be inserted into the adapter and the dose withdrawn from the inverted bottle. The cap should be replaced after each use. The cap fits properly when the adapter is in place.

Missed Dose

The missed dose should be taken as soon as remembered, and then the regular dosing schedule should be continued. Two doses of PEDIAPHARM NAPROXEN SUSPENSION should not be taken at the same time.

OVERDOSAGE

For management of a suspected drug overdose, contact your regional Poison Control Centre.

Symptoms and Signs

Significant overdose may be characterized by drowsiness, dizziness, disorientation, heartburn, indigestion, epigastric pain, abdominal discomfort, nausea, vomiting, transient alterations in liver function, hypoprothrombinemia, renal dysfunction, metabolic acidosis and apnea. A few patients have experienced convulsions, but it is not clear whether or not these were naproxen related.

Gastrointestinal bleeding may occur. Hypertension, acute renal failure, respiratory depression and coma may occur after the ingestion of NSAIDs but are rare.

Anaphylactoid reactions have been repeated with therapeutic ingestion of NSAIDs, and may occur following an overdose.

Treatment

Patients should be managed by symptomatic and supportive care following NSAIDs overdose. There are no specific antidotes. Prevention of further absorption (e.g. activated charcoal) may be indicated in patients seen within 4 hours of ingestion with symptoms or following a large overdose. Forced diuresis, alkalinization of urine, haemodialysis, or haemoperfusion may not be useful due to high protein binding.

ACTION AND CLINICAL PHARMACOLOGY

Mechanism of Action

PEDIAPHARM NAPROXEN SUSPENSION contains naproxen, a member of the arylacetic acid group of NSAIDs.

Naproxen is a nonsteroidal anti-inflammatory drug (NSAID) with analgesic properties. The mechanism of action of naproxen, like that of other NSAIDs, is not completely understood but may be related to prostaglandin synthetase inhibition.

Pharmacodynamics

(See DETAILED PHARMACOLOGY)

Pharmacokinetics

Naproxen is rapidly and completely absorbed from the gastro-intestinal tract. After oral administration of naproxen, peak plasma levels of naproxen anion are attained in 2 to 4 hours, with steady state conditions normally achieved after 4-5 doses. Plasma naproxen levels and areas under plasma concentration vs. time curves increased linearly with dose increments up to 500 mg twice a day, but larger doses resulted in a plateau effect. The mean biological half-life of the anion in humans is approximately 13 hours, and at therapeutic levels it is greater than 99% albumin bound. Approximately 95% of the dose is excreted in the urine, primarily as naproxen, 6-0-desmethyl naproxen or their conjugates. The rate of excretion has been found to coincide closely with the rate of drug disappearance from the plasma. The drug does not induce metabolizing enzymes.

In children with rheumatic diseases aged between 5 to 16 years, naproxen reached peak plasma levels 2 to 4 hours following oral dosing and the mean plasma half-life was 11.5 to 14.1 hours. PEDIAPHARM NAPROXEN SUSPENSION was found to have similar bioavailability to the naproxen tablets in two single dose studies done in 24 healthy male volunteers. No clinically significant differences in tolerance were reported between the two dosage forms.

The average maximum plasma concentration (C_{max}) following the 375 mg and 500 mg standard immediate release tablets were 46.6 and 63.1 $\mu\text{g/mL}$, respectively. The T_{max} 's were 2.3 and 2.6 hr., respectively. At steady state (multiple dosing), fluctuation in plasma levels for C_{ave} was 85.3%. Concomitant administration of food can delay the absorption of naproxen, but does not affect its extent.

STORAGE AND STABILITY

PEDIAPHARM NAPROXEN SUSPENSION: Store at room temperature not exceeding 25°C, with protection from light. Store upright.

Keep out of reach of children.

DOSAGE FORMS, COMPOSITION AND PACKAGING

PEDIAPHARM NAPROXEN SUSPENSION is available as an oral suspension. Each 5 mL contains 125 mg of naproxen. Available in bottles of 474 mL.

PEDIAPHARM NAPROXEN SUSPENSION (naproxen) 25 mg/mL also contains magnesium aluminum silicate, fumaric acid, methylparaben, sucrose, sorbitol solution, sodium chloride, imitation pineapple flavour and imitation orange flavour as inactive ingredients and F D & C Yellow #6 as colourant.

PART II: SCIENTIFIC INFORMATION

PHARMACEUTICAL INFORMATION

Drug Substance

Proper name: Naproxen

Chemical name: (+) 6 methoxy alpha methyl 2 naphthaleneacetic acid

Molecular formula and molecular mass: $C_{14}H_{14}O_3$; 230.27

Structural formula:

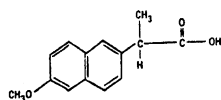

Physicochemical properties: Naproxen is an odorless white crystalline powder with a melting point of 152 – 158°C. It is highly lipid soluble, sparingly soluble in water at low pH and highly soluble in water at high pH.

CLINICAL TRIALS

No data available.

DETAILED PHARMACOLOGY

Naproxen has been shown to possess anti-inflammatory and analgesic activity as assessed by a variety of animal test procedures.

Anti-inflammatory activity: In the rat paw edema assay, naproxen was more potent than phenylbutazone and acetylsalicylic acid, and slightly less potent than indomethacin.

In the rat granuloma assay, naproxen was more active than phenylbutazone and less active than indomethacin.

Analgesic activity: In a mouse analgesic assay using phenylquinone for pain induction, naproxen was more active than phenylbutazone and acetylsalicylic acid, and less active than indomethacin. Parallel comparative analgesic studies were done in rats with yeast induced paw edema.

In these assays, naproxen had a higher relative potency than phenylbutazone and acetylsalicylic acid, but lower relative potency when compared to indomethacin.

The comparative absorption, distribution, metabolism and excretion of naproxen was studied in several species, including man. Naproxen was found to be rapidly absorbed in all species and, once in the blood was eliminated with half-lives ranging from 2 to 35 hours. Estimated volumes of distribution indicated that a large fraction of the drug is held in the blood, much like salicylates are. Virtually all of the drug present in the blood of humans was determined to be unchanged naproxen, while the rat and the monkey showed minor amounts of transformation products. With the exception of the dog, all species excreted naproxen and its metabolic transformation products predominantly in the urine. In the dog the preferred route was fecal.

Studies by Tomlinson, et al have shown that naproxen can inhibit the synthesis of prostaglandin E2 from arachidonic acid by bovine seminal vesicle microsomes. Naproxen therefore appears to act at least in part in a manner similar to other anti-inflammatory agents which block prostaglandin biosynthesis.

Human metabolic studies:

The plasma level response to oral naproxen doses ranging up to 900 mg twice daily was studied in normal subjects. Experiments with tritium labelled naproxen showed that there was no difference in the fraction of ingested drug excreted in the stools whether the dose was 250 mg or 900 mg, thus eliminating the possibility that this effect was a result of incomplete absorption. Accelerated renal clearance at high doses because of disproportionate increases in the amount of unbound drug appeared to be the most likely explanation for the plateau effect.

In patients treated with maintenance dialysis for terminal renal failure, serum level studies indicated that the metabolite 6-O-desmethyl naproxen is dialysed, whilst naproxen is not. No accumulation of naproxen was found although serum levels of the metabolite increased.

TOXICOLOGY

Acute Animal Toxicity

The oral LD₅₀ values for naproxen are as follows:

Hamster	4110 mg/kg
Rats	543 mg/kg
Dogs	>1000 mg/kg
Mice	1234 mg/kg

Subacute and Chronic Oral Toxicity

In subacute and chronic oral studies with naproxen in a variety of species, the principal pathologic effect was gastrointestinal irritation and ulceration. The lesions seen were predominantly in the small intestine and ranged from hyperemia to perforation and peritonitis.

Nephropathy was seen occasionally in rats, mice and rabbits at high dose levels of naproxen, but not in rhesus monkeys or miniature pigs. In the affected species the pathologic changes occurred in the cortex and papilla. Some rats examined 14 days after single oral doses of 230 mg/kg or more of naproxen evidenced necrotic areas of cortical and papillary tissue. Tubular dilation (ectasia) occurred in rabbits dosed orally for 14 days with 200 mg/kg/day or more of naproxen. An examination of unfixed renal tissue from rabbits so treated was conducted and revealed the presence of diffraction patterns similar to that of crystalline naproxen. This suggests that the ectasia observed was physical response to deposition of excreted naproxen within the tubules.

In mice given oral doses of 120 mg/kg/day or more of naproxen for 6 months, the kidneys were characterized by a low but non dosage related incidence of cortical sclerosis and papillary tip necrosis. Chronic administration of high doses of naproxen to mice appears to be associated with exacerbation of spontaneous murine nephropathy.

A wide variation in susceptibility to gastrointestinal lesions from administration of naproxen was evident in the various species tested. For example, 30 mg/kg/day was tolerated well by rats for 90 days, but the same dose was ulcerogenic when administered for 6 months. Rhesus monkeys and miniature swine exhibited no significant pathology when dosed with naproxen at 45 mg/kg/day for 30 days. This dose of naproxen was also tolerated by miniature swine without obvious evidence of adverse effects when administered daily for 1 year. In rhesus monkeys doses as high as 120 mg/kg/day administered b.i.d. for 6 months produced no clinical or histopathological evidence of gastrointestinal irritation although occult blood in the feces occurred more frequently in these animals as compared to controls. In rabbits the maximum tolerated repeated oral dose is 200 mg/kg/day. Mice tolerated oral daily doses of 240 mg/kg/day for 6 months. In both rabbits and mice, gastrointestinal and renal toxicity was reported at these dose levels. In dogs, on the other hand, 5.0 mg/kg/day approaches the maximum tolerated dose. This peculiar canine susceptibility to gastrointestinal effects of non-steroidal anti-inflammatory agents has also been shown with indomethacin and ibuprofen.

In dogs, naproxen exhibits a considerably longer plasma half-life than it does in rats, guinea pigs, miniature swine, monkeys and man. The same observation has been made with ibuprofen in dogs compared to rats and man. In addition, in the species listed, only the dog excretes significant amounts of administered naproxen in the feces (50%). In the rat, guinea pigs, miniature swine, monkeys and man, 86-94% of the administered drug is excreted in the urine. The suggested enterohepatic circulation of naproxen in the dog (as judged by the fecal excretion) may be a major factor in the susceptibility of the dog to gastrointestinal irritation by this compound.

Pathologic changes in the spleen and mesenteric lymph nodes as well as peritoneal inflammation and adhesions were considered to be clearly secondary to the effects of high doses of naproxen on the gastrointestinal tract. Moderate weight loss of the male secondary sex glands occurred in some studies in naproxen treated rats and dogs. Histopathologically the affected glands in some instances exhibited atrophic and/or hypoplastic changes characterized by decreased secretory material. A possible estrogenic action of naproxen as a causative factor seems highly unlikely since in standard bioassay procedures the drug exhibited no estrogenic activity. Nevertheless, daily doses of naproxen as high as 30 mg/kg administered for 60 days before mating had no effect on fertility and reproductive performance of male rats. These results reflect the physiological integrity of the entire male reproductive apparatus after administration of naproxen throughout the spermatogenic cycle.

Effect on Induced Infections in Rabbits

To determine whether treatment with naproxen affects the ability of animals to respond to bacterial infection, rabbits were inoculated subcutaneously with *Diplococcus pneumoniae*. For 21 days before bacterial challenge and during a 2-week post-challenge period, the animals were dosed daily by gavage with 2, 10 or 20 mg/kg of naproxen. Clinical condition, morbidity, mortality, gross and histopathologic changes were evaluated. There were no apparent effects of naproxen in altering the response of the animals to bacterial challenge.

Teratology

In teratology studies, no skeletal or visceral anomalies or pathologic changes were induced in the fetuses of pregnant rats and rabbits treated during organogenesis with daily oral doses of naproxen up to 20 mg/kg. In these studies there were also no significant differences from controls in the number of live fetuses, resorptions, fetal weights or ano-genital distances.

Reproductive Studies

Daily oral administration of 15, 30 or 60 mg/kg of naproxen to female rabbits from 2 weeks before mating until day 20 of pregnancy did not affect fertility, gestation or the numbers of live fetuses.

In a peri- and post-natal study in rats, oral doses of naproxen up to 20 mg/kg administered daily during the last part of pregnancy through weaning did not result in adverse effects in viability of pups, lactation index, sex ratio or weight gain of offspring. However, there was a slight increase in gestation length at the 10 and 20 mg/kg dose levels; and, at the 10 mg/kg dose level, there was a significant increase in stillbirths.

Naproxen at daily oral doses of 12, 36 or 108 mg/kg to female mice from 2 weeks before mating until weaning of the pups did not cause changes in length of gestation, number of live pups born, average pup weight at 0, 4, 7, 14 or 21 days, or sex distribution. The fertility index, gestation index and 4 day viability index were similar for mice from the control and treated groups. The 21 day survival and lactation indexes were decreased for mice from the group fed 108 mg/kg/day of naproxen but not for mice given 12 or 36 mg/kg/day. Most of this change was due to maternal mortality in the high dose group.

Recent evidence suggests that inhibition of prostaglandin synthesis by non-steroidal anti-inflammatory compounds may be related to decreased uterine contractility. Thus, the onset of labor in a rat model system can be delayed with naproxen administration without causing maternal or fetal deaths in excess of that seen in controls. Since it has been shown that Naproxen inhibits prostaglandin synthesis in vitro, it has been suggested that the effects of naproxen on uterine contractility are mediated through that mechanism.

Maternal and fetal deaths seen in naproxen treated rats were, therefore, apparently related to dystocia rather than to a direct toxic effect of the compound. Naproxen is not unique in this regard since comparable results were obtained in the rat with other commonly used non-steroidal anti-inflammatory agents.

Carcinogenicity

Naproxen was administered with food to Sprague-Dawley rats for 24 months at doses of 8, 16 and 24 mg/kg/day. Naproxen was not carcinogenic in rats.

Mutagenicity

Mutagenicity was not seen in *Salmonella typhimurium* (5 cell lines), *Sachharomyces cerevisisae* (1 cell line), and mouse lymphoma tests.

REFERENCES

1. Adams SS, Bough RG, Cliffe EE, Lessel B and Mills RFN. Absorption, distribution and toxicity of ibuprofen. *Tox Appl Pharmacol* 1969; 15:310.
2. Allen B, Edwards RI. A safety profile of controlled release naproxen tablets. Manuscript submitted to the *New Zealand Journal of Medicine* (Nov.1988).
3. Ansell BM, Hanna B, Moran H, Hall MA, Hall M and Engler C. Naproxen in juvenile chronic polyarthritis. *Eur J Rheumatol Inflamm* 1979; 2:79-83.
4. Berry H, Swinson D, Jones J and Hamilton EBD. Indomethacin and naproxen suppositories in the treatment of rheumatoid arthritis. *Ann Rheumatic Dis* 1978; 37:370-372.
5. Brogden RN, Heel RC, Speight TM and Avery GS. Naproxen up to date: a review of its pharmacological properties and therapeutic efficacy and use in rheumatic diseases and pain states. *Drugs* 1979; 18:241-277.
6. Cleland LG. Microbleeding in 28-day naproxen controlled-release (NAPROSYN SR) therapy. *Clinical Trials Journal* 1988; 25: 103-108.
7. Davis SS, Hardy JG, Wilson GC, Feeley LC, and Palin KJ. Gastrointestinal transit of a controlled release naproxen tablet formulation. *Intern J of Pharma* 1986; 32:85-90.
8. Harrison IT, Lewis B, Nelson P, Rooks WH and Roskowski AP. Non-steroidal anti-inflammatory agents I 6-substituted 2-naphthylactic acids. 1970; *J Med Chem* 13:203-205.
9. Information letter, Health Protection Branch. Nonsteroidal Anti-inflammatory Drugs. DD-33; August 21,1985.
10. Julou L, Ducrot R, Fournel J, Ganter P, Populaire P, Durel J, Myon J, Pascal S and Pasquet J. Etude toxicologique de l'acide metiazinque. *Artzn Forsch* 1969; 19:1207.
11. Laxer MR, Silverman ED, St-Cyr C, Tran MT, Lingam G. A six month open safety assessment of a naproxen suspension formulation in the therapy of juvenile rheumatoid arthritis. *Clinical Therapeutics*; 1988; 10 (4): 381-387.
12. Ling TL, Yee JP, Cohen A, Hsiao C, Gonzalez MA, Garg DC, and Weidler DJ. A multiple-dose pharmacokinetic comparison of naproxen as a once-daily controlled-release tablet and a twice-daily conventional tablet. *J Clin Pharmacol* 1987; 27:325-329.
13. Luftschain S, Bienenstock H, Varady JC and Stitt FW. Increasing dose of naproxen in rheumatoid arthritis: use with and without corticosteroids. *J Rheumatol* 1979; 6:397-404.
14. Makela AL. Naproxen in the treatment of juvenile rheumatoid arthritis. *Scan J Rheumatol* 1977; 6:193-205.

15. Makela AL and Makela P. Naproxen in the treatment of juvenile rheumatoid arthritis. Proceedings of the naproxen roundtable meeting, VIII Europ Rheumatol Congr Helsinki 1975; p 4-8.
16. McVerry, Lethbridge J, Martin N, Mukerjee SK, Littler T, Tallis R, Sibeon R, and Orme MLE. Pharmacokinetics of naproxen in elderly patients. Eur J Clin Pharmacol 1986; 31:463-468.
17. Nadell J, Bruno J, Varady J, and Segre E. Effect of naproxen and aspirin on bleeding time and platelet aggregation. J Clin Pharmacol 1974; 14(4):76-82.
18. Naproxen. Proceedings from an international medical symposium presented by Syntex Corporation. Scan J Rheumatol 1973; suppl 2.
19. Nicholls A, Hazleman B, Todd RM, Murray-Leslie C, Kuhnen H and Cain ARR. Long-term evaluation of naproxen suspension in juvenile chronic arthritis. Curr Med Res & Opin 1982; 3(3):204-207.
20. Physician's Desk Reference 1987; p 1535.
21. Rooks WH. The activity of d-2- (6'-methoxy-2"-naphthyl) -propionic acid (naproxen) versus adjuvant-induced arthritis. Fedn Proc Fedn Am Socs Exp Biol 1971; 30(2): Abst 386.
22. Roskovski AP, Rooks WH, Tomolonis AJ and Miller LM. Anti-inflammatory analgesic properties of d-2-(6'-methoxy-2'-naphthyl) propionic acid (naproxen). J Pharmac Exp Ther 1971; 179(1):114-124.
23. Runkel R, Chaplin M, Boost G, Segre E and Forchielli E. Absorption, distribution, metabolism, and excretion of naproxen in various laboratory animals and human subjects. J Pharm Sci 1972; 61(5):703-708.
24. Runkel R, Chaplin MD, Sevelius H, Ortega E and Segre E. Pharmacokinetics of naproxen overdoses. Clin Pharmacol Therp 1976; 20:269-277.
25. Runkel R, Forchielli E, Sevelius H, Chaplin M and Segre E. Non-linear plasma level response to high doses of naproxen. Clin Pharmacol Therap 1974; 15(3): 261-266.
26. Ryley NJ, and Lingam G. A pharmacokinetic comparison of controlled-release and standard naproxen tablets. Current Med Research & Opinion 1988; 11(1):10-15.
27. Canadian Multicentre Study Group. Clinical evaluation of a new controlled-release formulation of naproxen in osteoarthritis and rheumatoid arthritis. Current Med Research & Opinion 1988; 11:16-17.
28. Segre E. Long term experience with naproxen; open-label cohort survey of nearly 900 rheumatoid arthritis and osteoarthritis patients. Curr Therap Res 1980;28:47-60.
29. Syntex, (CL5850) Six-Week, Multiple-Dose Safety and Efficacy Comparison of Enteric-Coated 500-mg Naproxen and Standard 500-mg Naproxen in Arthritis Patients with NSAID Intolerance, November, 1991.

30. Tomlinson RV, Ringold HJ, Qureshi HC, Forchielli E. Relationship between inhibition of prostaglandin synthesis and drug efficacy: Support for the current therapy on mode of action of aspirin-like drugs. *Biochem Biophys Res Comm* 1972; 46(2):552-559.
31. Upton RA, Williams RL, Kelly J and Jones RM. Naproxen pharmacokinetics in the elderly. *Br J Clin Pharmac* 1984; 18:207-214.
32. Wallis WJ, and Simkin PA. Antirheumatic drug concentrations in human synovial fluid and synovial tissue - observations on extravascular pharmacokinetics. *Clin Pharmacokinetics* 1983; 8:496-522.
33. Williams RL. Naproxen disposition in patients with alcoholic cirrhosis. *Eur J Clin Pharmacol* 1984; 27:291-296.
34. Aabakken L, Ugstad M, Gamst ON, et al. Naproxen-associated gastroduodenal toxicity: enteric coated granules versus plain tablets. *Eur J Rheumatol Inflamm* 1992;12:43-8.
35. Bellamy N, Beaulieu A, Bombardier C, et al. Efficacy and tolerability of enteric-coated naproxen in the treatment of osteoarthritis and rheumatoid arthritis: a double-blind comparison with standard naproxen followed by an open-label trial. *Curr Med Res Opin* 1992;12:640-51.
36. Bellamy N, Beaulieu A, Bombardier C, et al. Open-label tolerability study of enteric-coated naproxen in the treatment of osteoarthritis and rheumatoid arthritis. *Curr Med Res Opin* 1992;12:652-61.
37. Caldwell JR, Roth SH. A double-blind study comparing the efficacy and safety of enteric coated naproxen to naproxen in the management of NSAID intolerant patients with rheumatoid arthritis and osteoarthritis. Naproxen EC Study Group. *J Rheumatol* 1994;21:689-95.
38. Henry D, Dobson A, Turner C. Variability in the risk of major gastrointestinal complications from nonaspirin nonsteroidal anti-inflammatory drugs. *Gastroenterology* 1993;105:1078-88.
39. Jung D, Schwartz KE. Steady-state pharmacokinetics of enteric-coated naproxen tablets compared with standard naproxen tablets. *Clin Ther* 1994;16:923-9.
40. Lehn OF, Jensen ON, Andersen LA, et al. Enteric-coated and plain naproxen tablets in osteoarthritis; tolerability and efficacy. *Eur J Rheumatol Inflamm* 1992;12:31-6.
41. Mehta S, Dasarathy S, Tandon RK, et al. A prospective randomized study of the injurious effects of aspirin and naproxen on the gastroduodenal mucosa in patients with rheumatoid arthritis. *Am J Gastroenterol* 1992;87:996-1000.
42. Niazi SK, Alam SM, Ahmad SI. Dose dependent pharmacokinetics of naproxen in man. *Biopharm Drug Dispos* 1996;17:355-61.
43. Simon LS, Basch CM, Young DY, et al. Effects of naproxen on renal function in older patients with mild to moderate renal dysfunction. *Br J Rheumatol* 1992;31:163-8.

44. Vree TB, van den Biggelaar-Martea M, Verwey-van Wissen CP, et al. The effects of cimetidine, ranitidine and famotidine on the single-dose pharmacokinetics of naproxen and its metabolites in humans. *Int J Clin Pharmacol Ther Toxicol* 1993;31:597-601.
45. Vree TB, van den Biggelaar-Martea M, Verwey-van Wissen CP, et al. Pharmacokinetics of naproxen, its metabolite O-desmethylnaproxen, and their acyl glucuronides in humans. *Biopharm Drug Dispos* 1993;14:491-502.
46. Wells TG, Mortensen ME, Dietrich A, et al. Comparison of the pharmacokinetics of naproxen tablets and suspension in children. *J Clin Pharmacol* 1994;34:30-3.
47. Aabakken L. NSAID-associated gastrointestinal damage: methodological considerations and a review of the experience with enteric coated naproxen. *Eur J Rheumatol Inflamm* 1992;12:9-20.
48. Gamst ON. Enteric coated naproxen tablets. *Eur J Rheumatol Inflamm* 1992;12:5-8.
49. Mowat AG. Naproxen: its current place in therapeutics. *Eur J Rheumatol Inflamm* 1992;12:1-3.
50. Todd PA, Clissold SP. Naproxen. A reappraisal of its pharmacology, and therapeutic use in rheumatic diseases and pain states. *Drugs* 1990;40:91-137.
51. G Smith et al. Reversible ovulatory failure associated with the development of luteinized unruptured follicles in women with inflammatory arthritis taking non-steroidal anti-inflammatory drugs. *British J of Rheumatology* 1996; 35: 458-462.
52. LLF Mendonca et al. Non-steriodal anti-inflammatory drugs as a possible cause for reversible infertility. *Rheumatology* 2000;39:880-882.
53. RJ Norman. Reproductive consequences of COX-2 inhibition. *The Lancet* October 20, 2001; 358:1287-1288.

PART III: CONSUMER INFORMATION**Pr PEDIAPHARM NAPROXEN SUSPENSION**
naproxen

Read this information each time you refill your prescription in case new information has been added.

This leaflet is a summary designed specifically for you to read. It will NOT tell you everything about PEDIAPHARM NAPROXEN SUSPENSION. See your health care provider and pharmacist regularly and ask them questions about your health and any medications you take.

ABOUT THIS MEDICATION**What the medication is used for:**

Your health care provider has prescribed PEDIAPHARM NAPROXEN SUSPENSION for you for one or more of the following medical conditions:

- For the treatment of the signs and symptoms of osteoarthritis, rheumatoid arthritis, ankylosing spondylitis, and juvenile rheumatoid arthritis.
- For the relief of minor aches and pains in muscles, bones and joints, mild to moderate pain accompanied by inflammation in sprains and strains and painful menstruation (primary dysmenorrhea).

What it does:

PEDIAPHARM NAPROXEN SUSPENSION (naproxen), as a nonsteroidal anti-inflammatory drug (NSAID), can reduce the chemicals produced by your body which cause pain and swelling.

PEDIAPHARM NAPROXEN SUSPENSION, as a NSAID, does NOT cure your illness or prevent it from getting worse. PEDIAPHARM NAPROXEN SUSPENSION can only relieve pain and reduce swelling as long as you continue to take it.

When it should not be used:

DO NOT TAKE PEDIAPHARM NAPROXEN SUSPENSION if you have any of the following medical conditions:

- Heart bypass surgery (planning to have or recently had)
- Severe, uncontrolled heart failure
- Bleeding in the brain or other bleeding disorders
- Current pregnancy (after 28 weeks of pregnancy)
- Currently breastfeeding (or planning to breastfeed)
- Allergy to ASA (Acetylsalicylic Acid) or other NSAIDs
- Ulcer (active)
- Bleeding from the stomach or gut (active)
- Inflammatory bowel disease (Crohn's Disease or Ulcerative Colitis)
- Liver disease (active or severe)
- Kidney disease (severe or worsening)
- High potassium in the blood

Patients who took a drug in the same class as PEDIAPHARM NAPROXEN SUSPENSION after a type of heart surgery (coronary artery bypass grafting (CABG)) were more likely to have heart attacks, strokes, blood clots in the leg(s) or lung(s), and infections or other complications than those who did NOT take that drug.

PEDIAPHARM NAPROXEN SUSPENSION should NOT be used in patients under 2 years of age since the safety and effectiveness have NOT been established.

What the medicinal ingredient is:

naproxen

What the non-medicinal ingredients are:

FD&C Yellow No. 6, fumaric acid, imitation orange flavour, imitation pineapple flavour, magnesium aluminum silicate, methylparaben, sodium chloride, sorbitol solution 70%, sucrose.

What dosage forms it comes in:

Suspension: 25 mg/mL

WARNINGS AND PRECAUTIONS

If you have, or previously had, any of the following medical conditions, see your health care provider to discuss treatment options other than PEDIAPHARM NAPROXEN SUSPENSION:

- Heart Attack or Angina
- Stroke or Mini-stroke
- Loss of Vision
- Current Pregnancy (less than 28 weeks)
- Congestive Heart Failure

Before taking this medication, tell your health care provider if you have any of the following:

- High blood pressure
- High cholesterol
- Diabetes mellitus or on a low sugar diet
- Atherosclerosis
- Poor circulation to your extremities
- Smoker or ex-smoker
- Kidney disease or urine problems
- Previous ulcer or bleeding from the stomach or gut (small or large intestine)
- Previous bleeding in the brain
- Bleeding problems
- Family history of allergy to NSAIDs, such as acetylsalicylic acid (ASA), celecoxib, diclofenac, diflunisal, etodolac, fenoprofen, flurbiprofen, ibuprofen, indomethacin, ketoprofen, ketorolac, mefenamic acid, meloxicam, nabumetone, naproxen, oxaprozin, piroxicam, rofecoxib, sulindac, tenoxicam, tiaprofenic acid, tolmetin, or valdecoxib (NOT a complete list)
- Family history of asthma, nasal polyps, long-term

swelling of the sinus (chronic sinusitis) or hives

Also, before taking this medication, tell your health care provider if you are planning to get pregnant.

While taking this medication:

- tell any other doctor, dentist, pharmacist or other health care professional that you see, that you are taking this medication, especially if you are planning to have heart surgery;
- do NOT drink alcoholic beverages while taking this medication because you would be more likely to develop stomach problems;
- fertility may be decreased. The use of PEDIAPHARM NAPROXEN SUSPENSION is not recommended in women trying to get pregnant. In women who have difficulty conceiving, stopping PEDIAPHARM NAPROXEN SUSPENSION should be considered.

INTERACTIONS WITH THIS MEDICATION

Talk to your health care provider and pharmacist if you are taking any other medication (prescription or non-prescription) such as any of the following (NOT a complete list):

- Acetylsalicylic Acid (ASA) or other NSAIDs
 - e.g. ASA, celecoxib, diclofenac, ibuprofen, indomethacin, ketorolac, meloxicam, naproxen
- Antacids
- Antidepressants
 - Selective Serotonin Reuptake Inhibitors (SSRIs)
 - e.g. citalopram, fluoxetine, paroxetine, sertraline
- Blood pressure medications
 - ACE (angiotensin converting enzyme) inhibitors
 - e.g. enalapril, lisinopril, perindopril, ramipril
 - ARBs (angiotensin II receptor blockers)
 - e.g. candesartan, irbesartan, losartan, valsartan
- Blood thinners
 - e.g. warfarin, ASA, clopidogrel
- Corticosteroids (including glucocorticoids)
 - e.g. prednisone
- Cyclosporin
- Digoxin
- Diuretics
 - e.g. furosemide, hydrochlorothiazide
- Lithium
- Methotrexate
- Oral contraceptives
- Oral hypoglycemics (diabetes medications)
- Tacrolimus

Your health care provider may prescribe low dose ASA (acetylsalicylic acid) as a blood thinner to reduce your risk of having a heart attack or stroke while you are taking

PEDIAPHARM NAPROXEN SUSPENSION. Take only the amount of ASA prescribed by your health care provider. You are more likely to upset or damage your stomach if you take both PEDIAPHARM NAPROXEN SUSPENSION and ASA than if you took PEDIAPHARM NAPROXEN SUSPENSION alone.

PROPER USE OF THIS MEDICATION

PEDIAPHARM NAPROXEN SUSPENSION is intended for use in patients older than 2 years of age for the shortest possible duration. **Do NOT use in patients under 2 years of age since safety and effectiveness have NOT been established.**

Take PEDIAPHARM NAPROXEN SUSPENSION only as directed by your health care provider. **Do NOT take more of it, do NOT take it more often and do NOT take it for a longer period of time than your health care provider recommended. If possible, you should take the lowest dose of this medication for the shortest time period.** Taking too much PEDIAPHARM NAPROXEN SUSPENSION may increase your chances of unwanted and sometimes dangerous side effects, especially if you are elderly, have other diseases or take other medications.

If you will be using PEDIAPHARM NAPROXEN SUSPENSION for more than 7 days, see your health care provider regularly to discuss whether this medicine is working for you and if it is causing you any unwanted effects.

This medication has been prescribed specifically for you. Do NOT give it to anyone else. It may harm them, even if their symptoms seem to be similar to yours.

Usual Adult Dose: 18 years or older:

Indication	Starting Dose	Dose Frequency
Osteoarthritis/ Rheumatoid Arthritis/ Ankylosing Spondylitis	10 mL	twice a day
Pain relief for minor aches and pains in muscles, bones and joints/Relief of pain and inflammation in sprains and strains	15 mL	twice a day
	OR	
	10 mL	three times a day
Painful menstruation	First dose only: 20 mL	Once
	Following dose(s): 10 mL	Every 6-8 hours, as needed
	OR	
	20 mL	Twice a day

Do not increase the starting dose unless directed by your doctor.

Usual dose: Juvenile Rheumatoid Arthritis (2-16 years):

The recommended total daily dose in children aged 2 and up is approximately 5 mg/kg, every 12 hours. See the following dosing guide:

Child's weight	Dose (25 mg per mL)	Dose Frequency
13 kg (29 lbs.)	2.6 mL	twice a day (12 hours apart)
15 kg (33 lbs.)	3 mL	
20 kg (44 lbs.)	4 mL	
25 kg (55 lbs.)	5 mL	
30 kg (66 lbs.)	6 mL	
40 kg (88 lbs.)	8 mL	
50 kg (110 lbs.)	10 mL	

Missed Dose:

It may be a good idea to ask your doctor or pharmacist ahead of time what to do about missed doses. If you forget to take a dose of PEDIAPHARM NAPROXEN SUSPENSION take it as soon as possible, then just carry on with the regular times you take your medication. If you remember your missed dose close to the time of your next dose, do not take the missed dose.

Overdose:

In case of drug overdose, contact a health care practitioner, hospital emergency department or regional Poison Control Centre immediately, even if there are no symptoms.

INSTRUCTIONS FOR USE

The following supplies to draw up the dose of PEDIAPHARM NAPROXEN SUSPENSION (**Figure 1**) are included in the box:

- PEDIAPHARM NAPROXEN SUSPENSION bottle
- Press-in bottle adapter
- Oral dosing syringe

Figure 1

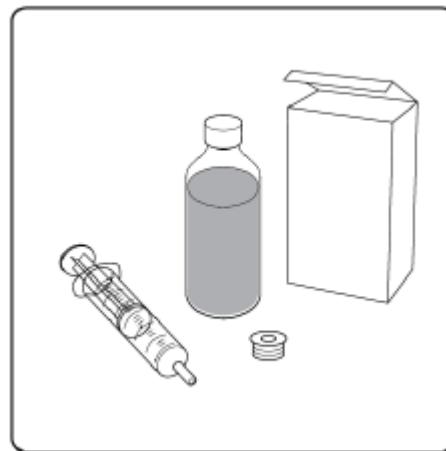

How to insert the PEDIAPHARM NAPROXEN SUSPENSION press-in bottle adapter:

You will only have to follow these steps the first time you use a bottle of PEDIAPHARM NAPROXEN SUSPENSION. Once the press-in bottle adapter is inserted it cannot be removed.

Step 1. Firmly insert the press-in bottle adapter into the bottle. See **Figure 2**.

Figure 2

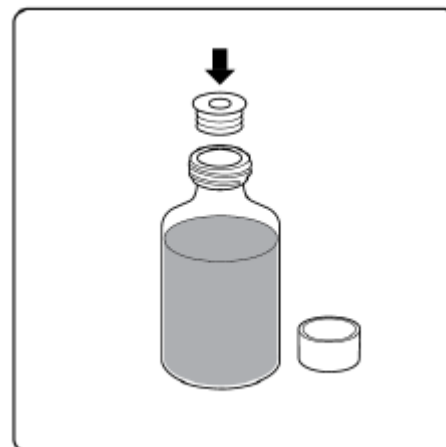

Step 2. Make sure the press-in bottle adapter has been pushed in far enough. The press-in bottle adapter should be flush with the top of the bottle opening after it is inserted. See **Figure 3**.

Figure 3



How to measure a dose of PEDIAPHARM NAPROXEN SUSPENSION:

If this is the first time you are using the bottle of PEDIAPHARM NAPROXEN SUSPENSION see the instructions above for how to insert the press-in bottle adapter.

Step 1. Shake the bottle gently before each use. See **Figure 4**.

Figure 4



Step 2. With the bottle in an upright position, insert the oral dosing syringe into the bottle adapter and push the plunger all the way down. See **Figure 5**.

Figure 5

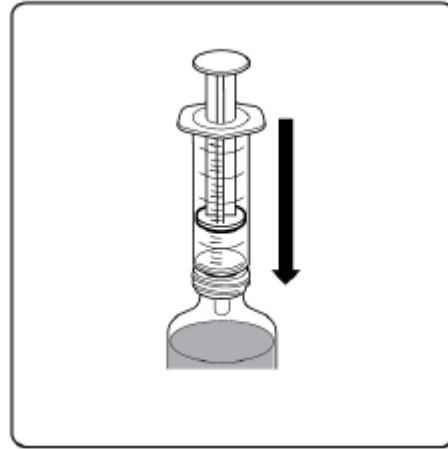

Step 3. With the oral dosing syringe in place, turn the bottle upside down. Pull the plunger to the number of mL needed. Measure the dose from the top black layer at the end of the plunger. See **Figure 6**.

If the dose is more than 10 mL, you will have to measure the medicine twice – first for the 10 mL, then for the remainder needed to complete the dose.

Figure 6

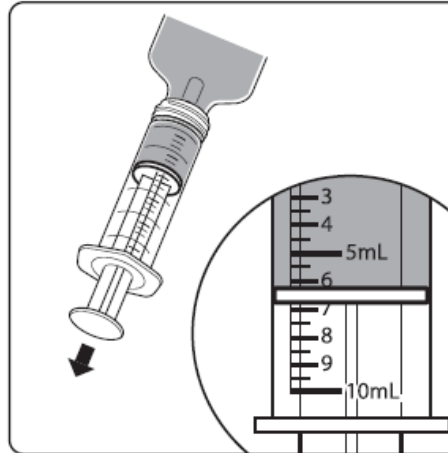

Step 4. Turn the bottle so it is upright and remove the oral dosing syringe. Place the oral dosing syringe in the patient's mouth. Slowly press down on the plunger to squirt the dose of PEDIAPHARM NAPROXEN SUSPENSION into the corner of the mouth. See **Figure 7**.

Figure 7



Step 5. Rinse the oral dosing syringe with tap water and allow it to air dry after each use.

Step 6. Cap the bottle tightly. The cap will fit over the bottle adapter. Store the bottle in an upright position. See **Figure 8**.

Figure 8



Check with your health care provider **IMMEDIATELY** if you develop chills, fever, muscle aches or pains, or other flu-like symptoms, especially if they occur before or together with a skin rash. These symptoms may be the first signs of a **SERIOUS ALLERGIC REACTION** to this medication.

SERIOUS SIDE EFFECTS, HOW OFTEN THEY HAPPEN AND WHAT TO DO ABOUT THEM

Symptom	STOP taking PEDIAPHARM NAPROXEN SUSPENSION and get emergency medical attention IMMEDIATELY	Stop taking PEDIAPHARM NAPROXEN SUSPENSION and talk to your physician or pharmacist
Bloody or black tarry stools	✓	
Shortness of breath, wheezing, any trouble breathing or chest tightness	✓	
Skin rash, hives, swelling or itching	✓	
Blurred vision, or any visual disturbance	✓	
Any change in the amount or colour of your urine (red or brown)	✓	
Any pain or difficulty experienced while urinating		✓
Swelling of the feet, lower legs; weight gain		✓
Vomiting or persistent indigestion, nausea, stomach pain or diarrhea		✓
Yellow discolouration of the skin or eyes, with or without itchy skin		✓
Malaise, fatigue, loss of appetite		✓
Headaches, stiff neck		✓
Mental confusion, depression		✓
Dizziness, lightheadedness		✓
Hearing problems		✓

SIDE EFFECTS AND WHAT TO DO ABOUT THEM

PEDIAPHARM NAPROXEN SUSPENSION may cause some side effects, especially when used for a long time or in large doses. When these side effects occur, you may require medical attention. Report all symptoms or side effects to your health care provider.

PEDIAPHARM NAPROXEN SUSPENSION may cause you to become drowsy or tired. Be careful about driving or participating in activities that require you to be alert. If you become drowsy, dizzy or light-headed after taking PEDIAPHARM NAPROXEN SUSPENSION, do NOT drive or operate machinery.

PEDIAPHARM NAPROXEN SUSPENSION may cause you to become more sensitive to sunlight. Any exposure to sunlight or sunlamps may cause sunburn, skin blisters, skin rash, redness, itching or discolouration, or vision changes. If you have a reaction from the sun, check with your health care provider.

This is NOT a complete list of side effects. If you develop any other symptoms while taking PEDIAPHARM NAPROXEN SUSPENSION, see your health care provider.

HOW TO STORE IT

PEDIAPHARM NAPROXEN SUSPENSION: Store at room temperature not exceeding 25°C, with protection from light. Store upright.

Do NOT keep outdated medicine or medicine no longer needed. Any outdated or unused medicine should be returned to your pharmacist.

Keep out of reach of children.

REPORTING SIDE EFFECTS

You can report any suspected side effects associated with the use of health products to Health Canada by:

- Visiting the Web page on Adverse Reaction Reporting (<https://www.canada.ca/en/health-canada/services/drugs-health-products/medeffect-canada/adverse-reaction-reporting.html>) for information on how to report online, by mail or by fax; or
- Calling toll-free at 1-866-234-2345.

NOTE: Contact your health professional if you need information about how to manage your side effects. The Canada Vigilance Program does not provide medical advice.

MORE INFORMATION

This document plus the full product monograph, prepared for health professionals can be found at:

<http://www.pediapharmnaproxen.ca>
or by contacting the sponsor, Pediapharm Inc., at:
1-877-630-5674.

This leaflet was prepared by Pediapharm Inc.

Last revised: March 15, 2018.