

PRODUCT MONOGRAPH

Pr DDAVP[®] Spray
Desmopressin Acetate Nasal Spray
10 µg/spray

Pr DDAVP[®] Rhinyle
Desmopressin Acetate Nasal Solution
0.1 mg/mL

Antidiuretic

Ferring Inc.
200 Yorkland Blvd, Suite 800
North York, Ontario
M2J 5C1

Date of Revision:
April 10, 2018

Date of Approval:
April 10, 2018

Submission Control No: 212637

Table of Contents

PART I: HEALTH PROFESSIONAL INFORMATION.....3
SUMMARY PRODUCT INFORMATION3
INDICATIONS AND CLINICAL USE.....3
ADVERSE REACTIONS.....7
DRUG INTERACTIONS **Error! Bookmark not defined.**
DOSAGE AND ADMINISTRATION8
OVERDOSAGE10
ACTION AND CLINICAL PHARMACOLOGY10
STORAGE AND STABILITY12
DOSAGE FORMS, COMPOSITION AND PACKAGING12

PART II: SCIENTIFIC INFORMATION13
PHARMACEUTICAL INFORMATION.....13
CLINICAL TRIALS.....14
TOXICOLOGY15
REFERENCES17

PART III: CONSUMER INFORMATION.....17

PrDDAVP® Spray
(Desmopressin Acetate Nasal Spray)

PrDDAVP® RHINYLE
(Desmopressin Acetate Nasal Solution)

PART I: HEALTH PROFESSIONAL INFORMATION

SUMMARY PRODUCT INFORMATION

Route of Administration	Dosage Form / Strength	Clinically Relevant Nonmedicinal Ingredients
Intranasal	Spray 10 µg/metered dose	DDAVP Spray: sodium chloride citric acid monohydrate, disodium hydrogen phosphate dihydrate, benzalkonium chloride
	Solution 0.1 mg/mL	DDAVP Rhinyle: sodium chloride, hydrochloric acid, chlorobutanol <i>For a complete listing see Dosage Forms, Composition and Packaging section.</i>

INDICATIONS AND CLINICAL USE

Diabetes Insipidus

DDAVP (desmopressin acetate) is indicated for the management of vasopressin sensitive central diabetes insipidus and for the control of temporary polyuria and polydipsia following head trauma, hypophysectomy or surgery in the pituitary region.

CONTRAINDICATIONS

- Hypersensitivity to desmopressin acetate or to any of the constituents.
- Type IIB or platelet-type (pseudo) von Willebrand's disease.
- Habitual or psychogenic polydipsia.
- Cardiac insufficiency or other conditions requiring treatment with diuretics.
- Moderate or severe renal insufficiency.

- Known hyponatremia.
- Primary Nocturnal Enuresis (PNE).
- Syndrome of inappropriate ADH secretion (SIADH)

Worldwide post-marketing data indicate a higher incidence of hyponatremia in patients being treated with the desmopressin intranasal formulations compared to the oral formulations (DDAVP Tablet and DDAVP Melt). Since safer formulations are available, intranasal formulations are contraindicated for use in primary nocturnal enuresis.

WARNINGS AND PRECAUTIONS

Hyponatremia is the most serious adverse event reported for desmopressin, resulting from water retention caused by the potent antidiuretic effect of desmopressin. Desmopressin may lead to water intoxication and/or hyponatremia. Unless properly diagnosed and treated, hyponatremia can be fatal. Therefore, fluid restriction is recommended and should be discussed with the patient and/or guardian. Careful medical supervision is required.

For intranasal use only. DDAVP (desmopressin acetate) is not effective in controlling polyuria caused by renal disease, nephrogenic diabetes insipidus, psychogenic diabetes insipidus, hypokalemia or hypercalcemia.

Fluid intake or desmopressin dosage should be adjusted in order to reduce the possibility of water retention and hyponatremia especially in very young and elderly patients or when significant daily variables occur such as hot climate conditions, intense exercise or other situations where increased water intake can be expected (see Dosage and Administration). Particular attention should be paid to the risk of an extreme decrease in plasma osmolality and resulting seizures in young children. Should prodromal symptoms of water retention occur (e.g. headache, nausea / vomiting, weight gain and, in severe cases, convulsions), which may herald impending hyponatraemia, treatment should be discontinued immediately and the patient should seek medical assessment.

Severe bladder dysfunction and outlet obstruction should be ruled out before starting treatment.

Changes in the nasal mucosa resulting from rhinitis, scarring, edema or other disease may cause erratic, unreliable absorption in which case intranasal desmopressin should not be used. In the case of temporary rhinitis, consideration should be given to using an injectable form of desmopressin, until the nasal mucosa returns to normal.

General

Desmopressin acetate at high dosage (40 µg or more) has very occasionally produced a slight elevation of blood pressure, which disappeared with a reduction in dosage. The drug should be used with caution in patients with coronary artery insufficiency and/or hypertensive cardiovascular disease because of possible tachycardia and changes in blood pressure.

In the control of diabetes insipidus, the lowest effective dose should be used and the effective dosage, as determined by urine volume and osmolality and, in some cases, plasma osmolality, should be assessed periodically.

Desmopressin should not be administered to dehydrated patients until water balance has been adequately restored.

Desmopressin should be used with caution in patients with conditions associated with fluid and electrolyte imbalance such as cystic fibrosis, heart failure, and renal disorders because these patients are prone to hyponatremia. Treatment should be interrupted or carefully adjusted during acute intercurrent illnesses characterised by fluid and/or electrolyte imbalance (such as systemic infections, fever, gastroenteritis). When restarting treatment strict fluid restriction should be enforced.

Desmopressin should also be used with caution in patients at risk for increased intracranial pressure.

Children and geriatric patients should be closely observed for possible water retention due to over-ingestion of fluids. When fluid intake is not excessive, there is little danger of water intoxication and hyponatremia with the usual intranasal doses of desmopressin used to control diabetes insipidus. Fluid intake should be carefully adjusted to prevent over hydration.

There are reports of changes in response over time, usually when the drug has been administered for periods longer than 6 months. Some patients may show decreased responsiveness, others a shortened duration of effect. There is no evidence that this effect is due to the development of binding antibodies, but may be due to local inactivation of the peptide.

There is some evidence from post-marketing data for the occurrence of severe hyponatremia in association with the nasal spray formulation of desmopressin, when it is used in the treatment of cranial diabetes insipidus. DDAVP nasal spray should only be used in patients where orally administered formulations are not feasible.

Children, elderly and patients with serum sodium levels in the lower range of normal may have an increased risk of hyponatraemia. The hyponatraemia is reversible and in children it is often seen to occur in relation to changes in daily routines affecting fluid intake and/or perspiration.

Due to the presence of benzalkonium chloride DDAVP Nasal spray may cause bronchospasm.

Special Populations

Pregnant Women

Reproductive studies performed in rats and rabbits have revealed no evidence of harm to the fetus by desmopressin. The use of desmopressin in pregnant women with no harm to the fetus has been reported. However, no controlled studies in pregnant women have been carried out.

One investigator has reported three cases of malformations in children born to mothers suffering from diabetes insipidus and receiving desmopressin during pregnancy. However, several other published reports comprising more than 120 cases showed that women treated with desmopressin during pregnancy have given birth to normal children. Furthermore, a review of a very large data set identifying 29 children who were exposed to desmopressin during the entire pregnancy showed no increase in the malformation rate in the children born. Unlike preparations containing the natural hormone, DDAVP in antidiuretic doses has no uterotonic action, but the physician should weigh possible therapeutic advantages against potential risks in each case.

Nursing Women

There have been no controlled studies in nursing mothers. A single study on a post-partum woman demonstrated a marked change in maternal plasma desmopressin level following an intranasal dose of 10 µg, but little desmopressin was detectable in breast milk. Results from analysis of milk from nursing mothers receiving high doses of desmopressin (300 µg intranasal), indicate that the amounts of desmopressin that may be transferred to the child are considerably less than the amounts required to influence diuresis.

Pediatrics

DDAVP (desmopressin acetate) has been used in children with diabetes insipidus. The dose must be individually adjusted to the patient with attention in the very young to the danger of an extreme decrease of plasma osmolality with resulting convulsions. Dosage in infants younger than 3 months has not been established. Dose should start at 5 µg or less. Use of desmopressin in infants and children will require careful fluid intake restriction to prevent possible hyponatremia and water intoxication.

Administration of DDAVP nasal spray or solution in children should occur under adult supervision, in order to ensure the correct dosage intake.

Geriatrics

Older patients may be more sensitive to the antidiuretic effect of the usual adult dose of DDAVP. Patients over the age of 65 should be closely observed for possible water retention due to over-ingestion of fluids. Fluid intake should be carefully adjusted to prevent over-hydration.

Monitoring and Laboratory Tests

Diagnosis of Central Diabetes Insipidus

Central diabetes insipidus may be demonstrated by the inability to produce urine of osmolality above 175 mOsm/kg with dehydration severe enough to cause a loss of greater than 2% of body weight.

Patients are selected for therapy by establishing a diagnosis by means of a water deprivation test, the hypertonic saline infusion test, and/or response to 5 units arginine vasopressin given s.c. after dehydration. Continued response to DDAVP can be monitored by urine volume and osmolality. In cases of severe dehydration, plasma osmolality determination may be required.

ADVERSE REACTIONS

Adverse Drug Reaction Overview

The most serious adverse reaction with desmopressin is hyponatraemia/water retention, which is associated with headache, nausea, vomiting, decreased serum sodium, weight increase, malaise, muscle cramps, confusion, and in severe cases convulsions and coma.

High doses of desmopressin have produced transient headache and nausea. Nasal congestion, rhinitis, high body temperature, flushing, and mild abdominal cramps have also been reported. These symptoms disappeared with reduction in dosage.

Very rare cases of emotional disturbances (affect lability, nightmare, nervousness and aggression) in children have been reported. Isolated cases of allergic skin reactions and more serious general allergic reactions have been reported.

Other common adverse reactions were upper respiratory tract infection and gastroenteritis.

Side effects reported from controlled clinical trials involving 638 subjects included headache (2%), rhinitis (1%), nasal discomfort (1%), epistaxis (1%) and abdominal pain (1%). Other effects, reported at a frequency of less than 1%, included dizziness, chills, wheezing, rash, edema of face and hands, nausea, constipation, anorexia, increased appetite, conjunctivitis and after taste in the mouth. These symptoms disappeared with reduction of dosage or withdrawal of drug. Adverse effects rarely necessitated discontinuance of the drug.

Post-Market Adverse Drug Reactions

Desmopressin is a potent antidiuretic, which may lead to water intoxication and/or hyponatremia. Hyponatremia has been reported at an approximate rate of 5 cases per 10 million doses from worldwide post marketing experience in patients treated with DDAVP intranasal formulations. The reported rate for DDAVP oral formulations worldwide is considerably less at about 1 case per 10 million doses. Patients are recommended to take the oral formulations (e.g., DDAVP Melt) which are available for children with PNE.

Unless properly diagnosed and treated, hyponatremia can be fatal. Therefore, fluid restriction is recommended and should be discussed with the patient and/or guardian. Careful medical supervision is required.

Severe general allergic reactions have been reported.

Other adverse events reported include: dehydration, somnolence, fatigue, hypertension, dyspnea, diarrhea, pruritis, muscle spasms, rash and urticaria, peripheral edema, chest pain and chills.

DRUG INTERACTIONS

Overview

Clofibrate, chlorpropamide) and carbamazepine) are known to potentiate the antidiuretic activity of desmopressin leading to an increased risk of water retention/hyponatremia, while demeclocycline, lithium and norepinephrine may decrease its activity. Indomethacin increases the urine concentrating effect of desmopressin without influencing the duration. The effect is probably without any clinical significance.

Although the pressor activity of desmopressin is very low compared with the antidiuretic activity, use of large doses of desmopressin with other pressor agents should be done only with careful patient monitoring.

Precautions to avoid hyponatraemia, including careful attention to fluid restriction and more frequent monitoring of serum sodium, must be taken in case of concomitant treatment with drugs, which are known to induce SIADH, e.g. tricyclic antidepressants, selective serotonin reuptake inhibitors, such as chlorpromazine, and carbamazepine, and some antidiabetics of the sulfonylurea group particularly chlorpropamide, and in case of concomitant treatment with NSAIDs, since these may cause an additive antidiuretic effect leading to an increased risk of fluid water retention/hyponatraemia.

The selective serotonin reuptake inhibitors (SSRIs, venlafaxine and citalopram), and the neuroleptic risperidone have been associated with water intoxication and hyponatremia in rare cases.

DOSAGE AND ADMINISTRATION

Central Diabetes Insipidus

Central diabetes insipidus may be demonstrated by the inability to produce urine of osmolality above 175 mOsm/kg with dehydration severe enough to cause a loss of greater than 2% of body weight (see Laboratory Tests).

Dosing Considerations

Dosage must be individualized but clinical experience has shown that the average daily dose for adults is 10 µg to 40 µg DDAVP (desmopressin acetate) and for children 3 months to 12 years of age, 5 µg to 30 µg. This may be given as a single dose or divided into two or three doses. About one third of patients can be treated with a single daily dose. Geriatric patients may be more sensitive to the antidiuretic effect of the usual adult dose of DDAVP.

Dosage in children with central diabetes insipidus up to 3 months of age has not been established.

DDAVP Spray is not indicated for use in children with Primary Nocturnal Enuresis (PNE).

Dosage

Children (3 months to 12 years)

The usual dose range is 5 µg to 30 µg daily either as a single dose or divided into two doses. About 1/3 of patients can be controlled by a single dose daily dose of DDAVP administered intranasally.

DDAVP Spray pump can only deliver 0.1 ml (10 µg) or multiples of 0.1 ml. In those children who require less than 10 µg, the rhinyle presentation should be used. In some patients, better control of polyuria is attained with smaller doses given at 6 to 8 hour intervals.

DDAVP Spray should be used in children who only require a single dose of 10 µg or more. The spray pump must be primed prior to use. To prime pump, press down four times. The bottle will now deliver 10 µg of drug.

Adult

Average daily dose is 10 µg to 40 µg. Most adults require 20 µg daily, administered in two divided doses (in the morning and the evening). Initially, therapy should be directed to control nocturia with a single evening dose. Response to therapy can be measured by the volume and frequency of urination and duration of uninterrupted sleep. The dosage of DDAVP should be adjusted according to the diurnal pattern of response, with the morning and evening doses being adjusted separately. Patients being switched from parenteral to intranasal administration generally require 10 times their maintenance intravenous dose intranasally.

In order to minimize the risk of hyponatremia, the following should be considered a part of individualized dosage titration;

- Desmopressin should be given with caution and the dosage adjusted as necessary during acute illness, febrile episodes, hot days and other conditions with increased water intake.

To institute therapy with DDAVP, patients should be withdrawn from previous medication and allowed to establish a baseline polyuria to permit determination of the magnitude and duration of the response to medication. In less severe cases, prior water loading may be desirable to establish a vigorous flow of urine. When the urine osmolality reaches a plateau at low level (in most cases, less than 100 mOsm/kg), the first dose of DDAVP (10 µg) is administered intranasally. A urine sample is obtained after two hours and hourly thereafter following DDAVP administration. Urine volume and osmolality are measured. When the patient has reached the previous baseline urine osmolality and urine flow, the drug effect has ceased and the next dose of DDAVP is administered. The cycle is then repeated until the patient has reached a stable condition.

In the event of signs of water retention/hyponatremia, treatment should be interrupted and the dose should be adjusted. When restarting treatment strict fluid restriction should be enforced.

OVERDOSAGE

Overdose of DDAVP nasal spray or nasal drops solution leads to a prolonged duration of action with an increased risk of water retention and hyponatraemia. Overdose symptoms include headaches, abdominal cramps, nausea, and facial flushing. There is no known antidote. However, the following general recommendations can be provided. Asymptomatic hyponatremia is treated by discontinuing the desmopressin treatment and fluid restriction. Infusion of isotonic or hypertonic sodium chloride may be added in cases with symptoms. When the water retention is severe (convulsions and unconsciousness) treatment with furosemide should be added.

For management of a suspected drug overdose, contact your regional Poison Control Centre.

ACTION AND CLINICAL PHARMACOLOGY

Mechanism of Action

Desmopressin is a synthetic structural analogue of the antidiuretic hormone, arginine vasopressin, which alters the permeability of the renal tubule to increase resorption of water. The increase in the permeability of both the distal tubules and collecting ducts appears to be mediated by a stimulation of the adenylcyclase activity in the renal tubules.

Approximately 10 to 20% of the dose of desmopressin solution administered intranasally is absorbed through the nasal mucosa. Antidiuretic effects occur within 1 hour, peak in 1 to 5 hours, persist for 8 to 20 hours and then abruptly end over a period of 60 to 90 minutes. Duration of action varies greatly among individuals and is dependent upon the rate of absorption from the nasal mucosa, persistence in plasma, and effect on renal tubules.

Pharmacodynamics

Maximum urine concentration was studied in 10 healthy adults (24 to 37 years of age) after administration of 20, 40 and 80 µg DDAVP intranasally with one week between each administration. Maximum effect on urine osmolality occurred between 3 and 5 hours (Figure 1), and the 20 µg dose was as effective as the higher doses. There were no side effects and mean body weight increase during the 24 hours after DDAVP administration did not exceed 0.5 kg after any dose.

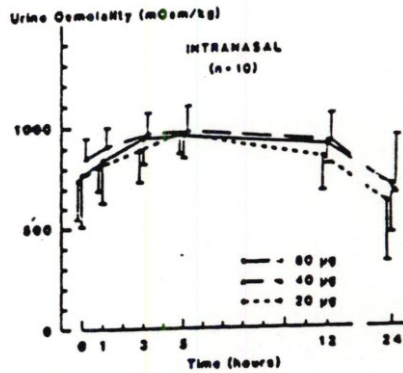

Figure 1

Urine osmolality after various doses of DDAVP given intranasally (mean \pm SD).

The use of DDAVP (desmopressin acetate) in patients with an established diagnosis of central diabetes insipidus will result in a reduction in urinary output with concomitant increase in urine osmolality and decrease in plasma osmolality. This will allow the resumption of a more normal lifestyle with a decrease in urinary frequency.

DDAVP does not directly affect urinary sodium or potassium excretion, or serum sodium, potassium, or creatinine concentrations. DDAVP does not stimulate uterine contractions, adrenocorticotrophic hormone release or increase plasma cortisol concentrations. In children, intranasal administration of DDAVP has no effect on growth hormone, prolactin, or luteinizing hormone concentration. Intranasal doses of 20 µg of DDAVP have no effect on blood pressure or pulse rate, but mean arterial pressure may increase as much as 15 mm Hg with doses of 40 µg or more.

Pharmacokinetics

Absorption

Following intranasal administration of DDAVP, approximately 10-20% of a dose is absorbed through the nasal mucosa. Patients with nasal congestion may require an increased dosage. Following intranasal administration of usual doses of DDAVP in patients with neurohypophyseal diabetes insipidus, antidiuretic effects occur within 1 hour, peak in 1-5 hours, persist for 8-20 hours, and then abruptly end over a period of 60-90 minutes. Duration of action varies among individuals with a specific dose. The relatively prolonged duration of action of DDAVP may result from slower enzymatic inactivation of desmopressin than vasopressin or from sequestration of DDAVP in a membrane compartment.

Distribution

The distribution of desmopressin has not been fully characterized. It is not known if desmopressin crosses the placenta. Some of the drug may be distributed into breast milk.

Excretion

In contrast to the elimination of DDAVP after intravenous injection, which is bi-exponential with a rapid first phase and slower second phase half-life of 7.8 minutes and 75.5-103 minutes, respectively, the disappearance of DDAVP from plasma after intranasal administration follows an exponential time course with half-lives ranging between 0.4 to 4 hours after intranasal application.

The metabolic fate of desmopressin is unknown. Unlike vasopressin, desmopressin apparently is not degraded by aminopeptidases or other peptidases that cleave oxytocin and endogenous vasopressin in the plasma during late pregnancy.

STORAGE AND STABILITY

DDAVP Spray: Store upright at room temperature, 15-30°C. Do not freeze. Store out of the reach of children.

DDAVP Rhinyle: Keep in the refrigerator at 2-8°C. Store out of the reach of children.

DOSAGE FORMS, COMPOSITION AND PACKAGING

Rhinyle

Each mL contains: desmopressin acetate 0.1 mg, equivalent to 89 mcg desmopressin in an isotonic, aqueous solution containing 0.5% chlorobutanol as a preservative. Bottles with plastic administration tube (Rhinyle). Two precalibrated and marked plastic administration tubes are included with each bottle.

Spray

Each pre-compression metered dose spray pump contains: desmopressin acetate 0.1 mg/mL, equivalent to 89 mcg desmopressin, in a buffered, isotonic, aqueous solution. Also contains benzalkonium chloride as a preservative. Each depression delivers desmopressin acetate 10 µg. Spray bottles of 2.5 mL containing 25 doses and 5 mL containing 50 doses.

PART II: SCIENTIFIC INFORMATION

PHARMACEUTICAL INFORMATION

Drug Substance

Proper name: Desmopressin Acetate Intranasal Solution

Chemical name: Desmopressin Acetate

Molecular formula and molecular mass:

(Acetate trihydrate) $C_{48}H_{74}N_{14}O_{17}S_2$ M.W. = 1183.2

(Free Base) $C_{46}H_{64}N_{14}O_{12}S_2$ M.W. = 1069.2

Structural formula:

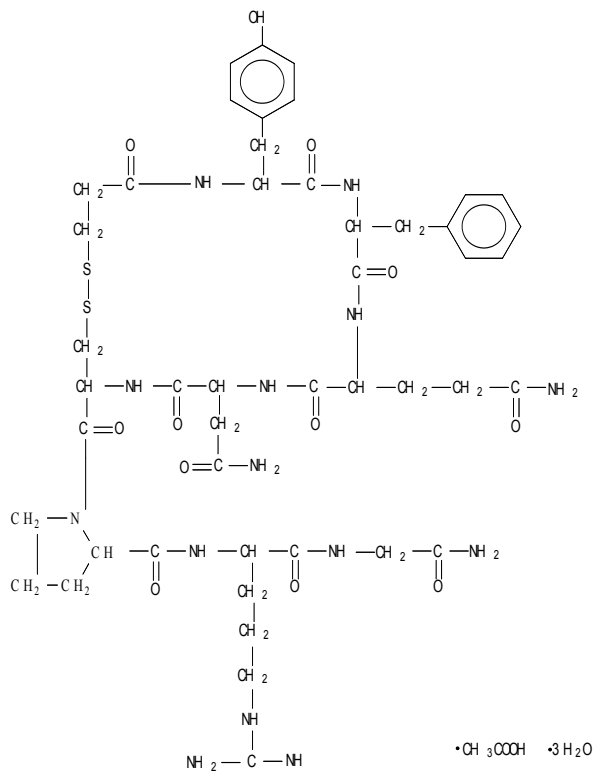

Physicochemical properties: Desmopressin acetate is a white lyophilized powder. It is soluble in water, ethanol, methanol, and acetic acid, and sparingly soluble in chloroform and ethyl acetate. An aqueous solution of 1 mg/mL at 24° C has a pH of 4.8.

CLINICAL TRIALS

Diabetes Insipidus

Central diabetes insipidus (CDI), characterized by polyuria and compensatory polydipsia, results from a lack of natural antidiuretic hormone (AVP). DDAVP administered to CDI patients compensates for the lack of AVP by altering kidney tubule permeability resulting in resorption of water. Seven patients with previously untreated hereditary, hypothalamic diabetes insipidus self-administered DDAVP intranasally (Table 1). Mean urine volume during DDAVP therapy was 1.77 litres/24 hours, compared to a mean 7.11 litres/24 hours prior to treatment. All patients maintained normal values of Hb concentration, haematocrit, WBC, differential count, and serum concentrations of sodium, potassium, calcium, and creatinine. Creatinine clearances were within normal limits, as were the morning levels of plasma cortisol. All showed a normal response to ACTH. Protein-bound iodine and I-tests were normal as were determinations of 17-keto and 17-hydroxy steroids. X-ray examination of femurs and humeri, with respect to fluorosis, revealed no abnormalities. There were no reported or observed side effects.

Table 1. Daily Urine Volumes Before, During, and Immediately After Withdrawal of Therapy with DDAVP Intranasally, According to Measurements Performed by the Patients at Home (Mean of Determinations on 3 Days)

Pat. No.	Sex	Age (yr)	Before treatment (1/24h)	DDAVP dose (µg)	During treatment (1/24h)	Treatment withdrawn (1/24h)
1	M	38	15.2	20 x 2	2.2	21.2
2	M	42	7.4	10 x 2	2.1	11.0
3	M	44	6.6	20 x 2	2.0	16.2
4	F	40	6.6	5 x 2	1.9	10.5
5	M	56	5.0	10 x 2	1.9	8.1
6	F	22	3.5	5 x 2	1.7	5.6
7	F	72	2.5	No treatment	No treatment	No treatment
8	F	6	3.0	3 x 2	0.6	4.5

TOXICOLOGY

Acute Toxicity

The acute toxicity of desmopressin acetate is very low (Table 2). Mice tolerate IV doses of 2 mg/kg. At IV doses of 30 µg/kg in rats and 50 µg/kg in rabbits, only transient changes in clinical behaviour were observed. Intravenous doses up to 24 µg/kg in dogs did not produce any cardiovascular changes.

Table 2. Acute Toxicity of DDAVP

Species	Number	LD ₅₀ Dose	Route	Reference
Mice	10 (both sexes)	> 2 mg/kg	IV	Vavra, 1968
Rats	12 (both sexes)	> 30 µg/kg	IV	Chau, 1982a
Rabbits	6 (both sexes)	> 50 µg/kg	IV	Chau, 1982b
Dogs	5 males	> 24 µg/kg	IV	Cort, 1978

Subacute Toxicity

Results from 14-day studies show that the drug given intravenously to rats at 18 µg/kg/day and to rabbits at 6 µg/kg/day caused no biologically significant changes in hematological and clinical chemistry parameters.

Rats which received 5 mg/kg/day subcutaneously for 3 weeks did not show any significant changes in weight, blood count, or organ changes.

Chronic Toxicity - (Subcutaneous Administration)

Rat Studies

In a controlled 8-week experiment, 20 rats received 2 µg/kg/day subcutaneous desmopressin acetate. No increase in blood glucose or morphological or histological pancreatic changes occurred. Rats (20 per group) which received desmopressin acetate doses of 5, 50 or 500 ng/kg/day, for 6 months did not show any significant changes in weight, blood values, or levels of transaminases. The weight of hearts, lungs, and kidneys decreased in female animals in the lower dose groups but not in the higher ones. In the male animals a decrease in non-esterifiable fatty acids was noted.

Dog Subcutaneous Studies

Dogs (3 per group) which received subcutaneous doses of 10 and 100 ng/kg/day desmopressin acetate for 6 months did not show any significant changes in comparison with control groups in blood sugar or transaminases and did not show histological or morphological organ changes.

Reproduction Studies

In teratogenicity testing in Wistar rats, no teratologic or embryotoxic effects were observed in 369 fetuses from 40 females dosed with up to 50 ng/kg/day desmopressin acetate subcutaneously on Day 1 through Day 20 of gestation.

In a study of 78 Dutch belted rabbits which received subcutaneous desmopressin acetate up to 10 µg/kg/day on Day 6 through Day 18 of pregnancy, no teratogenic or embryotoxic effects were observed in 296 fetuses. Weaning was unaffected.

REFERENCES

1. Andersson KE, Arner B, Furst E, and Hedner P. Antidiuretic responses to hypertonic saline infusion, water deprivation, and a synthetic analogue of vasopressin in patients with hereditary hypothalamic diabetes insipidus. *Acta. Med. Scand.* 195:17, 1974.
2. Burrow GN, Wassenaar W, Robertson GL, and Sehl H. DDAVP treatment of diabetes insipidus during pregnancy and the post-partum period. *Acta. End.* 97:23, 1981.
3. Chau, R. et al., Acute intravenous toxicity of DDAVP in rats, Revlon Health Care Group, October 29, 1982a.
4. Chau, R. et al., Acute intravenous safety of DDAVP in rabbits, Revlon Health Care Group, November 1, 1982b.
5. Cort, JH, Acute cardiological toxicity of ampouled desmopressin acetate. Mount Sinai School of Medicine, New York, January 15, 1978.
6. Davis JRE et al. Iatrogenic water intoxication in psychogenic polydipsia. *Scott. Med. J.* 26: 148, 1981.
7. Ferrer J et al. Acute water intoxication after intranasal desmopressin in a patient with primary polydipsia. *J. Endocrinol. Invest.* 13: 663, 1990.
8. Hilton P, and Stanton SL. The use of desmopressin (DDAVP) in nocturnal urinary frequency in the female. *Br. J. Urology* 54:252, 1982.
9. Hilton P, Hertogs K, and Stanton SL. The use of desmopressin (DDAVP) for nocturia in women with multiple sclerosis. *J. of Neur. Neurosurg. and Psychiatry* 46: 854, 1983.
10. Hutchon DJR, VanZijl JAWM, Campbell-Brown BM, and McFayden IR. Desmopressin as a test of urinary concentrating ability in pregnancy. *J. Obstet. Gyn.* 2:206, 1982.
11. Kvellén, BAJ et al. Diabetes insipidus and use of desmopressin (Minirin) during pregnancy. *Eur. J. of Endocrinol.* 132: 144-6 (1995).
12. Linder N, Matoth I, Ohel G, Yourish D, Tamir I. L-deamino-8-d-arginine vasopressin treatment in pregnancy and neonatal outcome. A report of three cases. *Am. J. Perinatol.* 3: 165, 1986.
13. Moses MA et al. Antidiuretic response to injection desmopressin, alone and with indomethacin. *J Clin. Endocrinol. Metab.* 52: 8910-8913 (1981).
14. Ray JG. DDAVP use during pregnancy: an analysis of its safety for mother and child. *Obstetrical and Gynecological Survey.* 53 (7) 450-455 (1998).

15. Singer I, and Forrest JN. Drug-induced states of nephrogenic diabetes insipidus. *Kidney Int.* 10:82, 1976.
16. Tryding N, Sterner G, Berg B, Harris A, and Lundin S. Subcutaneous and intranasal administration of Desamino-d-arginine vasopressin in the assessment of renal concentration capacity. *Nephron* 45:27-30 (1987).
17. Vavra I, Machova A, and Cort JH. Official translation of the pharmacological and toxicological report on DDAVP for the Ministry of Health, Prague, Czechoslovakia, 1968.

PART III: CONSUMER INFORMATION**PrDDAVP[®] Spray**

Desmopressin Acetate Nasal Spray
10 µg/spray

PrDDAVP[®] Rhinyle

Desmopressin Acetate Nasal Solution
0.1 mg/mL

This leaflet is part III of a three-part "Product Monograph" published when DDAVP[®] Spray and Rhinyle was approved for sale in Canada and is designed specifically for Consumers. This leaflet is a summary and will not tell you everything about DDAVP[®] Spray and DDAVP[®] Rhinyle. Contact your doctor or pharmacist if you have any questions about the drug.

ABOUT THIS MEDICATION**What the medication is used for:**

DDAVP[®] Spray and Rhinyle is used to prevent or control the frequent urination, extreme thirst, and loss of water associated with *Diabetes Insipidus (water diabetes)*, following head trauma and surgery in the pituitary gland.

Diabetes Insipidus (DI) is a medical condition in which your kidneys are unable to retain water. This results in the production of large volumes of urine which in turn makes you feel dry and very thirsty.

It is important to point out that DI is **not** related to the type of diabetes most people have heard of, Diabetes Mellitus (sugar diabetes).

In DI, there is no problem with the sugar in the blood or urine.

What it does:

DDAVP[®] Spray and Rhinyle contains desmopressin, an antidiuretic hormone. DDAVP[®] Spray and Rhinyle reduces the amount of urine that the body makes, thereby reducing symptoms of DI such as thirst and passing a lot of urine.

When it should not be used:

Do not take DDAVP[®] Spray and Rhinyle if any of the following conditions applies to you or your child:

- Allergic reaction to desmopressin acetate or any of the other ingredients in DDAVP[®] Spray and Rhinyle
- Bleeding problems such as Type II B or platelet-type (pseudo) von Willebrand's disease
- Excess fluid consumption
- Heart failure or other conditions requiring treatment with diuretics (water pills)
- Kidney problems or failure
- Hyponatremia (low blood sodium levels)
- Primary nocturnal enuresis (bedwetting)

- Syndrome of inappropriate ADH secretion (SIADH)

What the medicinal ingredient is:

Desmopressin acetate.

What the nonmedicinal ingredients are:

The nonmedicinal ingredients are:

DDAVP[®] Spray: sodium chloride, citric acid monohydrate, disodium hydrogen phosphate dihydrate and benzalkonium chloride.

DDAVP[®] Rhinyle: sodium chloride, hydrochloric acid and chlorobutanol.

What dosage forms it comes in:

DDAVP[®] Spray comes in a metered dose spray pump. The spray pump is constructed to administer 100 µL solution, equal to 10 µg desmopressin acetate. DDAVP[®] Spray comes in bottles of 2.5 mL containing 25 doses and 5 mL bottles containing 50 doses.

DDAVP[®] Rhinyle comes in a bottle with a plastic administration tube. Two precalibrated and marked plastic administration tubes are included with each bottle. One mark of the Rhinyle tube (0.05 mL) corresponds to 5 µg desmopressin acetate.

WARNING AND PRECAUTIONS**BEFORE you use DDAVP[®] Spray and Rhinyle talk to your doctor or pharmacist if you are:**

- Breast-feeding
- Pregnant or think you might be pregnant

And/or if you have:

- hyponatremia (low blood sodium level)
- heart problems
- liver disease
- kidney problems
- bleeding problems
- fever
- cystic fibrosis
- any allergies to desmopressin acetate or any of the ingredients listed in "What the nonmedicinal ingredients are"

Before you commence treatment with this medicine, you should receive appropriate advice concerning fluid intake from your doctor. Excessive fluid intake may lead to a build up of water in the body resulting in water intoxication and hyponatremia. Talk to your doctor if you develop conditions associated with fluid and electrolyte imbalance, such as infections, gastroenteritis, diarrhea and vomiting because these patients are prone to hyponatremia.

DDAVP[®] Spray and Rhinyle should not be given to dehydrated patients until water balance is adequately restored. Talk to your

doctor before stopping or interrupting treatment with DDAVP[®] Spray and Rhinyle.

Treatment should be stopped or carefully adjusted during any other acute illnesses characterised by fluid and/or electrolyte imbalance (such as systemic infections, fever, stomach flu/infectious diarrhea).

DDAVP Nasal spray may cause narrowing of the airways.

INTERACTIONS WITH THIS MEDICATION

Drugs that may interact with DDAVP[®] Spray and Rhinyle include:

- Tricyclic antidepressants (amitriptyline, nortriptyline)
- Serotonin reuptake inhibitors (for example, fluoxetine or Prozac[®], paroxetine or Paxil[®], sertraline or Zoloft[®], fluvoxamine or Luvox[®], citalopram or Celexa[®], venlafaxine or Effexor[®] XR, and risperidone or Risperdal[®])
- Nonsteroidal anti-inflammatory drugs (NSAIDs such as etodolac or Ultradol[®], ibuprofen or Advil[®] or Motrin[®], naproxen or Naprosyn[®]; celecoxib or Celebrex[®])
- Chlorpromazine
- Carbamazepine
- Diuretics (water pills)
- Loperamide or Imodium[®]
- Clofibrate
- Chlorpropamide
- Demeclocyclin
- Lithium
- Norepinephrine

If you are taking any of these drugs, please talk to your doctor or pharmacist before taking DDAVP[®] Spray and Rhinyle.

PROPER USE OF THIS MEDICATION

How to Take DDAVP[®] Spray:

DDAVP[®] Spray does NOT work like other nasal sprays. It is NOT supposed to be sniffed like cold or allergy sprays.

If it is sniffed up the nose, it will not work. The spray ONLY works when it is absorbed inside the nose.

Getting ready to use DDAVP[®] Spray:

Gently blow the nose. If the nose is blocked because of a cold or allergies, DDAVP[®] may not work as well.

Using Your DDAVP[®] Nasal Spray:

1. Do NOT shake the bottle.
2. Remove protective cap.
3. **The spray pump must be primed prior to the first use.** To prime pump, press down 4 times.

4. Once primed, the spray pump delivers 10 micrograms of medication each time it is pressed. To ensure dosing accuracy, tilt bottle so that dip tube inside the bottle draws from the deepest portion of the medication.

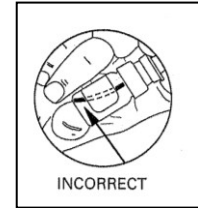
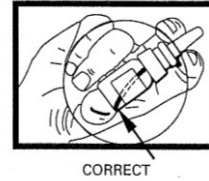

To administer one 10-microgram dose, place the spray nozzle in nostril and press the spray pump once. If a higher dose has been prescribed, spray half the dose in each nostril. The spray pump cannot be used for doses less than 10 micrograms or doses other than multiples of 10 micrograms.

5. Replace the protective cap on bottle after use. The pump will stay primed for up to one week. If the product has not been used for a period of one week, re-prime the pump by pressing once.

Using DDAVP[®] Spray for your child:

DDAVP[®] Spray should only be used in children who require a dose of 10 µg DDAVP[®] taken 1, 2 or 3 times daily.

Ask your child to gently blow his/her nose. If the nose is blocked because of a cold or allergies, DDAVP[®] may not work as well.

1. Do NOT shake the bottle.
2. Remove protective cap.
3. **The spray pump must be primed prior to the first use.** To prime pump, press down 4 times.
4. Once primed, the spray pump delivers 10 micrograms of medication each time it is pressed. To ensure dosing accuracy, tilt bottle so that dip tube inside the bottle draws from the deepest portion of the medication.
5. Always keep the bottle upright so the tube stays in the liquid and no air gets inside the tube. If an air bubble forms, the right amount of spray will not come out.

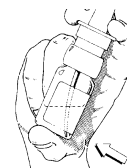

- Tilt the child's head back a little bit and insert the nozzle into one nostril.

Ask the child to take a deep breath in and hold his/her breath only while you spray DDAVP[®] into the nostril.

For each spray, press down firmly on the white collar using your index and middle fingers. Support the base of the bottle with your thumb.

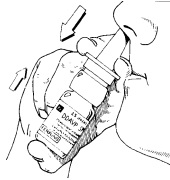

- Remove the nozzle from the child's nostril.
- Have your child place one finger on the outside of the nostril you just sprayed.
- Slowly count to 10 out loud. As you count, the child should hold the nostril closed so the spray will not drip out.
- When you reach 10, the child can release the finger and breathe normally.
- Replace the protective cap on bottle after use. The pump will stay primed for up to one week. If the product has not been used for a period of one week, re-prime the pump by pressing once.

Using DDAVP[®] Rhinyle:

Note: 0.05 mL solution contains 5 µg
 0.1 mL solution contains 10 µg
 0.2 mL solution contains 20 µg

- Pull plastic tag on neck of bottle and tear off security seal.
- Remove plastic cap and **retain for reclosure.**



- Twist-off the inner seal at the tip of the plastic teat and **retain for reclosure.**

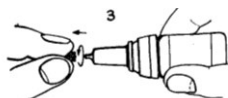

Take the arrow marked end of the rhinyle in one hand and place the finger and thumb of the other hand around the plastic teat.

Insert the tip of the plastic teat in a downward position into the arrow marked end of the rhinyle and gently squeeze the teat until the solution has reached the desired graduation mark.

N.B. In order to prevent air bubbles forming in the rhinyle, maintain steady pressure on the plastic teat.

If difficulty filling the rhinyle is experienced, a diabetic or tuberculin syringe may be used to draw up the dose and load the rhinyle tube.

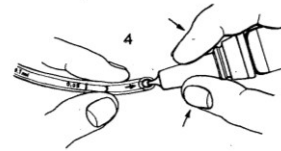

- Hold the rhinyle with the tips of finger and thumb 1 ½-2 cm from the arrow marked end and insert it into a nostril until the finger tips touch the nostril.
- Place the other end of the rhinyle in the mouth. Hold the breath, tilt back the head and then blow with a short strong puff through rhinyle so that the solution reaches the right place in the nasal cavity.

Through this procedure, medication is limited to the nasal cavity and the solution does not pass down the pharynx.



- After use, close the bottle using both the inner plastic tip seal (i) and the outer plastic cap (ii). **The use of both seals prevents wasteful loss by evaporation during refrigeration storage.**

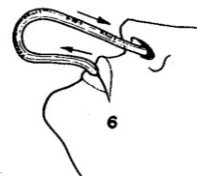

- Rinse the rhinyle under running water and shake thoroughly until no more water is left. The rhinyle can then be used for the next application



Using DDAVP® Rhinyle for your child:

Follow DDAVP® Rhinyle instructions Steps 1 to 7.

Note: Step 5 for children unable to perform the step on their own, place the other end of the Rhinyle in your mouth. Tilt back your child’s head and then blow with a short puff through rhinyle so that the solution reaches the right place in the nasal cavity.

Usual Dose

Take the medication only as directed by your doctor.

The doctor will prescribe the dose most suitable for you or your child. The most commonly used doses are:

Children (3 months to 12 years):

5–30 µg daily given as a single dose or divided into two or three doses.

Adults:

10-40 µg daily given as a single evening dose or divided into two or three doses.

Overdose:

If you or your child take too much of the medication, you should immediately contact your doctor and/or the emergency room of the nearest hospital and the local poison center. Symptoms of overdose may include headache, nausea, vomiting, abdominal cramps, facial flushing and weight gain due to water retention and, in severe cases, convulsions.

Missed dose:

If you miss a dose of DDAVP® Spray and Rhinyle, take the missed dose as soon as possible. Then go back to your regular dosing schedule. However, if it is almost time for your next dose, skip the missed dose and go back to your regular dosing schedule. Do not double dose.

SIDE EFFECTS AND WHAT TO DO ABOUT THEM

As with all medicines, side effects may be experienced. With DDAVP® Spray and Rhinyle, these may include:

Common Side Effects

Headache, nausea, mild abdominal pain, cramps or discomfort, stuffy nose, nasal irritation, facial flushing and nose bleed.

Uncommon Side Effects

Dizziness, feeling cold, wheezing, rash, swelling in the face and hands, constipation, anorexia (obsession with thinness generally sought through self-starvation), increased appetite (excessive desire for food), conjunctivitis (pink eye or red eye) and an after-taste in the mouth.

Rare Side Effects

Emotional problems in children and allergic skin reactions.

Severe general allergic reactions have been reported.

Other adverse events reported include: high blood pressure, shortness of breath, diarrhea, itchiness, rash and hives.

These have occurred usually when the medication is being adjusted. Once you are taking the right amount of medicine for your condition, these side effects will usually go away. Tell your doctor about any side effects you experience.

Excessive fluid intake may lead to a build up of water which dilutes the salt in the body in severe cases. This can become a serious problem and may lead to convulsions. Early symptoms may include an unusually bad or prolonged headache, confusion, unexplained weight gain, nausea and vomiting. If you experience one or more of these symptoms, stop taking this medicine. Tell your doctor immediately or go to the nearest emergency hospital.

SERIOUS SIDE EFFECTS, HOW OFTEN THEY HAPPEN AND WHAT TO DO ABOUT THEM				
Symptoms / effect		Talk with your doctor or pharmacist		Stop taking drug and call your doctor or pharmacist
		Only if severe	In all cases	
Rare	hyponatremia (low blood sodium level)		T	T
Very Rare	allergic reaction		T	T

This is not a complete list of side effects. For any unexpected effects while taking DDAVP® Spray and Rhinyle, contact your doctor or pharmacist.

HOW TO STORE IT

DDAVP® Spray should be stored at room temperature, 15-30° C. Do not freeze. Store in upright position.

Keep out of reach of children.

DDAVP® Rhinyle should be stored in refrigerator at 2 to 8° C. Keep out of reach of children.

REPORTING SUSPECTED SIDE EFFECTS

To monitor drug safety, Health Canada through the Canada Vigilance Program collects information on serious and unexpected side effects of drugs. If you suspect you have had a serious or unexpected reaction to this drug you may notify Canada Vigilance:

By toll-free telephone: 866-234-2345

By toll-free fax: 866-678-6789

Online: www.healthcanada.gc.ca/medeffect

By email: CanadaVigilance@hc-sc.gc.ca

By regular mail:

Canada Vigilance National Office
 Marketed Health Products Safety and Effectiveness
 Information Division
 Marketed Health Products Directorate

Health Products and Food Branch
 Health Canada
 Tunney's Pasture, AL 1980C
 Ottawa ON K1A 0K9

NOTE: Should you require information related to the management of the side effect, please contact your health care provider before contacting Canada Vigilance. The Canada Vigilance Program does not provide medical advice

MORE INFORMATION

For more information or help, call 1-866-384-1314

® Registered Trademark of Ferring BV



Ferring Inc., Toronto, Ontario

Last revised: April 10, 2018