

## PRODUCT MONOGRAPH

### **ROTARIX**

Human rotavirus, live, attenuated, oral vaccine

Oral suspension

Active immunizing agent

GlaxoSmithKline Inc.  
7333 Mississauga Road  
Mississauga, Ontario  
L5N 6L4

**Submission Control No.** 217121

**Date of Approval:** August 2, 2018

© 2018 GSK group of companies or its licensor  
Trademarks are owned by or licensed to the GSK group of companies.

## Table of Contents

<b>PART I: HEALTH PROFESSIONAL INFORMATION.....</b>	<b>3</b>
SUMMARY PRODUCT INFORMATION .....	3
DESCRIPTION.....	3
INDICATIONS AND CLINICAL USE.....	3
CONTRAINDICATIONS .....	3
WARNINGS AND PRECAUTIONS.....	4
ADVERSE REACTIONS.....	6
DRUG INTERACTIONS.....	11
DOSAGE AND ADMINISTRATION.....	11
OVERDOSAGE .....	12
ACTION AND CLINICAL PHARMACOLOGY .....	13
STORAGE AND STABILITY.....	15
SPECIAL HANDLING INSTRUCTIONS .....	15
DOSAGE FORMS, COMPOSITION AND PACKAGING .....	19
<b>PART II: SCIENTIFIC INFORMATION .....</b>	<b>20</b>
PHARMACEUTICAL INFORMATION.....	20
CLINICAL TRIALS.....	21
TOXICOLOGY .....	28
REFERENCES .....	28
<b>PART III: CONSUMER INFORMATION.....</b>	<b>31</b>

## ROTARIX

Human rotavirus, live, attenuated, oral vaccine

### PART I: HEALTH PROFESSIONAL INFORMATION

#### SUMMARY PRODUCT INFORMATION

Route of Administration	Dosage Form / Strength	Clinically Relevant Nonmedicinal Ingredients
Oral	Suspension/not less than $10^{6.0}$ CCID <sub>50</sub> of human rotavirus RIX4414 strain, per 1.5 mL dose.	Dulbecco's Modified Eagle Medium (DMEM), sucrose, di-sodium adipate, sterile water.  <i>For a complete listing see Dosage Forms, Composition and Packaging section.</i>

#### DESCRIPTION

ROTARIX (human rotavirus, live, attenuated, oral vaccine) is a suspension presented in monodose oral applicators or monodose tubes for oral administration. The vaccine includes an antacid component to protect the vaccine during passage through the stomach and prevent its inactivation due to acidic environment.

#### INDICATIONS AND CLINICAL USE

ROTARIX is indicated for active immunization of infants from the age of 6 weeks for the prevention of gastroenteritis caused by circulating rotavirus strains (see WARNINGS AND PRECAUTIONS and CLINICAL TRIALS).

The results from the clinical trials suggest that the vaccine's efficacy may vary with the type of rotavirus causing the infection (see CLINICAL TRIALS).

#### CONTRAINDICATIONS

ROTARIX should not be administered in:

- Infants who are hypersensitive to this drug or to any ingredient in the formulation or component of the container. For a complete listing, see the DOSAGE FORMS, COMPOSITION AND PACKAGING section of the product monograph.

- Infants who experienced hypersensitivity after previous administration of rotavirus vaccines.
- Infants with uncorrected congenital malformation (such as Meckel's diverticulum) of the gastrointestinal tract that would predispose for intussusception.
- Subjects with Severe Combined Immunodeficiency (SCID) disorder (see ADVERSE REACTIONS).
- Infants who have a history of intussusception.

## **WARNINGS AND PRECAUTIONS**

### **General**

It is good clinical practice that vaccination should be preceded by a review of the medical history (especially with regard to previous vaccination and possible occurrence of undesirable events) and a clinical examination.

As with other vaccines, administration of ROTARIX should be postponed in infants suffering from acute severe febrile illness. However, the presence of a minor infection such as a cold should not result in the deferral of vaccination.

No safety or efficacy data are available for the administration of ROTARIX to:

- Individuals who have received a blood transfusion or blood products, including immunoglobulins, within 42 days.

No efficacy data are available for the administration of ROTARIX to:

- Immunocompromised patients such as individuals with malignancies receiving immunosuppressive therapy or who are otherwise immunocompromised.

The administration of ROTARIX should be postponed in infants suffering from diarrhea or vomiting.

Post-marketing safety studies indicate an increased incidence of intussusception after vaccination, mostly within 7 days of the first dose and, to a lesser extent, the second dose. The overall incidence of intussusception remains rare. It has not been established whether ROTARIX affects the overall risk of intussusception (see ADVERSE REACTIONS, Clinical Trial Adverse Drug Reactions and Post-Marketing Adverse Drug Reactions).

As a precaution, healthcare providers should follow-up on any symptoms indicative of intussusception (severe abdominal pain, persistent vomiting, bloody stools, abdominal bloating and/or high fever). Parents/guardians should be advised to promptly report such symptoms.

For subjects with a predisposition for intussusception, see CONTRAINDICATIONS.

Excretion of the vaccine virus in the stools is known to occur after vaccination and lasts for 10 days on average with peak excretion around the 7th day. Viral antigen particles detected by ELISA were found in 50% (at day 7) of stools after the first dose and 17.4% (at day 3) and 4% (at day 7) of stools after the second dose. When these stools were tested for the presence of live vaccine strain, only 17% were positive. In clinical trials, cases of transmission of excreted vaccine virus to seronegative contacts of vaccinees have been observed without causing any clinical symptoms. ROTARIX should be administered with caution to individuals with immunodeficient close contacts, such as individuals with malignancies, or who are otherwise immunocompromised or receiving immunosuppressive therapy. Contacts of recent vaccinees should be advised to observe careful hygiene (including washing their hands) when changing children's diapers.

As with any vaccine, a protective immune response may not be elicited in all vaccinees.

The extent of protection that ROTARIX might provide against rotavirus strains that have not been circulating in clinical trials is currently unknown (see CLINICAL TRIALS).

ROTARIX does not protect against gastroenteritis due to other pathogens than rotavirus.

No data are available on the use of ROTARIX for post-exposure prophylaxis.

**UNDER NO CIRCUMSTANCES SHOULD ROTARIX BE INJECTED.**

### **Gastrointestinal**

There are no data on the safety and efficacy of ROTARIX in infants with gastrointestinal illnesses. Administration of ROTARIX may be considered with caution in such infants when, in the opinion of the physician, withholding the vaccine entails a greater risk.

### **Immune**

In some clinical trials, ROTARIX was not administered to infants known to have immunodeficient household members. There is a theoretical risk that the live virus vaccine can be transmitted to non-vaccinate contacts. Therefore, ROTARIX should be administered with caution to individuals known to have immunodeficient close contacts such as:

- Individuals with malignancies or who are otherwise immunocompromised; or
- Individuals receiving immunosuppressive therapy.

However, because nearly all children are infected with naturally occurring rotavirus by the age of 5 years, vaccination of infants may decrease the risk of exposure of immunodeficient household contacts to naturally occurring rotavirus. The health care provider should assess the potential risks and benefits of administering ROTARIX to infants known to have immunodeficient close contacts.

Asymptomatic and mildly symptomatic HIV infections are not expected to affect the safety or efficacy of ROTARIX. A clinical study in a limited number of asymptomatic or mildly symptomatic HIV positive infants showed no apparent safety problems (see ADVERSE REACTIONS, Safety in Infants with Human Immunodeficiency [HIV] Infection). Administration of ROTARIX in immunosuppressed infants, including infants on immunosuppressive therapy, should be based on careful consideration of potential benefits and risks.

### **Sensitivity/Resistance**

The vaccine contains 1073 mg of sucrose as an excipient. This amount is too low to cause adverse events in patients with rare hereditary problems such as fructose intolerance, glucose-galactose malabsorption or sucrase-isomaltase insufficiency.

### **Special Populations**

**Breastfeeding Infants:** Evidence from some clinical trials with ROTARIX suggests breastfeeding does not reduce the protection against rotavirus gastroenteritis afforded by ROTARIX. Therefore breastfeeding may be continued during the vaccination schedule.

**Pregnant Women:** ROTARIX is not intended for use in adults. Thus, human data on use during pregnancy are not available and animal reproduction studies have not been performed.

## **ADVERSE REACTIONS**

### **Adverse Drug Reaction Overview**

The safety profile presented below is based on data from clinical trials conducted with either the lyophilized or the liquid formulation of ROTARIX.

In a total of four clinical trials, approximately 3,800 doses of ROTARIX liquid formulation were administered to approximately 1,930 infants. Those trials have shown that the safety and reactogenicity profile of the liquid formulation is comparable to the lyophilized formulation.

In a total of twenty-three clinical trials, approximately 106,000 doses of ROTARIX were administered to approximately 51,000 infants.

In three placebo controlled clinical trials (Finland, India and Bangladesh), in which, ROTARIX lyophilized formulation was administered alone (administration of routine pediatric vaccines was staggered), the incidence and severity of the solicited events (collected 8 days post vaccination), diarrhea, vomiting, loss of appetite, fever, irritability and cough/runny nose, were not significantly different in the group receiving ROTARIX when compared to the group receiving placebo. No increase in the incidence or severity of these events was seen with the second dose.

## **Clinical Trial Adverse Drug Reactions**

*Because clinical trials are conducted under very specific conditions the adverse reaction rates observed in the clinical trials may not reflect the rates observed in practice and should not be compared to the rates in the clinical trials of another drug. Adverse drug reaction information from clinical trials is useful for identifying drug-related adverse events and for approximating rates.*

### **Intussusception (also see Post-Marketing Adverse Drug Reactions)**

The risk of intussusception has been evaluated in a large safety trial conducted in Latin America and Finland where 63,225 infants were enrolled. No increased risk of intussusception in the ROTARIX group was observed and observed rates were comparable to the placebo group. Data are shown below in Table 1 and Table 2.

**Table 1 Rate of intussusception within 31 days after administration**

<b>Intussusception</b>	<b>ROTARIX</b>	<b>Placebo</b>	<b>Relative risk (95% CI)</b>
	N=31,673	N=31,552	
First dose	1	2	0.50 (0.07;3.80)
Second dose	5	5	0.99 (0.31;3.21)

CI: Confidence Interval

**Table 2 Rate of intussusception up to one year of age**

<b>Intussusception</b>	<b>ROTARIX</b>	<b>Placebo</b>	<b>Relative Risk (95% CI)</b>
	N=10,159	N=10,010	
First dose up to one year	4	14	0.28 (0.10;0.81)

CI: Confidence Interval

### **Solicited adverse reactions**

In study Rota-036, detailed safety information was collected by parents/guardians for 8 consecutive days following vaccination with ROTARIX (i.e. day of vaccination and the next 7 days). A diary card was completed to record irritability, cough/runny nose, the infant's temperature, loss of appetite, vomiting, or diarrhea on a daily basis during the first week following each dose of ROTARIX or placebo. Adverse reactions among recipients of ROTARIX and placebo occurred at similar rates (see Table 3 below).

**Table 3 Percentage of subjects with each solicited general symptom assessed as causally related to vaccination, reported from Day 0 to Day 7 after each RV1 vaccine/placebo dose – Rota-036 Pooled countries (Czech Republic, Finland, France, Germany, Italy and Spain)**

Symptom	ROTARIX					Placebo				
	N	n	%	95 % CI		N	n	%	95 % CI	
				LL	UL				LL	UL
<b>Dose 1</b>										
Cough/Runny nose	914	58	6.3	4.9	8.1	490	29	5.9	4.0	8.4
Diarrhea	914	18	2.0	1.2	3.1	490	7	1.4	0.6	2.9
Fever	914	133	14.6	12.3	17.0	490	67	13.7	10.8	17.0
Irritability/Fussiness	914	299	32.7	29.7	35.9	490	171	34.9	30.7	39.3
Loss of appetite	914	126	13.8	11.6	16.2	490	71	14.5	11.5	17.9
Vomiting	914	44	4.8	3.5	6.4	490	24	4.9	3.2	7.2
<b>Dose 2</b>										
Cough/Runny nose	905	53	5.9	4.4	7.6	486	34	7.0	4.9	9.6
Diarrhea	905	6	0.7	0.2	1.4	486	8	1.6	0.7	3.2
Fever	905	164	18.1	15.7	20.8	486	95	19.5	16.1	23.4
Irritability/Fussiness	905	238	26.3	23.5	29.3	486	123	25.3	21.5	29.4
Loss of appetite	905	118	13.0	10.9	15.4	486	57	11.7	9.0	14.9
Vomiting	905	18	2.0	1.2	3.1	486	23	4.7	3.0	7.0

N = number of subjects having received the considered dose of RV1 vaccine/placebo  
n/% = number/percentage of subjects with the specified symptom reported for the considered dose  
95% CI: exact 95% confidence interval, LL = Lower Limit, UL = Upper Limit

Statistically significant differences were not detected between groups for the comparison between ROTARIX and placebo groups for the percentage of subjects with each specified solicited symptom (any, grade 3 and related) reported from Day 0 to Day 7 after any ROTARIX/placebo doses (P-value > 0.05 for each comparison).

In 17 placebo controlled clinical studies at day 8, assessment following vaccination, there were no statistically significant differences for irritability between ROTARIX group (60.8% of 8,333) and placebo group (57.2% of 2,936); irritability was assessed as related to vaccination in 36.9% of the subjects for the ROTARIX group. A statistically significant difference for grade 3 cough was detected between subjects who received ROTARIX (4.4% of 6,908) and Placebo (3.0% of 2,517) P-value: 0.0103.

### **Serious Adverse Events (SAEs):**

#### *Study Rota-023*

Among the total vaccinated cohort of 63,225 infants in study Rota-023 (31,673 in the RV1 group and 31,552 in the placebo group), a total of 1,975 subjects (948 infants in the RV1 vaccine group and 1,047 infants in the placebo group) reported at least one SAE (up to 30-90 days post Dose 2). No imbalance was observed between treatment groups for SAEs assessed as related to vaccination by the investigators. The overall SAE profile was



in favour of the RV1 vaccine with significantly fewer SAEs/hospitalizations reported in the RV1 vaccine group compared to the placebo group, especially with respect to preventing GE related SAEs.

In study Rota-023, a potential imbalance between groups was noted for Convulsions reported cases: 16 subjects in ROTARIX group (5.1/10,000) versus 6 subjects in the placebo group (1.9/10,000). However, no potential imbalance was noted between groups when SAEs related to "Convulsive disorders" were pooled ('Convulsions', 'Epilepsy', 'Grand mal convulsion', 'Status epilepticus' and 'Tonic convulsion'): 20 subjects in the ROTARIX group versus 12 in the placebo group.

#### *Other clinical trials*

Infants were monitored for serious adverse events that occurred in the 31 day period following vaccination in 8 clinical studies. In these eight trials, 608 subjects reported at least one SAE (450 in vaccinees and 158 in placebo recipients). The incidence of subjects reporting at least one SAE in the group receiving ROTARIX (8.12%, 95% CI: 7.41%; 8.87%) was similar to the incidence in the placebo group (8.53%, 95% CI: 7.30%; 9.90%).

#### **Deaths:**

In 8,262 infants enrolled and vaccinated in 10 completed trials, a total of 18 deaths were reported: 12 deaths in ROTARIX (0.19%, N=6,290) and 6 in placebo (0.30%, N=1,972). In the large safety study (Rota-023), 99 deaths occurred during the study<sup>a</sup>: 56 in ROTARIX group (N=31,673) and 43 in the placebo group (N=31,552). None of the cases were assessed as related to vaccination and no potential imbalance was detected for the 99 fatal cases in terms of overall mortality (P-value = 0.198).

#### **Safety in Preterm Infants:**

In a clinical study, 1,009 preterm infants were administered ROTARIX or placebo (198 were 27-30 weeks gestational age and 801 were 31-36 weeks gestational age). The first dose was administered from 6 weeks after birth. SAEs were observed in 5.1% of recipients of ROTARIX as compared to 6.8% of placebo recipients. Similar rates of solicited and unsolicited symptoms were observed in ROTARIX and placebo recipients. No cases of intussusception were reported. For premature infants born less than 36 weeks of gestation, and who remain hospitalized at the time of recommended administration, close monitoring for at least 48 hours after vaccination could be considered.

#### **Safety in Infants with Human Immunodeficiency (HIV) Infection**

In a clinical study, 100 infants with HIV infection were administered three doses of ROTARIX or placebo. The safety profile was similar between ROTARIX and placebo recipients.

---

<sup>a</sup> up to the data lock point.

### **Unsolicited Adverse Events (pooled analysis)**

Infants were monitored for unsolicited adverse reactions that occurred in the 31-day period following vaccination in 17 placebo controlled clinical studies (Europe, North America, Latin America, Asia, Africa) including trials in which ROTARIX was co-administered with routine pediatric vaccines (see DRUG INTERACTIONS). The following adverse reactions occurred at a statistically higher incidence (P-value < 0.05) among recipients of ROTARIX (N=10,212) as compared with placebo recipients (N=3,840):

**Table 4 Adverse reactions considered as being at least possibly related to ROTARIX vaccination**

<b>Frequency</b>	<b>Adverse Event</b>	<b>System/Organ Class</b>
Common: ≥ 1% and < 10%	Diarrhea	Gastrointestinal disorders
	Irritability	General disorders and administration site conditions
Uncommon: ≥ 0.1% and < 1%	flatulence, abdominal pain	Gastrointestinal disorders
	Dermatitis	Skin and subcutaneous tissue disorders

In these 17 placebo controlled clinical studies after a 31-day period following vaccination the following adverse reactions occurred at approximately the same frequency among recipients of ROTARIX (N=10,212) as compared with placebo recipients (N=3,840): irritability, loss of appetite, vomiting, regurgitation of food, fever, fatigue, crying, sleeping disorder, somnolence, constipation, upper respiratory tract infection, hoarseness, rhinorrhea, dermatitis, rash, muscle cramp. A relative risk of 1.18 was calculated for ‘bronchitis’, but the risk was not significantly higher as compared to the placebo group (p=0.3181).

### **Post-Marketing Adverse Drug Reactions**

The following events have been spontaneously reported during post-approval use of ROTARIX. Because these events were reported voluntarily from a population of uncertain size, it is not possible to reliably estimate their frequency or to establish a causal relationship to vaccine exposure.

**Gastrointestinal disorders:** Hematochezia, Intussusception\*<sup>^</sup>, Gastroenteritis with vaccine viral shedding in infants with Severe Combined Immunodeficiency (SCID) disorder.

\* See WARNINGS AND PRECAUTIONS

<sup>^</sup> Post-licensure studies and post-marketing spontaneous data suggest that intussusception following vaccination with ROTARIX is low and where it has been calculated, it occurs consistently at a rate less than 1 per 10,000 vaccinated infants (very rare) (see CLINICAL TRIALS).

**Infections and Infestations:** Kawasaki disease

## **DRUG INTERACTIONS**

### **Overview**

Immunosuppressive therapies may reduce the immune response to vaccines. The potential interaction of these therapies with ROTARIX is not known.

### **Use With Other Vaccines**

ROTARIX can be given concomitantly with any of the following monovalent or combination vaccines [including hexavalent vaccines (DTPa-HBV-IPV/Hib)]: diphtheria-tetanus-whole cell pertussis vaccine (DTPw), diphtheria-tetanus-acellular pertussis vaccine (DTPa), *Haemophilus influenzae* type b vaccine (Hib), inactivated polio vaccine (IPV), hepatitis B vaccine (HBV), pneumococcal conjugate vaccine and meningococcal serogroup C conjugate vaccine. Clinical studies demonstrated that the immune responses to and the safety profiles of the administered vaccines were unaffected.

In concomitant administration of ROTARIX and oral polio vaccine (OPV) clinical protection against severe rotavirus gastroenteritis was maintained. Concomitant administration of ROTARIX and OPV does not affect the immune response to the polio antigens but may reduce that to ROTARIX vaccine. The immune response to ROTARIX is unaffected when OPV is administered 2 weeks apart from ROTARIX.

## **DOSAGE AND ADMINISTRATION**

### **Dosing Considerations**

- ROTARIX is for **oral** use only.
- UNDER NO CIRCUMSTANCES SHOULD ROTARIX BE INJECTED.

### **Recommended Dose and Dosage Adjustment**

The vaccination course consists of two doses. The first dose can be administered from the age of 6 weeks. There should be an interval of at least 4 weeks between doses. ROTARIX may be given to preterm infants following the same vaccination course. This could be incorporated into the Canadian Immunization Schedule (2 and 4 months). Other immunization schedules have also been evaluated (see CLINICAL TRIALS). The administration of the 2 doses should be completed by the age of 24 weeks.

In particular circumstances, if the vaccine is given at an earlier age, and that the second dose is given within the shortest interval of 4 weeks, a lower immune response might be induced (see CLINICAL TRIALS, Protective efficacy of ROTARIX liquid formulation).

It is strongly recommended that infants who receive a first dose of ROTARIX complete the 2 dose regimen with ROTARIX. There are no data on safety, immunogenicity or efficacy when ROTARIX is administered for the first dose and another rotavirus vaccine is administered for the second dose or vice versa.

In clinical trials, spitting or regurgitation of the vaccine has rarely been observed and, under such circumstances, a replacement dose was not given. However, in the unlikely event that an infant spits out or regurgitates most of the vaccine dose, a single replacement dose may be given at the same vaccination visit.

There are no restrictions on the infant's consumption of food or liquid, including breastmilk, either before or after vaccination.

There is no evidence available to suggest that breastfeeding would reduce the protection against rotavirus gastroenteritis afforded by ROTARIX. Therefore, breastfeeding may be continued during the vaccination schedule.

The number of doses that would provide sufficient protection in immune compromised subjects has not been determined.

### **Administration**

See SPECIAL HANDLING INSTRUCTIONS.

### **OVERDOSAGE**

Some cases of overdose have been reported. In general, the adverse event profile reported in these cases was similar to that observed after administration of the recommended dose of ROTARIX.

For management of a suspected drug overdose, contact your regional Poison Control Centre.
---

## **ACTION AND CLINICAL PHARMACOLOGY**

Rotavirus infection is the leading cause of severe acute gastroenteritis in infants and young children throughout the world. Rotavirus is transmitted mainly by the fecal-oral route, through close person-to-person contact, and through fomites. Ingested virus particles infect the cells in the villi of the small intestine, typically leading to villous atrophy. Characteristic clinical features include diarrhea, vomiting, fever and abdominal discomfort, occasionally leading to fatal dehydrating illness. Improvements or increased efforts in hygiene and sanitation are known to be of limited efficacy.

Rotavirus infection affects 95% of children by the age of 3 to 5 years worldwide. The incidence of rotavirus infections is highest in children between 6 and 24 months of age. Primary infection after 3 months of age usually causes the most severe disease. Subsequent infections are possible but typically cause much milder symptoms.

In Canada, rotavirus gastroenteritis during the winter and spring seasons have been estimated as representing between 37% (Greater Toronto) to 71% (Quebec) of community acquired gastroenteritis cases resulting in hospitalization, in children aged less than 5 years. In Quebec, the annual number of hospitalizations for rotavirus gastroenteritis in 0-4 year olds was estimated as 2,000-2,500, representing 40-50% of the annual number of its hospitalizations for gastroenteritis in this age range within the province.

In the US and, based upon limited data in Canada, six rotavirus serotypes (P1A[8]G1, P1B[4]G2, P1A[8]G3, P1A[8]G4, P1A[8]G9, and P2A[6]G9) cause the majority of disease. These strains are generally designated by their G serotype specificity (serotypes G1-4 and G9). Approximately 55-65% of all rotavirus gastroenteritis in 2 Canadian studies were caused by G1 serotype. However, although non-G1 serotypes are generally less common, prevalence of individual serotypes varies year to year and geographically. Each of the other G serotypes can predominate in a given year.

Recent Canadian PHAC data from 2007-2009 demonstrates national rotavirus genotype prevalence is dominated by G1P[8] at 61.5%, followed by G3P[8] at 15.9%, G2P[4] at 8.4%, G9P[8] at 6.2%, and G4P[8] at 1.3%. It also noted an emergence of G9P[8] as a prevalent strain, at 6% of the genotypes detected.

Prospective surveillance data from the Canadian Immunization Monitoring Program, Active (IMPACT) collected between January 2005 and December 2007 included, 1,359 children who were hospitalized with lab-confirmed, community-acquired rotavirus gastroenteritis at the 12 IMPACT hospitals. More than 90% of the cases occurred between December and May, with the majority of cases in March and April. None of the 1,321 cases in which vaccination status was known had received rotavirus vaccine. The majority of cases (63%) occurred in infants  $\leq$  2 years; median age of cases was 1.5 years. Children under 2 years of age were significantly more likely to present with a clinical picture suggestive of sepsis (22.1%) compared with children between 2 and 16 years of

age (13.7%) ( $P < 0.001$ ) with 50% of children 0-3 months of age presenting with sepsis-like picture, a rate significantly higher than among children 4 to 23 months of age.

Out of the total of 1,359 children admitted to hospital, 48.6% had dehydration and the mean duration of diarrhea and vomiting prior to admission was 2.3 days and 2.4 days, respectively. Of these children, 68.5% had 1 Emergency Department visit, 26.4% had 2 visits, 4% had three visits, and 1% had four visits. Children spent an average of 7.9 hours in the Emergency Department prior to admission and were hospitalized for an average of 3.4 days. In total, 48 children (3.5%) required intensive care for a mean duration of 2.4 days; no children with community-acquired infection died.

Based upon available Canadian data it is estimated that rotavirus gastroenteritis is associated with considerable healthcare utilization including emergency room visits with approximately 36% of children with rotavirus seeing a physician, 15% visiting an emergency department, and 7% requiring hospitalization. The available published data demonstrate a considerable burden of illness due to rotavirus among Canadian children under the age of five years.

Updated IMPACT study data shows between 2011 and 2013, of the 1,592 hospitalizations for rotavirus infection documented at IMPACT sites, admission rates at sites in jurisdictions with publicly funded rotavirus immunization programs significantly decreased, while admission rates at sites in jurisdictions without immunization programs did not. In Ontario, when comparing rotavirus-specific gastroenteritis hospitalization in the post-vaccine period (Aug 2011 to Mar 2013) to the pre-vaccine period (Jan 2003 to July 2006), the relative risk of hospitalization adjusted for age and seasonality was 0.25 (95% confidence interval [CI] of 0.20 to 0.32), resulting in a 75% decrease in hospitalization [NACI, 2016].

### **Mechanism of Action**

ROTARIX contains a live, attenuated human rotavirus that replicates in the small intestine and induces immunity. ROTARIX vaccine is derived from the human 89-12 strain which belongs to G1 serotype and P[8] genotype. G1 is the most prevalent strain worldwide. It is known that the genotype P[8] is shared by most other circulating strains, including serotypes G3, G4 and G9.

The immunologic mechanism by which ROTARIX protects against rotavirus gastroenteritis is not completely understood. A relationship between antibody responses to rotavirus vaccination and protection against rotavirus gastroenteritis has not been established.

## **STORAGE AND STABILITY**

Store in a refrigerator (2°C to 8°C). Do not freeze.

In order to protect the vaccine from light it is recommended that the vaccine is stored in the original package.

The expiry date of the vaccine is indicated on the label and packaging.

## **SPECIAL HANDLING INSTRUCTIONS**

The vaccine is presented as a clear, colorless liquid, free of visible particles, for oral administration.

The vaccine is ready to use (no reconstitution or dilution is required).

The vaccine is to be administered orally without mixing with any other vaccines or solutions.

The vaccine should also be inspected visually for any foreign particulate matter and/or abnormal physical appearance prior to administration. In the event of either being observed, discard the vaccine. Any unused vaccine or waste material should be disposed of in accordance with local requirements.

This medicinal product must not be mixed with other medicinal products.

## Administration of the vaccine in oral applicator

1. Remove the protective tip cap from the **oral** applicator.

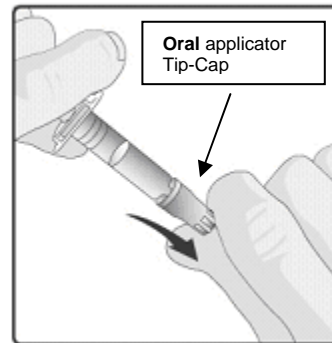

2. This vaccine is for **oral administration only**. The child should be seated in a reclining position. Administer **orally** (i.e. into the child's mouth towards the inner cheek) the entire content of the **oral** applicator.



3. **Do not inject.**

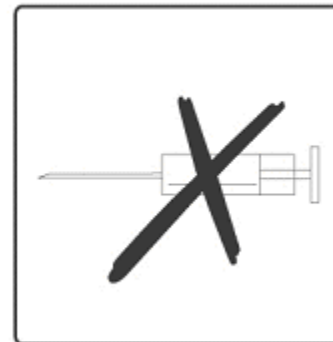



## Administration of the vaccine in tube

Please read the instructions for use all the way through before starting to give the vaccine.

### **A What you need to do before giving Rotarix**

- Check the expiry date.
- Check the tube has not been damaged nor is already open.
- Check the liquid is clear and colourless, without any particles in it.

If you notice anything abnormal, do not use the vaccine.

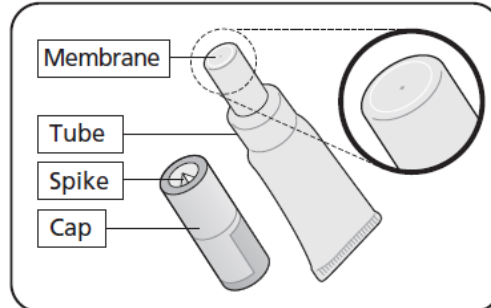

- This vaccine is given orally - straight from the tube.
- It is ready to use - you do not need to mix it with anything.

### **B Get the tube ready**

#### 1. Pull off the cap

- Keep the cap – you need this to pierce the membrane.
- Hold the tube upright.

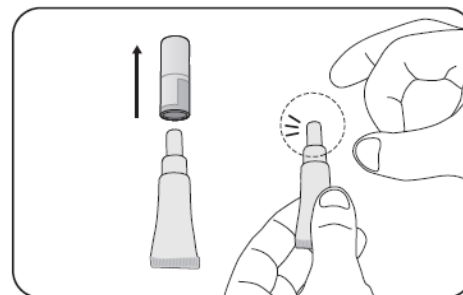

#### 2. Repeatedly flick the top of the tube until it is clear of any liquid

- Clear any liquid from the thinnest section of the tube by flicking just below the membrane.

#### 3. Position the cap to open the tube

- Keep the tube held upright.
- Hold the side of tube
- There is a small spike inside the top of the cap - in the centre.
- Turn the cap upside down (180°).

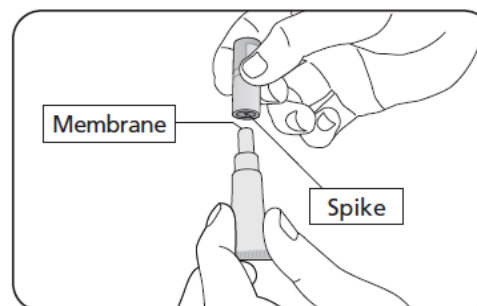

4. To open the tube

- You do not need to twist. Press the cap down to pierce the membrane.
- Then lift off the cap.

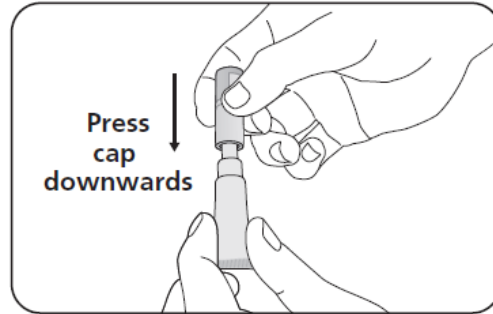

**C Check the tube has opened correctly**

1. Check the membrane has been pierced
  - There should be a hole at the top of the tube.
2. What to do if the membrane has not been pierced
  - If the membrane has not been pierced return to section B and repeat steps 2, 3 and 4.

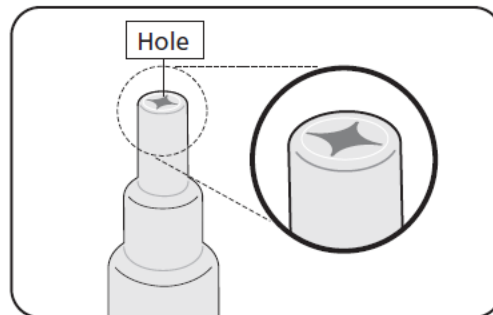

**D Give the vaccine**

- Once the tube is open check the liquid is clear, without any particles in it.  
If you notice anything abnormal, do not use the vaccine.
- Give the vaccine straight away.

1. Position the child to give the vaccine
  - Seat the child leaning slightly backwards.

2. Administer the vaccine

- Squeeze the liquid gently into the side of the child's mouth - towards the inside of their cheek.
- You may need to squeeze the tube a few times to get all of the vaccine out - it is okay if a drop remains in the tip of the tube.

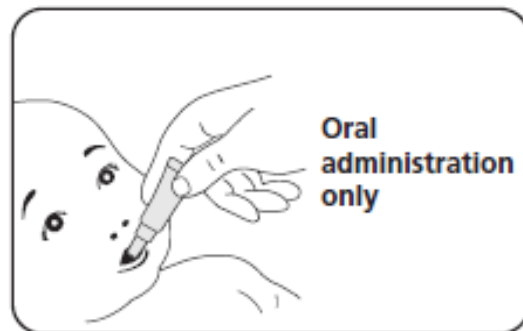

## **DOSAGE FORMS, COMPOSITION AND PACKAGING**

### **Dosage Form**

ROTARIX vaccine is available as an oral suspension (1.5 mL).

### **Composition**

Each 1.5 mL dose is formulated to contain not less than  $10^{6.0}$  CCID<sub>50</sub> of human rotavirus RIX4414 strain (live, attenuated), produced on Vero cells. Each dose also contains Dulbecco's Modified Eagle Medium (DMEM), sucrose, di-sodium adipate and sterile water. Residues: Porcine Circovirus type 1 (PCV-1) material has been detected in ROTARIX vaccine. PCV-1 is not known to cause disease in animals and is not known to infect or cause disease in humans. There is no evidence that the presence of PCV-1 poses a safety risk.

### **Packaging**

#### **Oral Applicator**

ROTARIX is available in an oral applicator (Type 1, Ph. Eur.) with a plunger stopper (butyl rubber) in pack sizes of 1, 5, 10, 25, 50 or 100.

#### **Tube**

ROTARIX is available in a squeezable tube (LDPE) fitted with a membrane and a cap (polypropylene) in pack sizes of 1\*, 10 or 50.

*\* pack size of 1 not currently available in Canada*

## **PART II: SCIENTIFIC INFORMATION**

### **PHARMACEUTICAL INFORMATION**

#### **Drug Substance**

Proper name: Human rotavirus, live, attenuated, oral vaccine.

#### **Product Characteristics**

ROTARIX (human rotavirus, live, attenuated, oral vaccine) is a monovalent, live, attenuated virus vaccine derived from the human 89-12 strain which belongs to G1 serotype and P[8] genotype. G1 is the most prevalent strain worldwide. It is known that the genotype P[8] is shared by most other circulating strains, including serotypes G3, G4 and G9. Natural infection with the virus is not limited to the G and P related antigens, but also is associated with the structural proteins VP2 and VP6, in addition to VP7 and VP4 as well as with the non-structural proteins such as NSP4. It has been shown that the induction of an immune response following vaccination with an attenuated G1P[8] human strain is sufficient to provide cross-protection against severe gastroenteritis linked to different G strains.

## CLINICAL TRIALS

- **Protective efficacy of ROTARIX lyophilized formulation**

Clinical studies have been conducted in Europe, Latin America, Africa and Asia to evaluate the protective efficacy of ROTARIX against any and severe rotavirus gastroenteritis.

**Table 5 Study demographics and trial design**

Study No.	Trial design	Dosage and route of administration	No. of subjects	Mean age at administration in weeks (range)	Gender
Rota-004	Multi-centre, double blinded, randomized, placebo controlled study	Oral 2 doses of $10^{4.7}$ foci forming units (ffu) at 2 and 4 months of age	<u>First efficacy follow-up:</u> 245 Vaccine 123 Placebo  <u>Second efficacy follow-up:</u> 241 Vaccine 120 Placebo	<u>First dose:</u> Vaccine: 8.3 (6-12) Placebo: 8.2 (6-12)  <u>Second dose:</u> Vaccine: 16.3 (10-12) Placebo: 16.1(13-22)	Vaccine: Male 53.5%  Placebo: Male: 50.4%
Rota-006	Multi-centre, multi-country, double blind, randomized, placebo controlled study	Oral 2 doses (of either $10^{4.7}$ , $10^{5.2}$ or $10^{5.8}$ foci forming units (ffu)) at 2 and 4 months of age	<u>First efficacy follow-up:</u> 1,392 Vaccine 454 Placebo  <u>Second efficacy follow-up:</u> 332 Vaccine 109 Placebo	<u>First dose:</u> Vaccine*: 8.3 (6-12) Placebo: 8.3 (6-12)  <u>Second dose:</u> Vaccine: 17.9 (13-28) Placebo: 17.9 (13-26)	Vaccine & Placebo Male: 52%
Rota-023	Multi-centre, multi-country, double blinded, randomized, placebo controlled study	Oral 2 doses of $10^{6.5}$ CCID <sub>50</sub> at 2 and 3 to 4 months of age <sup>1</sup>	<u>First efficacy follow-up:</u> 9,009 Vaccine 8,858 Placebo  <u>Second efficacy follow-up:</u> 7,175 Vaccine 7,062 Placebo	<u>First dose:</u> Vaccine: 8.4 (5-13) Placebo: 8.4 (2-13)  <u>Second dose:</u> Vaccine: 16.3 (10-36) Placebo: 16.3 (9-30)	Vaccine: Male: 50.1%  Placebo: Male: 52.0%
Rota-036	Multi-centre, multi-country, double blinded, randomized, placebo controlled study	Oral 2 doses of $10^{6.5}$ CCID <sub>50</sub> at a 2, 3 months, 2, 4 months, 3, 4 months or 3, 5 months schedule <sup>1</sup>	<u>First efficacy follow-up:</u> 2,572 Vaccine 1,302 Placebo  <u>Second efficacy follow-up:</u> 2,554 Vaccine 1,294 Placebo	<u>First dose:</u> Vaccine: 11.5 (5-18) Placebo: 11.5 (6-16)  <u>Second dose:</u> Vaccine: 19.7 (10-30) Placebo: 19.7 (10-27)	Vaccine: Male 53.6 %  Placebo: Male: 50.9%
Rota-037	Multi-centre, multi-country, double blinded, randomized, placebo controlled study <sup>†</sup>	Oral 2 doses of $10^{6.0}$ CCID <sub>50</sub> at 10, 14 weeks; or 3 doses at 6, 10, 14 weeks <sup>1</sup>	<u>First efficacy follow-up:</u> 2,974 Vaccine 1,443 Placebo	<u>First dose</u> <sup>‡</sup> : Vaccine: 6.3 (3-11) Placebo: 6.3 (2-11)  <u>Second dose</u> Vaccine: 11.3 (8-21) Placebo: 11.3 (9-19)	Vaccine: Male: 50.3%  Placebo: Male: 51.4%

Study No.	Trial design	Dosage and route of administration	No. of subjects	Mean age at administration in weeks (range)	Gender
				Third dose: Vaccine: 16.2 (12-26) Placebo: 16.3 (12-25)	

<sup>†</sup> The administration schedule depends on the countries in which the studies were conducted.

\* This is applicable to the 10<sup>5.8</sup> ffu titre vaccine

<sup>†</sup> The placebo group received 3 doses of placebo at 6, 10, 14 weeks. The two-dose vaccine group received vaccine at weeks 10 and 14, but also placebo at the first dose (6 weeks), such that all participants received three blinded doses.

Clinical studies on protective efficacy were undertaken with ROTARIX lyophilized formulation, on which ROTARIX approval was based. Subsequently, clinical studies were undertaken with the liquid formulation to assess the elicited immune response compared to the lyophilized formulation, including a non-inferiority study (see Protective efficacy of ROTARIX liquid formulation).

## Results

A clinical study performed in Europe (Rota-036) evaluated ROTARIX given according to different European schedules (2, 3 months; 2, 4 months; 3, 4 months; 3, 5 months) in more than 3,800 subjects. Severity of gastroenteritis was defined according to the Vesikari 20-point scale which evaluates the full clinical picture of rotavirus gastroenteritis by taking into account the severity and duration of diarrhea and vomiting, the severity of fever and dehydration as well as the need for treatment.

## Safety

For safety information refer to the Adverse Reactions section, Part 1

## Efficacy

**Table 6 Efficacy following two doses of ROTARIX persisting through the first and second rotavirus seasons (Rota-036)**

	1 <sup>st</sup> Rotavirus Season		2 <sup>nd</sup> Rotavirus Season	
	Efficacy (%)	95% CI	Efficacy (%)	95% CI
Any rotavirus gastroenteritis	87.1*	79.6;92.1	71.9*	61.2;79.8
Severe rotavirus gastroenteritis (Vesikari score ≥11)	95.8*	89.6;98.7	85.6*	75.8;91.9
Rotavirus gastroenteritis requiring medical attention	91.8*	84;96.3	76.2*	63.0;85.0
Hospitalization due to rotavirus gastroenteritis	100*	81.8;100	92.2*	65.6;99.1

\* Statistically significant (p<0.05)

Vaccine efficacy during the first year of life progressively increased with increasing disease severity, reaching 100% (95% CI: 84.7;100) for Vesikari scores ≥ 17.

**Table 7 Strain-specific efficacy in 2,572<sup>†</sup> ROTARIX vaccine recipients and 1,302<sup>†</sup> placebo recipients through 2 rotavirus seasons (Rota-036)**

Type	Through One Rotavirus Season				Through Two Rotavirus Seasons			
	Rotavirus gastroenteritis of any severity		Severe rotavirus <sup>^</sup> gastroenteritis		Rotavirus gastroenteritis of any severity		Severe rotavirus <sup>^</sup> gastroenteritis	
	Efficacy (%)	95% CI	Efficacy (%)	95% CI	Efficacy (%)	95% CI	Efficacy (%)	95% CI
G1[P8]	95.6*	87.9;98.8	96.4*	85.7;99.6	89.8*	82.9;94.2	96.4*	90.4;99.1
G2P[4]	62.0	-124.4;94.4	74.7	-386.2;99.6	58.3*	10.1;81.0	85.5*	24.0;98.5
G3[P8]	89.9*	9.5;99.8	100.0*	44.8;100.0	84.8*	41.0;97.3	93.7*	52.8;99.9
G4[P8]	88.3*	57.5;97.9	100.0*	64.9;100.0	83.1*	55.6;94.5	95.4*	68.3;99.9
G9[P8]	75.6*	51.1;88.5	94.7*	77.9;99.4	72.9*	59.3;82.2	85.0*	71.7;92.6
Strains with [P8] genotype	88.2*	80.8;93.0	96.5*	90.6;99.1	n.a	n.a	n.a	n.a
Pooled non G1 (G2, G3, G4, G9, G12)	n.a	n.a	n.a	n.a	72.9*	62.9;80.5	87.7*	78.9;93.2

<sup>†</sup>ATP cohort for efficacy

\* Statistically significant (p<0.05)

<sup>^</sup> Severe gastroenteritis defined as a score ≥ 11 on the Vesikari scale.

A clinical study performed in Latin America (Rota-023) evaluated ROTARIX in more than 17,500 subjects. Severity of gastroenteritis was defined according to WHO criteria. The protective vaccine efficacy against severe rotavirus gastroenteritis requiring hospitalization and/or rehydration therapy in a medical facility and the strain specific vaccine efficacy after 2 doses of ROTARIX are presented in Table 8.

**Table 8 Strain specific vaccine efficacy following 2 doses of ROTARIX (Rota-023)**

Type	Severe rotavirus gastroenteritis (1 <sup>st</sup> year of life) ROTARIX N=9,009; Placebo N=8,858		Severe rotavirus gastroenteritis (2 <sup>nd</sup> year of life) ROTARIX N=7,175; Placebo N=7,062	
	Efficacy (%)	95% CI	Efficacy (%)	95% CI
All rotavirus gastroenteritis	84.7*	71.7;92.4	79.0*	66.4;87.4
G1P[8]	91.8*	74.1;98.4	72.4*	34.5;89.9
G2P[4]	41.0	-79.2; 82.4	1.6	-7,626.1;98.6
G3P[8]	87.7*	8.3;99.7	71.9	-47.7;97.1
G4P[8]	50.8 <sup>#</sup>	-844;99.2	63.1*	0.7;88.2
G9P[8]	90.6*	61.7;98.9	87.7*	72.9;95.3
Strains with P[8] genotype	90.9*	79.2;96.8	79.5*	67.0;87.9

N=ATP cohort for efficacy

\*statistically significant (p<0.05)

<sup>#</sup> The numbers of cases on which the estimates of efficacy against G4P[8] were based were very small (1 case in the ROTARIX group and 2 cases in the placebo).

Due to the rareness of the G2P[4] serotype, a meta analysis was performed. A pooled analysis of four efficacy studies, listed in Table 5, showed a 71.4% (95% CI:20.1;91.1)

efficacy against severe rotavirus gastroenteritis (Vesikari score  $\geq 11$ ) caused by rotavirus G2P[4] type during the first year of life (see Table 9).

**Table 9 Pooled analysis of severe rotavirus G2P[4] gastroenteritis and ROTARIX efficacy in studies Rota-004, Rota-006, Rota-023, and Rota-036: 2 weeks after Dose 2 up to the end of the first year follow up**

Study	ROTARIX N= ATP cohort for Efficacy n=severe rotavirus gastroenteritis			Placebo N= ATP cohort for Efficacy n=severe rotavirus gastroenteritis			Vaccine Efficacy (VE) *	
	N	n	%	N	n	%	%	95% CI
<b>Rota-004</b>	245	0	0.0	123	1	0.8	100.0	-1,858.0;100.0
<b>Rota-006</b>	1,392	0	0.0	454	3	0.7	100.0	21.1;100.0
<b>Rota-023</b>	9,009	5	0.1	8,858	9	0.1	45.4	-81.5;85.6
<b>Rota-036</b>	2,572	1	0.0	1,302	2	0.2	64.7	-386.2;99.57
<b>All*</b>	13,218	6	0.0	10,737	15	0.1	71.4	20.1;91.1

Results from the first efficacy follow-up period on the ATP cohort for efficacy

\*VE defined as 1-stratified Poisson rate ratio

A clinical study performed in Africa (Rota-037) in more than 4,900 subjects evaluated ROTARIX given at approximately 10 and 14 weeks of age (2 doses, n=1,647) or 6, 10 and 14 weeks of age (3 doses, n=1,651). The 2- and 3-dose regimens were pooled and compared against placebo (n=1,641). The vaccine efficacy against severe rotavirus gastroenteritis (scored using the 20-point Vesikari scale) during the first year of life was 61.2 % (96.2 % CI: 42.9;73.7). The study was not powered to evaluate a difference in vaccine efficacy between the 2- and 3-dose regimens. The protective vaccine efficacy observed against any and severe rotavirus gastro-enteritis is presented in Table 10.



**Table 10 Study conducted in Africa: 1st year of life – pooled results (ROTARIX N=2,974; Placebo N = 1,443 (§))**

<b>Vaccine efficacy (%) against any rotavirus gastro-enteritis [95% CI ]*</b>		
<b>Strain</b>	<b>Any severity</b>	<b>Severe<sup>†</sup></b>
G1P[8]	68.3 [53.6;78.5]	56.6 [11.8;78.8]
G2P[4]	49.3 [4.6;73.0]	83.8 [9.6;98.4]
G3P[8]	43.4 [<0;83.7]	51.5 [<0;96.5]
G8P[4]	38.7 [<0;67.8]	63.6 [5.9;86.5]
G9P[8]	41.8 [<0;72.3]	56.9 [<0;85.5]
G12P[6]	48.0 [9.7;70.0]	55.5 [<0; 82.2]
Strains with P[4] genotype	39.3 [7.7;59.9]	70.9 [37.5;87.0]
Strains with P[6] genotype	46.6 [9.4;68.4]	55.2 [<0;81.3]
Strains with P[8] genotype	61.0 [47.3;71.2]	59.1 [32.8;75.3]

§ ATP cohort for efficacy

<sup>†</sup> Severe gastro-enteritis defined as a score  $\geq 11$  on the Vesikari scale

\* CI are unadjusted for interim analysis and multiplicity and should not be used to conclude on superiority over placebo

## **Immune response**

The immunologic mechanism by which ROTARIX protects against rotavirus gastroenteritis is not completely understood. A relationship between antibody responses to rotavirus vaccination and protection against rotavirus gastroenteritis has not been established. The following table shows the percentage of infants initially seronegative for rotavirus (IgA antibody titres < 20 U/mL (by ELISA)) and with serum anti-rotavirus IgA antibody titres  $\geq 20$  U/mL one to two months after the second dose of vaccine or placebo as observed in different studies (see Table 11).

**Table 11 Percent of infants with serum anti-rotavirus IgA antibody titres  $\geq 20$  U/mL 1 to 2 months after the second dose**

Schedule	Studies conducted in	Vaccine			Placebo		
		N	% $\geq 20$ U/mL	95% CI	N	% $\geq 20$ U/mL	95% CI
<b>2, 3 months</b>	France, Germany	239	82.8	77.5;87.4	127	8.7	4.4;15.0
<b>2, 4 months</b>	Spain	186	85.5	79.6;90.2	89	12.4	6.3;21.0
<b>3, 5 months</b>	Finland, Italy	180	94.4	90.0;97.3	114	3.5	1.0;8.7
<b>3, 4 months</b>	Czech Republic	182	84.6	78.5;89.5	90	2.2	0.3;7.8
<b>2, 3 to 4 months</b>	Latin America; 11 countries	393	77.9	73.8;81.6	341	15.1	11.7;19.0
<b>10, 14 weeks and 6, 10, 14 weeks (pooled)</b>	South Africa, Malawi	221	58.4	51.6;64.9	111	22.5	15.1;31.4

### **Immune Response in Preterm Infants**

In a clinical study conducted in preterm infants, ROTARIX was immunogenic; 85.7% of subjects achieved serum anti-rotavirus IgA antibody titres  $\geq 20$  U/mL (by ELISA) one month after the second dose of the vaccine.

- **Protective efficacy of ROTARIX liquid formulation**

Four controlled studies were undertaken with ROTARIX liquid formulation to assess elicited immune response. Three of these were comparative studies in which healthy infants were enrolled to receive two doses of ROTARIX liquid or lyophilized formulations, given at the age of 2 and 3 months (Rota-048), 2 and 4 months (Rota-057), or 3 and 4 months (Rota-061). The immune response elicited by ROTARIX liquid formulation was comparable to that elicited by the lyophilized formulation (see Table 12).

**Table 12 Percent of infants with serum anti-rotavirus IgA antibody titres  $\geq 20$ U/mL 1 month after the second dose**

Schedule	Studies conducted in	Liquid Formulation			Lyophilized Formulation		
		N	% $\geq 20$ U/mL	95% CI	N	% $\geq 20$ U/mL	95% CI
<b>2, 3 months</b>	Finland	80	90.0	81.2;95.6	86	83.7	74.2;90.8
<b>2, 4 months</b>	Panama	449	80.8	76.9;84.4	434	73.5	69.1;77.6
<b>3, 4 months</b>	Finland	746	88.6	86.1;90.8	252	90.5	86.2;93.8

In a study conducted in Vietnam (Rota-051), the immune response in terms of seroconversion rates and GMCs in the group that received two doses of ROTARIX liquid vaccine with the first and second dose given at 8 and 12 weeks of age (4 weeks apart) was lower than the response in the group that received two doses of ROTARIX liquid

vaccine with the first and second dose given at 8 and 16 weeks of age (8 weeks apart).

Serum anti-RV IgA antibodies are generally accepted as a valid surrogate marker of protection, and published data suggests that the ROTARIX-induced serum anti-RV IgA antibodies might be a good correlate of vaccine induced protection, despite the absence of an established immune correlate of protection. The immune response observed after two doses of ROTARIX liquid formulation was comparable to the immune response observed after 2 doses of ROTARIX lyophilized formulation, the vaccine efficacy for the liquid formulation is assumed to be similar to that observed with the lyophilized formulation.

### **Post-Authorization Safety Study**

A post-authorization safety study was undertaken in Mexico to evaluate the temporal association between ROTARIX administration (co-administered with other EPI vaccines) and definite intussusception occurrence within 31 days (Day 0 to Day 30) following vaccination. The analysis was performed on a cohort of children (N=698) diagnosed with intussusception, who had received at least one dose of rotavirus vaccine and with available dates of rotavirus vaccine administration, date of birth and onset date of intussusception. The study results indicated a temporal association between administration of ROTARIX and intussusception in the 31 days post Dose 1, and the effect was observed to be concentrated in the first week post Dose 1. The study results did not indicate a temporal association between ROTARIX and intussusception in the 31 days post Dose 2.

### **Post-Authorization Observational Studies**

A self controlled case series analysis and a matched case-control analysis were undertaken in infants immunized between July 2007 and June 2010 in Australia to evaluate cases of intussusception in the 21 day period following any vaccination with rotavirus vaccines. Data from this study indicate the likelihood of a small increased risk of intussusception following the first dose of ROTARIX. The study also found an increased risk of intussusception after Dose 2 of ROTARIX, but the risk was smaller than after Dose 1.

A meta-analysis of postmarketing surveillance studies conducted in Australia, Mexico, Brazil and the United States was performed to provide a single estimate of the risk of intussusception following the first and second dose of ROTARIX. The studies varied in terms of design and statistical power, and used different methods to estimate the risk; all studies included a risk estimation for the 7-day period after dose 1 and dose 2 separately, and obtained data through active and/or passive surveillance on confirmed intussusception cases. The overall estimate of risk of intussusception during the 7 days after vaccination was 5.39 (95% CI: 3.92; 7.41) after dose 1 and 1.81 (95% CI: 1.31; 2.49) after dose 2. These results indicate a transient increased incidence of intussusception after vaccination, mostly within 7 days of the first dose and, to a lesser extent, the second dose.

## TOXICOLOGY

Preclinical data reveal no special hazard for humans based on conventional studies of repeated dose toxicity.

## REFERENCES

1. Buettcher M, Baer G, Bonhoeffer J, Schaad UB, and Heininger U. Three-year surveillance of intussusception in children in Switzerland. *Pediatrics* 2007; 120:473-480.
2. Butz AM, Fosarelli P, Dick J, Cusack T, Yolken R. Prevalence of rotavirus on high-risk fomites in day-care facilities. *Pediatrics* 1993 Aug;92(2):202-5.
3. Bernstein DI, Ward RL. Rotaviruses. In: Feigin RD, Cherry JD, editors. *Textbook of pediatric infectious diseases*. 4th ed. Philadelphia: Saunders; 1998. p. 1901-22.
4. Carlin JB, Macartney K, Lee KJ, Quinn HE, Buttery J et al. Intussusception risk and disease prevention associated with rotavirus vaccines in Australia's national immunisation program. *Clinical Infectious Diseases* 2013;57(10):1427–1434.
5. Ford-Jones EL, Wang E, Petric M, Corey P, Moineddin R, Fearon M. Hospitalization for community-acquired, rotavirus-associated diarrhea: a prospective, longitudinal, population-based study during the seasonal outbreak. The Greater Toronto Area/Peel Region PRESI Study Group. *Pediatric Rotavirus Epidemiology Study for Immunization*. *Arch Pediatr Adolesc Med* 2000 Jun;154(6):578-85.
6. Han HH. Summary of Human Rotavirus Vaccine (ROTARIX): Safety and Efficacy Trials. Presentation at the European Expert Meeting on Rotavirus Vaccination, 2009 May 19-20; Tampere. Available at <http://www.uta.fi/laitokset/laaket/roketetutkimuskeskus/rotameeting2009/presentations/han.pdf>.
7. Huppertz HI, Soriano-Gabarró M, Grimprel E, Franco E, Mezner Z et al. Intussusception among young children in Europe. *Pediatr Infect Dis J*. 2006; 25:S22-29.
8. Le Saux N, Bettinger J, Halperin SA, Vaudry W, Scheifele WD for Members of the Canadian Immunization Monitoring Program, Active (IMPACT). Substantial Morbidity for Hospitalized Children with Community-Acquired Rotavirus Infections; 2005-2007 IMPACT Surveillance in Canadian Hospitals. *The Pediatric Infectious Disease Journal*. 2010, 29(9): 879-882

9. Madhi SA, Cunliffe NA, Steele D, Witte D, Kirsten M, Louw C, Ngwira B, Victor JC, Gillard PH, Chevart BB, Htay HH, Neuzil KM. Effect of Human Rotavirus Vaccine on Severe Diarrhea in African Infants. *N Engl J Med* 2010;362:289-98.
10. McDermid AK, LeSaux NM, Bettinger J, Dery P, Embree J, Vaudry W, Halperin S, Booth T. Rotavirus Serotypes: Results from an Impact Emergency Department Study. Poster presented at the 9th Canadian Immunization Conference, 2010 December; Quebec City, Canada. *Can J Infect Dis Med Microbiol* 2010;21(4):198-199.
11. NACI (National Advisory Committee on Immunization). Statement on Rotavirus Vaccines and Intussusception Public Health Agency of Canada; April 2016. URL: <https://www.canada.ca/en/public-health/services/publications/healthy-living/statement-rotavirus-vaccines-intussusception.html>.
12. Omenaca F, Wysocki J, Sarlangue J, Nogueira M, Suryakiran P, Smolenov I, et al. Safety, Reactogenicity and Immunogenicity of RIX4414 Live Attenuated Human Rotavirus Vaccine in Pre-Term Infants. Poster presented at ICAAC/IDSA Joint Meeting; 2008 Oct 25-28; Washington DC.
13. Omenaca F, Sarlangue J, Wysocki J, Nogueira M, Suryakiran P, Smolenov I, et al. Immunogenicity of a rotavirus vaccine (RIX4414) in European pre-term infants with different gestational age. Poster presented at the 27th annual ESPID meeting; 2009 Jun 9-13; Brussels, Belgium. The abstract can be downloaded from <http://www.kenes.com/espид09/abstracts/pdf/645.pdf>.
14. Online GlaxoSmithKline Clinical Study Register:  
Study Rota-054 Summary available at: <http://www.gsk-clinicalstudyregister.com/files/pdf/20098.pdf>.  
Study Rota-022 Summary available at: <http://www.gsk-clinicalstudyregister.com/files/pdf/20379.pdf>.
15. Ramachandran M, Gentsch JR, Parashar UD, Jin S, Woods PA, Holmes JL, et al. Detection and characterization of novel rotavirus strains in the United States. *J Clin Microbiol* 1998 Nov;36(11):3223-9.
16. Rivest P, Proulx M, Lonergan G, Lebel MH, Bedard L. Hospitalisations for gastroenteritis: the role of rotavirus. *Vaccine* 2004 May 7;22(15-16):2013-7.
17. Rosillon D, Buyse H, Friedland LR, Ng SP, Velázquez FR, Breuer T. Risk of intussusception after rotavirus vaccination: meta-analysis of postlicensure studies. *The Pediatric Infectious Disease Journal* 2015;34(7): 763-768.

18. Ruiz-Palacios GM, Perez-Schael I, Velazquez FR, Abate H, Breuer T, Clemens SC, et al. Safety and efficacy of an attenuated vaccine against severe rotavirus gastroenteritis. *N Engl J Med* 2006 Jan 5;354(1):11-22.
19. Ruuska T, Vesikari T. Rotavirus disease in Finnish children: use of numerical scores for clinical severity of diarrhoeal episodes. *Scand J Infect Dis* 1990;22(3):259-67.
20. Steele AD. The safety and immunogenicity of Rotarix in HIV positive infants in South Africa. Poster presented at the ICAAC/IDSA Joint Meeting; 2008 October 25-28; Washington DC.
21. The paediatric burden of rotavirus disease in Europe. *Epidemiol Infect* 2006 Oct;134(5):908-16.
22. Velázquez FR, Colindres RE, Grajales C, Hernandez MT, Mercadillo MG et al. Postmarketing surveillance of intussusception following mass introduction of the attenuated human rotavirus vaccine in Mexico. *Pediatric Infectious Disease Journal* 2012;31:736-744.
23. Waters V, Ford-Jones EL, Petric M, Fearon M, Corey P, Moineddein R. Etiology of community-acquired pediatric viral diarrhea: a prospective longitudinal study in hospitals, emergency departments, pediatric practices and child care centers during the winter rotavirus outbreak, 1997 to 1998. The Pediatric Rotavirus Epidemiology Study for Immunization Study Group. *Pediatr Infect Dis J* 2000 Sep;19(9):843-8.
24. WHO Strategic Advisory Group of Experts (SAGE) on Immunization, April 2009. Available at:  
[http://www.who.int/immunization/sage/3\\_Detailed\\_Review\\_Paper\\_on\\_Rota\\_Vaccines\\_17\\_3\\_2009.pdf](http://www.who.int/immunization/sage/3_Detailed_Review_Paper_on_Rota_Vaccines_17_3_2009.pdf).

**PART III: CONSUMER INFORMATION**

**ROTARIX**

Human rotavirus, live, attenuated oral vaccine

This leaflet is part III of a three-part "Product Monograph" published when ROTARIX (human rotavirus, live, attenuated oral vaccine) was approved for sale in Canada and is designed specifically for consumers. This leaflet is a summary and will not tell you everything about ROTARIX. Contact your doctor or pharmacist if you have any questions about the vaccine.

**ABOUT THIS VACCINE**

**What the vaccine is used for:**

ROTARIX is a viral vaccine, containing live, attenuated human rotavirus, that helps to protect your child against gastroenteritis (diarrhea and vomiting) caused by rotavirus infection.

Rotavirus infection is the most common cause of severe diarrhea in infants and young children. Rotavirus is easily spread from hand-to-mouth due to contact with stools from an infected person. Most children with rotavirus diarrhea recover on their own. However, some children become very ill with severe vomiting, diarrhea and life-threatening loss of fluids that requires hospitalization. Rotavirus infections are responsible for hundreds of thousands of deaths worldwide every year especially in developing countries, where nutrition and health care are not optimal.

**What it does:**

When your child receives this vaccine, his/her immune system (the body's natural defence) will make antibodies that will recognize the most commonly occurring types of rotavirus. These antibodies protect against disease caused by these types of rotavirus and will protect your child from infection.

As with all vaccines, ROTARIX may not completely protect all children who are vaccinated.

**When it should not be used:**

ROTARIX should not be used if your child:

- has previously had any allergic reaction to rotavirus vaccines or any component contained in ROTARIX (the active substance and other ingredients in ROTARIX; see "What the medicinal ingredient is" and "What the important non-medicinal ingredients are" sections). Signs of an allergic reaction may include itchy skin rash, shortness of breath and swelling of the face or tongue
- has ever had intussusception or was born with a malformation of the gastrointestinal system that would

predispose for intussusception (a bowel obstruction in which one segment of bowel becomes enfolded within another segment)

- if your child has a rare inherited illness which affects their immune system called Severe Combined Immunodeficiency (SCID)

**Take special care with ROTARIX:**

Excretion of the live vaccine virus in the stools of vaccinated children is known to occur after vaccination, especially around the 7<sup>th</sup> day. Persons in contact with recent vaccinated children should wash their hands after changing the child's diapers.

ROTARIX should be given with caution to children in close contact with individuals having any disease or receiving any medicine which may reduce his/her resistance to infection.

**What the medicinal ingredient is:**

ROTARIX consists of live, attenuated human rotavirus.

**What the important nonmedicinal ingredients are:**

The important nonmedical ingredients are Dulbecco's Modified Eagle Medium (DMEM), sucrose, di-sodium adipate, and sterile water.

The vaccine contains small fragments from porcine circovirus type 1 (a virus that infects pigs). This virus is not known to cause illness in humans or any other animal.

**What dosage forms it comes in:**

The ROTARIX vaccine is a suspension for oral administration.

**WARNINGS AND PRECAUTIONS**

BEFORE you use ROTARIX talk to your doctor or pharmacist if your child:

- suffers from disorders of the stomach or intestines
- has an intolerance to some sugars (see "What the important nonmedicinal ingredients are")
- has any disease or is taking any medicine which reduces his/her resistance to infection
- has a severe infection with a high temperature. It might be necessary to postpone the vaccination until recovery. A minor infection such as a cold should not be a problem, but talk to your doctor first.
- has diarrhea or is vomiting. It might be necessary to postpone the vaccination until recovery.

## INTERACTIONS WITH THIS VACCINE

Please tell your doctor if your child is taking or has recently taken any other medicines, including medicines obtained without a prescription, or has recently received any other vaccine.

ROTARIX may be given at the same time your child receives other normally recommended vaccinations, such as diphtheria, tetanus, pertussis (whooping cough), *Haemophilus influenzae* type b, inactivated polio, hepatitis B, pneumococcal vaccines as well as meningococcal serogroup C conjugate vaccine.

## PROPER USE OF THIS VACCINE

### Usual dose:

The Health Care provider will administer the recommended dose of ROTARIX to your child. The vaccine (1.5 mL liquid) will be given orally. **Under no circumstance should this vaccine be administered by injection.**

Your child will receive two doses of the vaccine. Each dose will be given on a separate occasion with an interval of at least 4 weeks between the two doses. The first dose may be given from the age of 6 weeks. The two doses of the vaccine must have been given by the age of 24 weeks, although they should preferably have been given before 16 weeks of age. ROTARIX may be given to infants who were born prematurely following the same vaccination course.

Your doctor may suggest giving the ROTARIX vaccine during the 2 and 4 month visits when getting some of the other vaccines.

In case your child spits out or regurgitates most of the vaccine dose, a single replacement dose may be given at the same vaccination visit.

There are no restrictions on the infant's consumption of food or liquid, including breastmilk, either before or after the vaccination.

When ROTARIX is given to your child for the first dose, it is recommended that your child also receives ROTARIX (and not another rotavirus vaccine) for the second dose.

### Overdose:

Some cases of overdose have been reported. In general, the side effects reported are similar to those seen after administration of the recommended dose of ROTARIX.

In case of drug overdose, contact a health care practitioner, hospital emergency department or regional Poison Control Centre immediately, even if there are no symptoms.

### Missed Dose:

It is important that you follow the instructions of your Health Care Provider regarding return visits. If you forget to go back to your doctor at the scheduled time, ask your doctor for advice.

## SIDE EFFECTS AND WHAT TO DO ABOUT THEM

Like all medicines, ROTARIX can cause side effects, although not everybody gets them. Side effects that occurred during clinical trials with ROTARIX were as follows:

Common (side effects which may occur between 1% and 10% of doses):

- diarrhea
- irritability

Uncommon (side effects which may occur between 0.1% and 1% of doses):

- abdominal pain (see also below for signs of very rare side effects of intussusception)
- dermatitis
- flatulence

Side effects that occurred during routine use of ROTARIX include:

Rare:

- blood in stools
- children with a rare inherited illness called Severe Combined Immunodeficiency (SCID) may have an inflamed stomach or gut (gastroenteritis) and pass the vaccine virus in their stools. The signs of gastroenteritis may include feeling sick, being sick, stomach cramps or diarrhea.

Very rare:

- intussusception (part of the intestine gets blocked or twisted). The signs may include severe stomach pain, persistent vomiting, blood in stools, a swollen belly and/or high fever. **Contact a doctor/health care professional right away if your child experiences one of these symptoms.**



Contact your doctor right away if your child experiences any of the above rare side effects.

*This is not a complete list of side effects. For any unexpected effects while taking ROTARIX, contact your doctor or pharmacist.*

### HOW TO STORE IT

- Keep out of reach and sight of children.
- Store in a refrigerator (2°C to 8°C).
- Do not freeze.
- Store in original package to protect from light.

### REPORTING SUSPECTED SIDE EFFECTS

To monitor vaccine safety, the Public Health Agency of Canada collects case reports on adverse events following immunization.

#### For health care professionals:

If a patient experiences an adverse event following immunization, please complete the appropriate Adverse Events following Immunization (AEFI) Form and send it to your local Health Unit in [your province/territory](#).

#### For the General Public:

Should you experience an adverse event following immunization, please ask your doctor, nurse, or pharmacist to complete the Adverse Events following Immunization (AEFI) Form.

If you have any questions or have difficulties contacting your local health unit, please contact Vaccine Safety Section at Public Health Agency of Canada:

By toll-free telephone: 1-866-844-0018

By toll-free fax: 1-866-844-5931

By email: [caefi@phac-aspc.gc.ca](mailto:caefi@phac-aspc.gc.ca)

At the following website:

<http://www.phac-aspc.gc.ca/im/vs-sv/index-eng.php>

By regular mail:

The Public Health Agency of Canada

Vaccine Safety Section

130 Colonnade Road

Ottawa, Ontario

K1A 0K9 Address Locator 6502A

**NOTE:** Should you require information related to the management of the side effect, please contact your health care provider before notifying the Public Health Agency of Canada. The Public Health Agency of Canada does not provide medical advice.

### MORE INFORMATION

This document plus the full product monograph, prepared for health professionals can be found at:

<http://www.gsk.ca>

or by contacting the sponsor, GlaxoSmithKline Inc.  
7333 Mississauga Road  
Mississauga, Ontario L5N 6L4

1-800-387-7374

This leaflet was prepared by GlaxoSmithKline Inc.  
Last revised: June 11, 2018

©2018 GSK group of companies or its licensor  
Trademarks are owned by or licensed to the GSK group of companies