

PRODUCT MONOGRAPH  
INCLUDING PATIENT MEDICATION INFORMATION

**Pr pdp-AMLODIPINE**

Amlodipine besylate oral solution

Solution, 1 mg/mL amlodipine (as amlodipine besylate), Oral

Antihypertensive-Antianginal Agent

PENDOPHARM, Division of Pharmascience Inc.  
6111 Royalmount Ave., Suite 100  
Montréal, Québec  
H4P 2T4

Date of Initial Approval:  
January 11, 2019

[www.pendopharm.com](http://www.pendopharm.com)

Submission Control No: 211854

## TABLE OF CONTENTS

<b>PART I: HEALTH PROFESSIONAL INFORMATION</b> .....	<b>3</b>
<b>1 INDICATIONS</b> .....	<b>3</b>
1.1 Pediatrics.....	3
1.2 Geriatrics.....	3
<b>2 CONTRAINDICATIONS</b> .....	<b>3</b>
<b>3 DOSAGE AND ADMINISTRATION</b> .....	<b>4</b>
3.1 Dosing Considerations .....	4
3.2 Recommended Dose and Dosage Adjustment .....	4
3.3 Administration.....	5
3.4 Missed Dose.....	5
<b>4 OVERDOSAGE</b> .....	<b>5</b>
<b>5 DOSAGE FORMS, STRENGTHS, COMPOSITION AND PACKAGING</b> .....	<b>6</b>
<b>6 WARNINGS AND PRECAUTIONS</b> .....	<b>7</b>
6.1 Special Populations.....	8
6.1.1 Pregnant Women.....	8
6.1.2 Breast-feeding .....	8
6.1.3 Pediatrics.....	9
6.1.4 Geriatrics .....	9
<b>7 ADVERSE REACTIONS</b> .....	<b>9</b>
7.1 Adverse Reaction Overview .....	9
7.2 Clinical Trial Adverse Reactions.....	9
7.3 Less Common Clinical Trial Adverse Reactions .....	10
7.4 Post-Market Adverse Reactions.....	11
<b>8 DRUG INTERACTIONS</b> .....	<b>11</b>
8.1 Overview .....	11
8.2 Drug-Drug Interactions .....	12
8.3 Drug-Food Interactions.....	15
8.4 Drug-Herb Interactions .....	16
<b>9 ACTION AND CLINICAL PHARMACOLOGY</b> .....	<b>16</b>
9.1 Mechanism of Action .....	16
9.2 Pharmacodynamics.....	16
9.3 Pharmacokinetics .....	17
<b>10 STORAGE, STABILITY AND DISPOSAL</b> .....	<b>19</b>
<b>PART II: SCIENTIFIC INFORMATION</b> .....	<b>20</b>
<b>11 PHARMACEUTICAL INFORMATION</b> .....	<b>20</b>
<b>12 CLINICAL TRIALS</b> .....	<b>21</b>
12.1 Comparative Bioavailability Studies.....	21
<b>13 NON-CLINICAL TOXICOLOGY</b> .....	<b>22</b>
<b>14 SUPPORTING PRODUCT MONOGRAPHS</b> .....	<b>28</b>
<b>PATIENT MEDICATION INFORMATION</b> .....	<b>29</b>

## PART I: HEALTH PROFESSIONAL INFORMATION

### 1 INDICATIONS

pdp-AMLODIPINE (amlodipine besylate) is indicated for the:

- Treatment of mild to moderate essential hypertension.

Combination of pdp-AMLODIPINE with a diuretic, a beta-blocking agent, or an angiotensin converting enzyme inhibitor has been found to be compatible and showed additive antihypertensive effect.

- Management of chronic stable angina (effort-associated angina) in patients who remain symptomatic despite adequate doses of beta-blockers and/or organic nitrates or who cannot tolerate those agents.

pdp-AMLODIPINE may be tried in combination with beta-blockers in chronic stable angina in patients with normal ventricular function. When such concomitant therapy is introduced, care must be taken to monitor blood pressure closely since hypotension can occur from the combined effects of the drugs.

#### 1.1 Pediatrics

**Pediatrics (6-17 years of age):** Based on the data submitted and reviewed by Health Canada, the safety and efficacy of amlodipine, for the treatment of hypertension, in pediatric patients aged 6-17 years, has been established; therefore, Health Canada has authorized an indication for pediatric use. Dosing and safety considerations are to be taken into account when prescribing pdp-AMLODIPINE in this patient population (See **DOSAGE AND ADMINISTRATION; WARNINGS AND PRECAUTIONS;** and **ACTION AND CLINICAL PHARMACOLOGY**).

The use of pdp-AMLODIPINE in children less than 6 years of age is not recommended (See **WARNINGS AND PRECAUTIONS, Special Populations**).

#### 1.2 Geriatrics

**Geriatrics (≥ 65 years of age):** Evidence from clinical studies suggests that use in the geriatric population is associated with differences in safety and exposure (See **DOSAGE AND ADMINISTRATION; WARNINGS AND PRECAUTIONS;** and **ACTION AND CLINICAL PHARMACOLOGY**).

### 2 CONTRAINDICATIONS

pdp-AMLODIPINE is contraindicated in patients:

- Who are hypersensitive to this drug or to any ingredient in the formulation, including any

non-medicinal ingredient, or component of the container. For a complete listing, see **DOSAGE FORMS, STRENGTHS, COMPOSITION AND PACKAGING**.

- With hypersensitivity to other dihydropyridines\* (See **DRUG INTERACTIONS**). (\*amlodipine besylate is a dihydropyridine calcium channel blocker.)
- With severe hypotension (less than 90 mmHg systolic). (See **WARNINGS AND PRECAUTIONS, Cardiovascular**.)
- Who are nursing women, as amlodipine is transferred into human breast milk (See **WARNINGS AND PRECAUTIONS**).
- With hereditary fructose intolerance (See **WARNINGS AND PRECAUTIONS**).
- With hyperglycerolemia or glycerol kinase deficiency (See **WARNINGS AND PRECAUTIONS, General, Effects of Glycerol Intake**).

### **3 DOSAGE AND ADMINISTRATION**

#### **3.1 Dosing Considerations**

Dosing should be individualized depending on patient's tolerance and responsiveness.

The following aspects should be considered when developing a dosage regimen of pdp-AMLODIPINE in an individual patient:

- Elderly patients ( $\geq 65$  years of age)
- Renal impairment
- Hepatic impairment
- Pediatric patients from 6-17 years old

#### **3.2 Recommended Dose and Dosage Adjustment**

For both hypertension and angina, the recommended initial dose of pdp-AMLODIPINE (amlodipine besylate) is 5 mg (5 mL) once daily. If necessary, dose can be increased after 1-2 weeks to a maximum of 10 mg (10 mL) once daily.

**Geriatrics ( $\geq 65$  years of age):** The recommended initial dose in patients over 65 years of age is 5 mg (5 mL) once daily. If required, increasing in the dose should be done gradually and with caution (See **WARNINGS AND PRECAUTIONS**).

**Patients with Impaired Renal Function:** The recommended initial dose in patients with impaired renal function is 5 mg (5 mL) once daily. If required, increasing in the dose should be done gradually and with caution (See **ACTION AND CLINICAL PHARMACOLOGY, Pharmacokinetics, Special Populations and Conditions**).

**Patients with Impaired Hepatic Function:** Dosage requirements have not been established in patients with impaired hepatic function (mild, moderate or severe). When pdp-AMLODIPINE is used in these patients, the dosage should be carefully and gradually adjusted depending on the patient's tolerance and response. A lower starting dose of 2.5 mg (2.5 mL) once daily should be considered (See **WARNINGS AND PRECAUTIONS, Hepatic/Biliary/Pancreatic**).

**Pediatric Patients (6-17 years of age):** The effective antihypertensive oral dose in pediatric patients aged 6-17 years is 2.5 mg (2.5 mL) to 5 mg (5 mL) once daily. Doses in excess of 5 mg (5 mL) daily have not been studied; dose should be determined based upon the medical need of the patients. In children, gender differences in blood pressure response to amlodipine have been observed (See **WARNINGS AND PRECAUTIONS** and **ACTION AND CLINICAL PHARMACOLOGY**).

### 3.3 Administration

pdp-AMLODIPINE is for oral administration.

This product should **not** be shaken prior to administration.

This product should be taken at the same time every day (e.g., with breakfast, lunch or at bedtime), but it should **not** be mixed with food or beverages before use.

### 3.4 Missed Dose

If a dose is missed, it should be taken as soon as the patient remembers. If it has been more than 12 hours since the last dose, the missed dose should be skipped and the next dose can be continued at the regular time. Double doses should not be taken.

## 4 OVERDOSAGE

**Signs and Symptoms:** Overdosage can cause excessive peripheral vasodilation with marked and probably prolonged hypotension and possibly a reflex tachycardia. In humans, experience with overdosage of amlodipine besylate is limited.

### Reports of Overdose in Adult Patients

- When amlodipine was ingested at doses of 105-250 mg, some patients remained normotensive with or without gastric lavage while another patient experienced hypotension (90/50 mmHg) which normalized following plasma expansion.
- A patient who took 70 mg amlodipine with benzodiazepine developed shock, which was refractory to treatment, and died.

### Reports of Overdose in Pediatric Patients

- In a 19-month-old child who ingested 30 mg amlodipine (about 2 mg/kg), there was no evidence of hypotension, but tachycardia (180 bpm) was observed. Ipecac was administered 3.5 hours after ingestion and on subsequent observation (overnight), no sequelae were noted.
- A 15-year-old girl intentionally ingested 140 mg amlodipine along with 10 capsules of mefenamic acid, which resulted in hypotension, tachycardia, labored breathing, cardiac arrest and death, 6 hours after ingestion. Post-mortem peripheral blood levels of amlodipine were found to be 2.7 mg/L.
- Ingestion of amlodipine with fatal outcome was reported in an 11-month-old boy (11 kg) who ingested 10 to 45 mg amlodipine with 40 to 180 mg benazepril. Forty-five minutes post-ingestion, the child was suddenly unresponsive. Upon arrival at an emergency facility, the child presented with cardiovascular collapse and abnormal laboratory values for HCO<sub>3</sub> (13 mmol/L) and glucose (302 mg/dL). The post-mortem amlodipine heart blood level was

1,300 mg/L. The report authors commented that small doses of amlodipine (0.9 to 4.1 mg/kg) may produce rapid and fatal cardiovascular collapse in an infant.

- An 11-month-old boy (6 kg) received 6 doses of 15 mg amlodipine due to a medication error. He presented with vomiting, lethargy, breathlessness, progressive loss of consciousness, muffled heart sounds and progressed to hypotensive shock. The patient also had hepatomegaly and blood sugar of 382 mg/dL. He received mechanical ventilation, fluid therapy with normal saline and inotropes, but his parameters improved rapidly only after initiating insulin and dextrose infusion therapy (for 15 h) along with glucagon and calcium gluconate infusion (for 72 h). The report authors commented that clinical presentation of CCB overdose (hypotension, dysrhythmia, and hyperglycemia) in children may occur with doses as low as 2.5 mg and these symptoms are dose dependent, especially when the ingested dose is 10 mg or more.

**Treatment:** Clinically significant hypotension due to overdosage requires active cardiovascular support including frequent monitoring of cardiac and respiratory function, elevation of extremities, and attention to circulating fluid volume and urine output. A vasoconstrictor (such as norepinephrine) may be helpful in restoring vascular tone and blood pressure, provided that there is no contraindication to its use. As pdp-AMLODIPINE is highly protein bound, hemodialysis is not likely to be of benefit. Intravenous calcium gluconate may be beneficial in reversing the effects of calcium channel blockade. Clearance of amlodipine is prolonged in elderly patients and in patients with impaired liver function. Since amlodipine absorption is slow, gastric lavage may be worthwhile in some cases.

In an amlodipine poisoning case reported in an 11-month-old infant with blood glucose of 382 mg/dL, high-dose insulin infusion at 0.5 u/kg/h with intravenous 25 % dextrose, intramuscular glucagon (for maintaining euglycemia) and continuous infusion of calcium gluconate (0.5 mEq/kg/h) after initiation of vasopressors, were found to be beneficial and to result in normalization of blood pressure and peripheral pulses. The patient also had renal failure, oliguria, congestive cardiac failure and pulmonary edema, which were managed through peritoneal dialysis initiated at 24 h of admission. These interventions were successful in managing this case of amlodipine poisoning.

For management of a suspected drug overdose, contact your regional poison control centre.

## 5 DOSAGE FORMS, STRENGTHS, COMPOSITION AND PACKAGING

Route of Administration	Dosage Form / Strength/Composition	Non-medicinal Ingredients
Oral	1 mg/mL amlodipine (as amlodipine besylate)	glycerol, liquid maltitol, purified water

Bottle: Amber (Type III glass)

Closure: HDPE, EPE wadded, child resistant closure

Dosing Device: Polypropylene body, purple HDPE plunger with a capacity of 5 mL and dosage graduation at every 0.25 mL

Bottle Adaptor: Low density polyethylene

Pack size: 150 mL

## 6 WARNINGS AND PRECAUTIONS

### General

**Beta-blocker Withdrawal:** pdp-AMLODIPINE (amlodipine besylate) gives no protection against the dangers of abrupt beta-blocker withdrawal and such withdrawal should be done by the gradual reduction of the dose of beta-blocker.

**Peripheral Edema:** Mild to moderate peripheral edema was the most common adverse event in the clinical trials (See **ADVERSE REACTIONS**). The incidence of peripheral edema was dose-dependent and ranged in frequency from 3.0 to 10.8% in 5 to 10 mg dose range. Care should be taken to differentiate this peripheral edema from the effects of increasing left ventricular dysfunction.

**Concomitant Use with Strong Inhibitors of CYP 3A4:** Use of pdp-AMLODIPINE with drugs that result in strong inhibition of CYP 3A4, such as ketoconazole, clarithromycin, ritonavir, may lead to increased plasma levels of amlodipine and associated serious events (See **DRUG INTERACTIONS**). Such concomitant use should be avoided.

An observational study demonstrated an increased risk of hospitalization with acute kidney injury when amlodipine was used concomitantly with clarithromycin in elderly patients (>65 years of age) compared to when it was used concomitantly with azithromycin [odds ratio, amlodipine: 1.61 (95% C.I. 1.29--2.02)]. (See **DRUG INTERACTIONS**).

**Effects of Glycerol Intake:** Glycerol is a non-medicinal ingredient used in the pdp-AMLODIPINE oral solution formulation. Before initiating treatment with pdp-AMLODIPINE, the patient should be informed that this drug contains glycerol which may cause gastro-intestinal discomfort, laxative effects and headaches in some patients, particularly in children.

The use of pdp-AMLODIPINE is contraindicated in patients with hyperglycerolemia or glycerol kinase deficiency (See **CONTRAINDICATIONS**).

### Cardiovascular

**Increased Angina and/or Myocardial Infarction:** Rarely, patients, particularly those with severe obstructive coronary artery disease, have developed documented increased frequency, duration and/or severity of angina or acute myocardial infarction on starting calcium channel blocker therapy or at the time of dosage increase. The mechanism of this effect has not been elucidated (See **ADVERSE REACTIONS**).

**Outflow Obstruction (Aortic Stenosis):** pdp-AMLODIPINE should be used with caution in a presence of fixed left ventricular outflow obstruction (aortic stenosis).

**Patients with Congestive Heart Failure:** Although generally calcium channel blockers should only be used with caution in patients with heart failure, it has been observed that amlodipine had no overall deleterious effect on survival and cardiovascular morbidity in both short-term

and long-term clinical trials in these patients. While a significant proportion of the patients in these studies had a history of ischemic heart disease, angina or hypertension, the studies were not designed to evaluate the treatment of angina or hypertension in patients with concomitant heart failure (See **ADVERSE REACTIONS**).

**Hypotension:** pdp-AMLODIPINE may occasionally precipitate symptomatic hypotension. Careful monitoring of blood pressure is recommended, especially in patients with a history of cerebrovascular insufficiency, and those taking medications known to lower blood pressure (See **CONTRAINDICATIONS**).

## **Gastrointestinal**

**Patients with Hereditary Fructose Intolerance:** Due to the presence of maltitol liquid in the product formulation, the use of pdp-AMLODIPINE in patients with hereditary problems of fructose intolerance is contraindicated (See **CONTRAINDICATIONS**).

## **Hepatic / Biliary / Pancreatic**

**Patients with Mild to Moderate Hepatic Impairment:** There are no adequate studies in patients with liver dysfunction and dosage recommendations have not been established. In a small number of patients with mild to moderate hepatic impairment given single dose of 5 mg, amlodipine half-life has been prolonged (See **ACTION AND CLINICAL PHARMACOLOGY, Pharmacokinetics**). pdp-AMLODIPINE should, therefore, be administered with caution in these patients and careful monitoring should be performed. A lower starting dose may be required (See **DOSAGE AND ADMINISTRATION**).

**Patients with Severe Hepatic Impairment or Hepatic Failure:** Because pdp-AMLODIPINE is extensively metabolized by the liver and the plasma elimination half-life ( $t_{1/2}$ ) is 56 hours in patients with impaired hepatic function, it should be administered cautiously and at reduced dosages in patients with severely impaired hepatic function (See **DOSAGE AND ADMINISTRATION, Recommended Dose and Dosage Adjustment**). Slow dose titration and careful monitoring are required in patients with severe hepatic impairment.

## **6.1 Special Populations**

### **6.1.1 Pregnant Women**

Although amlodipine was not teratogenic in the rat and rabbit, some dihydropyridine compounds have been found to be teratogenic in animals. In rats, amlodipine has been shown to prolong the gestation period and the duration of labor. There was no effect on the fertility of rats treated with amlodipine (See **NON-CLINICAL TOXICOLOGY, Reproductive and Developmental Toxicology**). There is no clinical experience with pdp-AMLODIPINE in pregnant women. pdp-AMLODIPINE should be used during pregnancy only if the potential benefit outweighs the potential risk to the mother and fetus.

### **6.1.2 Breast-feeding**

In a human study, the mean maternal daily dose of amlodipine was 6.0 mg and the medians of the plasma and milk concentrations of amlodipine were 15.5 and 11.5 ng/mL, respectively, with median milk/plasma concentration ratio of 0.85. Since amlodipine safety in newborns has not



been established, pdp-AMLODIPINE is contraindicated in nursing mothers. A decision should be made whether to discontinue nursing or discontinue the drug, taking into account the importance of the drug to the mother (See **CONTRAINDICATIONS**).

### 6.1.3 Pediatrics

The use of pdp-AMLODIPINE is not recommended in patients less than 6 years of age since safety and efficacy have not been established in that population (See **INDICATIONS**).

In pediatric patients aged 6-17 years, safety and efficacy studies beyond 8 weeks of duration, for the treatment of hypertension, have not been conducted (See **ACTION AND CLINICAL PHARMACOLOGY**). Moreover, the long-term effects of amlodipine on growth, puberty and general development have not been studied. The prescription in this population should be based on a careful risk/benefit assessment of the limited available information. The risk/benefit assessment should be conducted by a qualified physician.

### 6.1.4 Geriatrics

In elderly patients ( $\geq 65$  years) clearance of amlodipine is decreased with a resulting increase in AUC (See **ACTION AND CLINICAL PHARMACOLOGY, Pharmacokinetics**). In clinical trials, the incidence of adverse reactions in elderly patients was approximately 6% higher than that of younger population ( $< 65$  years). Adverse reactions include edema, muscle cramps, and dizziness. pdp-AMLODIPINE should be used cautiously in elderly patients. Dosage adjustment is advisable (See **INDICATIONS** and **DOSAGE AND ADMINISTRATION**).

## 7 ADVERSE REACTIONS

### 7.1 Adverse Reaction Overview

Amlodipine besylate has been administered to 1,714 patients (805 hypertensive and 909 angina patients) in controlled clinical trials (vs placebo alone and with active comparative agents). Most adverse reactions reported during therapy were of mild to moderate severity.

### 7.2 Clinical Trial Adverse Reactions

Because clinical trials are conducted under very specific conditions, the adverse reaction rates observed in the clinical trials may not reflect the rates observed in practice and should not be compared to the rates in the clinical trials of another drug. Adverse reaction information from clinical trials is useful for identifying drug-related adverse events and for approximating rates.

#### HYPERTENSION

In the 805 hypertensive patients treated with amlodipine in controlled clinical trials, adverse effects were reported in 29.9% of patients and required discontinuation of therapy due to side effects in 1.9% of patients. The most common adverse reactions in controlled clinical trials were: oedema (8.9%), and headache (8.3%).

The following adverse reactions were reported with an incidence of  $\geq 0.5\%$  in the controlled clinical trials program (n=805):

**Cardiovascular:** oedema (8.9%), palpitations (2.0%), tachycardia (0.7%), postural dizziness

(0.5%).

**Skin and Appendages:** pruritus (0.7%).

**Musculoskeletal:** muscle cramps (0.5%).

**Central and Peripheral Nervous System:** headaches (8.3%), dizziness (3.0%), paraesthesia (0.5%).

**Autonomic Nervous System:** flushing (3.1%), hyperhidrosis (0.9%), dry mouth (0.7%).

**Psychiatric:** somnolence (1.4%).

**Gastrointestinal:** nausea (2.4%), abdominal pain (1.1%), dyspepsia (0.6%), constipation (0.5%).

**General:** fatigue (4.1%), pain (0.5%).

### ANGINA

In the controlled clinical trials in 909 angina patients treated with amlodipine, adverse effects were reported in 30.5% of patients and required discontinuation of therapy due to side effects in 0.6% of patients. The most common adverse reactions reported in controlled clinical trials were: oedema (9.9%) and headache (7.8%).

The following adverse reactions occurred at an incidence of  $\geq 0.5\%$  in the controlled clinical trials program (n=909);

**Cardiovascular:** oedema (9.9%), palpitations (2.0%), postural dizziness (0.6%).

**Skin and Appendages:** rash (1.0%), pruritus (0.8%).

**Musculoskeletal:** muscle cramps (1.0%).

**Central and Peripheral Nervous System:** headaches (7.8%), dizziness (4.5%), paraesthesia (1.0%), hypoesthesia (0.9%).

**Autonomic Nervous System:** flushing (1.9%).

**Psychiatric:** somnolence (1.2%), insomnia (0.9%), nervousness (0.7%).

**Gastrointestinal:** nausea (4.2%), abdominal pain (2.2%), dyspepsia (1.4%), diarrhea (1.1%), flatulence (1.0%), constipation (0.9%).

**Respiratory System:** dyspnea (1.1%).

**Special Senses:** visual impairment (1.3%), tinnitus (0.6%).

**General:** fatigue (4.8%), pain (1.0%), asthenia (1.0%).

### **7.3 Less Common Clinical Trial Adverse Reactions**

Amlodipine besylate has been evaluated for safety in about 11,000 patients with hypertension and angina. The following events occurred in  $<1\%$  but  $>0.1\%$  of patients in comparative clinical trials (double-blind comparative vs placebo or active agents; n = 2,615) or under conditions of open trials or marketing experience where a causal relationship is uncertain.

**Autonomic Nervous System:** dry mouth, hyperhidrosis.

**Cardiovascular:** arrhythmia (including ventricular tachycardia and atrial fibrillation), bradycardia, myocardial infarction, hypotension, peripheral ischemia, syncope, tachycardia, postural dizziness, postural hypotension, vasculitis, chest pain.

**Central and Peripheral Nervous System:** hypoesthesia/paraesthesia, neuropathy peripheral, tremor, vertigo.

**Gastrointestinal:** anorexia, constipation, dysphagia, vomiting, gingival hyperplasia, change in bowel habits, dyspepsia

**General:** allergic reaction, asthenia<sup>+</sup>, back pain, pain, hot flushes, malaise, rigors, and weight increased/weight decreased.

**Hemopoietic:** leukopenia, purpura, thrombocytopenia.

**Metabolic and Nutritional:** hyperglycemia, thirst.

**Musculoskeletal System:** arthralgia, arthrosis, myalgia, muscle cramps.

**Psychiatric:** sexual dysfunction (male<sup>+</sup> and female), insomnia, nervousness, depression, abnormal dreams, anxiety, depersonalization, mood altered.

**Respiratory System:** dyspnea, epistaxis.

**Skin and Appendages:** pruritus, rash erythematous, rash maculopapular, erythema multiforme.

**Special Senses:** conjunctivitis, diplopia, eye pain, visual impairment, tinnitus.

**Urinary System:** pollakiuria, micturition disorder, nocturia.

**Reproductive system and breast disorders:** gynecomastia, erectile dysfunction.

<sup>+</sup> These events occurred in less than 1% in placebo controlled trials, but the incidence of these side effects was between 1% and 2% in all multiple dose studies.

The following events occurred in  $\leq 0.1\%$  of patients: cardiac failure, skin discoloration\*, urticaria\*, skin dryness, Stevens-Johnson syndrome, alopecia\*, twitching, ataxia, hypertonia\*, migraine, apathy, amnesia, gastritis\*, pancreatitis\*, increased appetite, coughing\*, rhinitis\*, parosmia, taste perversion\*, and xerophthalmia.

\* These events were observed in marketing experience as well.

Isolated cases of angioedema have been reported. Angioedema may be accompanied by breathing difficulty.

## 7.4 Post-Market Adverse Reactions

In post-marketing experience, jaundice and hepatic enzyme elevations (mostly consistent with cholestasis or hepatitis) in some cases severe enough to require hospitalization have been reported in association with use of amlodipine.

Post-marketing reporting has also revealed cases of extrapyramidal disorders induced by amlodipine.

## 8 DRUG INTERACTIONS

### 8.1 Overview

As with all drugs, care should be exercised when treating patients with multiple medications. Dihydropyridine calcium channel blockers undergo biotransformation by the cytochrome P450 system, mainly via CYP 3A4 isoenzyme. Co-administration of amlodipine with other drugs which follow the same route of biotransformation may result in altered bioavailability of amlodipine or these drugs. Dosages of similarly metabolized drugs, particularly those of low therapeutic ratio, especially in patients with renal and/or hepatic impairment, may require adjustment when starting or stopping concomitantly administered amlodipine to maintain optimum therapeutic blood levels.

## 8.2 Drug-Drug Interactions

The drugs listed in this table are based on either drug interaction case reports or studies, or potential interactions due to the expected magnitude and seriousness of the interaction (i.e., those identified as contraindicated).

**Table 1 - Established or Potential Drug-Drug Interactions**

Common name	Source of Evidence	Effect	Clinical comment
Drugs known to be inhibitors of the cytochrome P450 system (diltiazem, azole antifungals, erythromycin, quinidine, terfenadine and warfarin)	CT T	Co-administration of a 180-mg daily dose of diltiazem with 5 mg amlodipine in elderly hypertensive patients (69 to 87 years of age) resulted in a 57% increase in amlodipine systemic exposure.  Erythromycin co-administration in healthy volunteers (18 to 43 years of age) increased the systemic exposure of amlodipine by 22%.	These pharmacokinetic changes may be more pronounced in the elderly. Close monitoring and dose adjustment may be required.
Strong inhibitors of CYP3A4 (e.g., ketoconazole, itraconazole, ritonavir, clarithromycin)	T	May significantly increase the plasma concentrations of amlodipine to a greater extent than diltiazem.	Amlodipine should be used with caution together with CYP3A4 inhibitors and monitoring of therapy is required. Appropriate dosage adjustment of amlodipine may be necessary when used with CYP3A4 inhibitors. Patients should be advised to seek medical attention if they experience edema or swelling of the lower extremities; sudden, unexplained weight gain; difficulty breathing; chest pain or tightness; or hypotension as indicated by dizziness, fainting, or orthostasis.  Avoid concomitant administration of amlodipine with strong CYP3A4 inhibitors.

Clarithromycin	CT	In elderly patients (>65 years of age), concomitant use of amlodipine with clarithromycin was associated with increased risk of hospitalization with acute kidney injury.	Avoid concomitant use.
Drugs known to be inducers of the cytochrome P450 system include: phenobarbital, phenytoin, rifampin	T	There is no data available regarding the effect of CYP3A4 inducers on amlodipine. The concomitant use of CYP3A4 inducers may give a lower plasma concentration of amlodipine which in turn can result in decreased blood pressure lowering effects.	Amlodipine should be used with caution together with CYP3A4 inducers and dose adjustment may be necessary to maintain efficacy. Hence, monitoring of therapy is required.
Drugs known to be biotransformed via P450 (benzodiazepines, flecainide, imipramine, propafenone, theophylline)	T	Amlodipine has a low (rate of first-pass) hepatic clearance and consequent high bioavailability, and thus, may be expected to have a low potential for clinically relevant effects associated with elevation of amlodipine plasma levels when used concomitantly with drugs that compete for or inhibit the cytochrome P450 system.	
Cimetidine, warfarin, digoxin	CT	Pharmacokinetic interaction studies with amlodipine in healthy volunteers have indicated that cimetidine did not alter the pharmacokinetics of amlodipine and that amlodipine did not change warfarin-induced prothrombin response time nor did it change serum digoxin levels or digoxin renal clearance in normal volunteers.	

Antacids	CT	Concomitant administration of Maalox <sup>®</sup> (magnesium hydroxide and aluminum hydroxide) had no effect on the disposition of a single 5 mg dose of amlodipine in 24 subjects.	
Beta-blockers	T	Blood pressure lowering effect of beta-blockers may be increased by amlodipine.	When beta-adrenergic receptor blocking drugs are administered concomitantly with pdp-AMLODIPINE, patients should be carefully monitored since blood pressure lowering effect of beta-blockers may be augmented by amlodipine's reduction in peripheral vascular resistance.
Sildenafil	CT	A single 100 mg dose of sildenafil ( <sup>Pr</sup> Viagra <sup>®</sup> ) in subjects with essential hypertension had no effect on AUC or C <sub>max</sub> of amlodipine. When sildenafil (100 mg) was co-administered with amlodipine, 5 or 10 mg in hypertensive patients, the mean additional reduction of supine blood pressure was 8 mm Hg systolic and 7 mm Hg diastolic.	
Atorvastatin	CT	In healthy volunteers, co-administration of multiple 10 mg doses of pdp-AMLODIPINE with 80 mg of atorvastatin resulted in no clinical significant change in the AUC (average of 18% increase) of C <sub>max</sub> or T <sub>max</sub> of atorvastatin.	Close monitoring is required.
Simvastatin	CT	Co-administration of multiple doses of 10 mg of amlodipine with 80 mg simvastatin resulted in a 77% increase in exposure to simvastatin compared to simvastatin alone.	Limit the dose of simvastatin in patients on amlodipine to 20 mg daily.

Cyclosporin	CT	No drug interaction studies have been conducted with cyclosporin and amlodipine in healthy volunteers or other populations with the exception of renal transplant patients. A prospective study in hypertensive renal transplant patients (N=11) showed on an average of 40% increase in trough cyclosporine levels when concomitantly treated with amlodipine.	Consideration should be given for monitoring cyclosporin levels in renal transplant patients on amlodipine.
Tacrolimus	C	There is a risk of increased tacrolimus blood levels when co-administered with amlodipine.	In order to avoid toxicity of tacrolimus, administration of amlodipine in a patient treated with tacrolimus requires monitoring of tacrolimus blood levels and dose adjustments of tacrolimus when appropriate.
Mechanistic Target of Rapamycin (mTOR) Inhibitors	CT T	mTOR inhibitors such as sirolimus, temsirolimus, and everolimus are CYP3A substrates. Amlodipine is a weak CYP3A inhibitor. With concomitant use of mTOR inhibitors, amlodipine may increase exposure of mTOR inhibitors.	

Legend: C = Case Study; CT = Clinical Trial; T = Theoretical

### 8.3 Drug-Food Interactions

**Interaction with Grapefruit Juice:** Published data indicate that through inhibition of the cytochrome P450 system, grapefruit juice can increase plasma levels and augment pharmacodynamic effects of some dihydropyridine calcium channel blockers. Co-administration of 240 mL of grapefruit juice with a single oral dose of amlodipine 10 mg in 20 healthy volunteers had no significant effect on the pharmacokinetics of amlodipine. The study did not allow examination of the effect of genetic polymorphism in CYP3A4, the primary enzyme responsible for metabolism of amlodipine; therefore, administration of amlodipine with grapefruit or grapefruit juice is not recommended as bioavailability may be increased in some patients resulting in increased blood pressure lowering effects (See **ACTION AND CLINICAL PHARMACOLOGY, Pharmacokinetics**). Hence, monitoring of therapy is required.

## 8.4 Drug-Herb Interactions

St-John's Wort is an inducer of CYP3A4. The concomitant use of CYP3A4 inducers may give a lower plasma concentration of amlodipine which in turn can result in decreased blood pressure lowering effects. Amlodipine should be used with caution together with CYP3A4 inducers and dose adjustment may be necessary to maintain efficacy. Hence, monitoring of therapy is required (See **WARNINGS AND PRECAUTIONS, General**).

## 9 ACTION AND CLINICAL PHARMACOLOGY

### 9.1 Mechanism of Action

pdp-AMLODIPINE (amlodipine besylate) is a calcium ion influx inhibitor (calcium entry blocker or calcium ion antagonist). Amlodipine is a member of the dihydropyridine class of calcium antagonists.

The therapeutic effect of this group of drugs is believed to be related to their specific cellular action of selectively inhibiting transmembrane influx of calcium ions into vascular smooth muscle and cardiac muscle. The contractile processes of these tissues are dependent upon the movement of extracellular calcium ions into these cells through specific ion channels. Amlodipine inhibits calcium ion influx across cell membranes selectively, with a greater effect on vascular smooth muscle cells than on cardiac muscle cells. Serum calcium concentration is not affected by amlodipine. Within the physiologic pH range, amlodipine is an ionized compound and its kinetic interaction with the calcium channel receptor is characterized by the gradual association and dissociation with the receptor binding site. Experimental data suggest that amlodipine binds to both dihydropyridine and nondihydropyridine binding sites.

- A. Hypertension:** The mechanism by which amlodipine reduces arterial blood pressure involves direct peripheral arterial vasodilation and reduction in peripheral vascular resistance.
- B. Angina:** The precise mechanism by which amlodipine relieves angina has not been fully delineated. Amlodipine is a dilator of peripheral arteries and arterioles which reduces the total peripheral resistance and, therefore, reduces the workload of the heart (afterload). The unloading of the heart is thought to decrease ischemia and relieve effort angina by reducing myocardial energy oxygen consumption and oxygen requirements.

### 9.2 Pharmacodynamics

**Hemodynamics:** Following administration of recommended doses to patients with hypertension, amlodipine produces vasodilation resulting in a reduction of supine and standing blood pressures. These decreases in blood pressure are not accompanied by any significant change in heart rate or plasma catecholamine levels with chronic dosing. With chronic once daily oral administration (5 and 10 mg once daily), antihypertensive effectiveness is maintained throughout the 24-hour dose interval with minimal peak to trough differences in plasma concentration. Since the vasodilation induced by amlodipine is gradual in onset, acute hypotension has rarely been reported after oral administration of amlodipine. In normotensive patients with angina, amlodipine has not been associated with any clinically significant reductions in blood pressure or changes in heart rate.



Negative inotropic effects have not been observed when amlodipine was administered at the recommended doses to man, but has been demonstrated in animal models. Hemodynamic measurements of cardiac function at rest and during exercise (or pacing) in angina patients with normal ventricular function have generally demonstrated a small increase in cardiac index without significant influence on dP/dt or on left ventricular end diastolic pressure or volume.

In hypertensive patients with normal renal function, therapeutic doses of amlodipine resulted in a decrease in renal vascular resistance and an increase in glomerular filtration rate and effective renal plasma flow without change in filtration fraction.

**Electrophysiologic Effects:** Amlodipine does not change sinoatrial nodal function or atrioventricular conduction in intact animals, or man. In patients with chronic stable angina, intravenous administration of 10 mg of amlodipine and a further 10 mg of amlodipine after a 30-minute interval, produced peripheral vasodilation and afterload reduction, but did not significantly alter A-H and H-V conduction and sinus node recovery time after pacing. Similar results were obtained in patients receiving amlodipine and concomitant beta-blockers. In clinical studies in which amlodipine was administered in combination with beta-blockers to patients with either hypertension or angina, no adverse effects on electrocardiographic parameters were observed. In clinical trials with angina patients, amlodipine as monotherapy did not alter electrocardiographic intervals.

**Antihypertensive Effect in Pediatric Patients:** Two hundred sixty-eight hypertensive patients aged 6 to 17 years were randomized first to amlodipine 2.5 or 5 mg once daily for 4 weeks and then randomized again to the same dose or to placebo for another 4 weeks. Patients receiving 5 mg at the end of 8 weeks had lower blood pressure than those secondarily randomized to placebo. The magnitude of the treatment effect is difficult to interpret, but it is probably less than 5 mmHg systolic on the 5 mg dose. Adverse events were similar to those seen in adults. Pediatric safety and efficacy studies beyond 8 weeks of duration have not been conducted. In addition, the long-term effect of amlodipine on growth and development, myocardial growth and vascular smooth muscles has not been studied.

### 9.3 Pharmacokinetics

**Absorption:** After oral administration of therapeutic doses of amlodipine, absorption occurs gradually with peak plasma concentration reached between 6 and 12 hours. Absolute bioavailability has been estimated to be between 64 and 90%. The bioavailability of amlodipine is not altered by the presence of food.

**Distribution:** The volume of distribution is approximately 21 L/kg.

**Metabolism:** Amlodipine is metabolized through the cytochrome P450 system, mainly via CYP 3A4 isoenzyme. Amlodipine is extensively (about 90%) converted to inactive metabolites (via hepatic metabolism) with 10% of the parent compound and 60% of the metabolites excreted in the urine. *Ex vivo* studies have shown that approximately 93% of the circulating drug is bound to plasma proteins in hypertensive patients.

**Elimination:** Elimination from the plasma is biphasic with a terminal elimination half-life of about 35-50 hours. Steady state plasma levels of amlodipine are reached after 7 to 8 days of consecutive daily dosing.

## Special Populations and Conditions

Following oral administration of 10 mg amlodipine to 20 male volunteers, pharmacokinetics of amlodipine were: geometric mean  $C_{max}$  of amlodipine was 6.2 ng/mL when the drug was administered with grapefruit juice and 5.8 ng/mL when administered with water. Mean  $T_{max}$  of amlodipine was 7.6 hours with grapefruit juice and 7.9 hours with water. Geometric mean  $AUC_{0-\infty}$  was 315 ng•hr/mL with grapefruit juice and 293 ng•hr/mL with water. Geometric mean bioavailability of amlodipine was 85% when administered with grapefruit juice and 81% when administered with water.

**Pediatrics:** Two studies were conducted to evaluate the use of amlodipine in a pediatric population.

In one pharmacokinetic study, sixty-two hypertensive patients aged greater than 6 years received doses of amlodipine between 1.25 mg and 20 mg. Weight-adjusted clearance and volume of distribution were similar to values in adults. The mean absorption rate constant ( $K_a$ ) in children ( $0.85 \text{ hr}^{-1}$ ) is approximately 50% higher than that in healthy adults ( $0.55 \text{ hr}^{-1}$ , range of  $0.28\text{-}1.09 \text{ hr}^{-1}$ ).

**Sex:** In another clinical trial in children, a pattern of greater reductions in both systolic and diastolic blood pressure in females than in males was observed. Mean change in systolic blood pressure from baseline to end of study: amlodipine 2.5 mg: males, -6.9 mmHg (n=51); females, -8.9 mmHg (n=32); amlodipine 5.0 mg: males, -6.6 mmHg (n=63); females, -14.0 mmHg (n=23); placebo males, -2.5 mmHg (n=54), females, -3.8 mmHg (n=33).

**Geriatrics:** In elderly hypertensive patients (mean age 69 years) there was a decrease in clearance of amlodipine from plasma as compared to young volunteers (mean age 36 years) with a resulting increase in the area under the curve (AUC) of about 60%.

### **Hepatic Insufficiency:**

Patients with mild-moderate hepatic insufficiency: Following single oral administration of 5 mg of amlodipine, patients with chronic mild-moderate hepatic insufficiency showed about 40% increase in AUC of amlodipine as compared to normal volunteers. This was presumably due to a reduction in clearance of amlodipine as the terminal elimination half-life was prolonged from 34 hours in young normal subjects to 56 hours in the elderly patients with hepatic insufficiency function (See **DOSAGE AND ADMINISTRATION, Recommended Dose and Dosage Adjustment**).

Patients with severe hepatic impairment or hepatic failure: Because amlodipine is extensively metabolized by the liver and the plasma elimination half-life ( $t_{1/2}$ ) is 56 hours in patients with impaired hepatic function, it should be administered cautiously and at reduced dosages in patients with severely impaired hepatic function (See **DOSAGE AND ADMINISTRATION, Recommended Dose and Dosage Adjustment**). Slow dose titration and careful monitoring are required in patients with severe hepatic impairment.

**Renal Insufficiency:** The pharmacokinetics of amlodipine are not significantly influenced by renal impairment. Plasma concentrations in the patients with moderate to severe renal failure were higher than in the normal subjects. Accumulation and mean elimination half-life in all patients were within the range of those observed in other pharmacokinetic studies with

amlodipine in normal subjects (See **DOSAGE AND ADMINISTRATION, Recommended Dose and Dosage Adjustment**).

## **10 STORAGE, STABILITY AND DISPOSAL**

Store in a refrigerator (2°C to 8°C). Keep the bottle stored upright. Discard 30 days after opening. Bring unused medication to your local pharmacist for proper disposal.

Keep out of the reach and sight of children.

## PART II: SCIENTIFIC INFORMATION

### 11 PHARMACEUTICAL INFORMATION

#### Drug Substance

Proper/Common name:	amlodipine besylate
Chemical name:	3-Ethyl-5-methyl-2-(2-aminoethoxymethyl)-4-(2-chlorophenyl)-1,4-dihydro-6-methyl-3,5-pyridinedicarboxylate benzenesulphonate
Molecular formula and molecular mass:	$C_{20}H_{25}ClN_2O_5 \cdot C_6H_6O_3S$ and 567.1
Structural formula:	

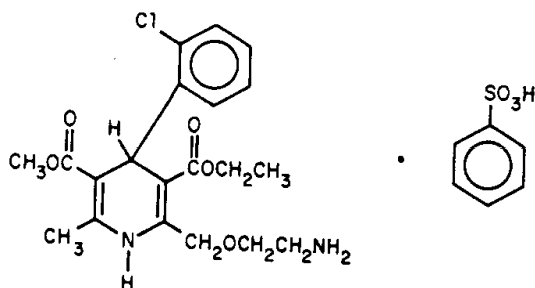

Physicochemical properties:	
Description:	Amlodipine besylate is a white crystalline substance, slightly soluble in water and sparingly soluble in ethanol.
Melting point:	203°C with decomposition.
pKa:	9.02 at 23.5°C

## 12 CLINICAL TRIALS

### 12.1 Comparative Bioavailability Studies

A single centre, randomized, single-dose, open-label, two-way crossover comparative bioavailability study of 1 x 5 mL (10 mg) of AMLODIPINE (amlodipine besylate) 2 mg/mL Oral Solution by Rosemont Pharmaceuticals Ltd., England or 1 x 10 mg of Istin™ (amlodipine besylate) 10 mg tablets of Pfizer Limited, United Kingdom (UK) was conducted in 18 healthy volunteers (12 males and 6 females) under fasting conditions. The results of the 17 subjects (11 males and 6 females) who completed both periods of the study are summarized below. pdp-AMLODIPINE 1 mg/mL Oral Solution is proportionally formulated to the 2 mg/mL strength administered in the comparative bioavailability study.

#### SUMMARY TABLE OF THE COMPARATIVE BIOAVAILABILITY DATA

<b>Amlodipine</b> <b>(10 mg dose administered as either 5 mL x 2 mg/mL Oral Solution or 1 x 10 mg Tablet)</b> <b>From measured data</b>				
<b>Geometric Mean</b> <b>Arithmetic Mean (CV %)</b>				
<b>Parameter</b>	<b>Test*</b>	<b>Reference†</b>	<b>% Ratio of Geometric Means</b>	<b>90% Confidence Interval</b>
AUC <sub>0-72h</sub> (pg•h/mL)	233933.14 242000.72 (26.25)	224925.64 229092.82 (19.37)	103.84	99.50 – 108.38
AUC <sub>1</sub> (pg•h/mL)	321657.16 336094.36 (29.02)	309306.53 316607.40 (21.57)	103.99	98.68 – 109.60
C <sub>max</sub> (pg/mL)	6694.98 7022.12 (32.25)	6527.76 6678.71 (22.08)	102.66	97.06 – 108.58
T <sub>max</sub> <sup>§</sup> (h)	7.00 (5.00 – 16.00)	6.00 (5.00 – 16.00)		
T <sub>½</sub> <sup>#</sup> (h)	37.75 (13.60)	37.88 (14.50)		

\* Amlodipine (amlodipine besylate) Oral Solution, 2 mg/mL by Rosemont Pharmaceuticals Ltd., England

† Istin™ (amlodipine besylate) Tablets, 10 mg by Pfizer Limited UK, purchased in the UK

§ Expressed as median (range) only

# Expressed as the arithmetic mean (CV%) only

### 13 NON-CLINICAL TOXICOLOGY

#### General Toxicology

#### **Acute Toxicity**

Amlodipine (as maleate unless otherwise indicated)

SPECIES	SEX	ROUTE	LD50	Range of Lethal Doses (mg/kg)	
			base/mg/kg	No Deaths	All Dead
Mice	M	p.o.	N.D.	10	40
	F	p.o.	N.D.	10	40
	M	i.v.	N.D.	2.5	10
	F	i.v.	N.D.	2.5	10
Rats	M	p.o.	150	2/10 at 100	400
	F	p.o.	140	2/10 at 100	250
	M	i.v.	N.D.	1	10
	F	i.v.	N.D.	1	10
Rats*	M	p.o.	393**		
	F	p.o.	686**		

\* Sprague Dawley Rats from Shizouka Lab Animal Centre, Hamamatsu, Japan

\*\* Besylate Salt

+ Dogs from Interfauna, France

++ Dogs from Japan

N.D. Not Determined: The result did not permit calculations of LD50 values. Thus, range of lethal doses is given.

The main clinical signs in the oral studies were somnolence, decreased spontaneous movement and for rats salivation, dyspnea, ptosis, lacrimation, blanching, cyanosis, rough coat, abdominal distension, and eventually coma. After i.v. injection, the animals died rapidly showing only somnolence, tachypnea or ptosis.

**Single-Dose Studies (Maximum Tolerated Dose)**

SPECIES	ROUTE	DOSE base mg/kg/day	ANIMALS PER DOSE LEVEL	DURATION	FINDINGS
Dog	Oral (gavage)	4 8 16	2 M	Single Dose	<p><u>At all dose levels:</u> Vasodilation and increases in plasma aldosterone levels.</p> <p><u>At 4 mg/kg:</u> Compensatory tachycardia.</p> <p><u>At 8 mg/kg:</u> In 1 of 2 dogs vomiting, sedation, respiratory distress and diarrhea 48 hr post-dose; normal at day 5. Compensatory tachycardia.</p> <p><u>At 16 mg/kg:</u> Moribund with hyperthermia within 24 hours; low blood pressure returned to normal over 2-6 days; transient raise in heart rate.</p> <p><u>Histological examination</u> showed congestion, edema and hemorrhage of the right atrial wall in the 2 dogs at 16 mg/kg. The hemorrhage in the right atrial wall corresponds to the right atrial lesions seen in long-term studies with amlodipine and other vasodilators (see long-term toxicity). One of 2 dogs at each dose showed fibrosis of the left ventricle in the subendocardial region and the posterior papillary muscle.</p> <p>The maximum tolerated dose was not determined.</p>
Dog (Japanese Study)	Oral	3.5 7	1 M 1 F	Single Dose	<p><u>Mortality:</u> 1 male dog at 7 mg/kg. Decreased spontaneous movement and flushing of palpebral conjunctiva and buccal cavity.</p> <p><u>At 7 mg/kg:</u> 1 female vomiting; 1 male hypothermia, lying prone.</p> <p>Hematology/Clinical Chemistry: Increase in WBC and BUN at 10 and 5 mg/kg (males).</p> <p>The maximum tolerated dose was not determined.</p>

### Subacute and Chronic Toxicity

SPECIES	ROUTE	DOSE base mg/kg/day	ANIMALS PER DOSE LEVEL	DURATION	FINDINGS
Mouse	Oral (diet)	0 2.5 5 10	10 M 10 F	2 Months	<p><u>At 10 mg/kg/day:</u> Mice died during week 2 of the study.</p> <p><u>At 5 mg/kg/day (males and females) and 2.5 mg/kg/day (males):</u> Increase in water consumption.</p> <p><u>At 5 mg/kg/day - Pathology:</u> Drug-related increases in heart and liver weights.</p>
Rat (Japanese Study)	Oral (gavage)	0 4 16 32 64	12 M 12 F	1 Month	<p><u>At 64 mg/kg/day:</u> All rats died within 9 days.</p> <p><u>At 32 mg/kg/day:</u> 12/24 rats died; decreased food consumption, growth inhibition, ptosis, decreased spontaneous movement.</p> <p><u>At 16 and 32 mg/kg/day:</u> The pattern of results on heart weights, increased urinary volume, effect on electrolyte balance and the adrenals was similar to that of the 6 month study below; increase in BUN at 16 mg/kg (males) and at 32 mg/kg (males and females).</p>
Rat (Japanese Study)	Oral (gavage)	0 2 7 21	16 M 16 F	3 Months followed by 1 Month drug withdrawal	<p><u>21 mg/kg/day:</u> Salivation, growth inhibition, increased BUN, increased urinary volume, effect on electrolyte balance and adrenals was similar to that of the 6 month study below. Also <u>post-mortem</u> dilation of small intestine without morphological lesions.</p> <p><u>At 7 mg/kg/day:</u> Alterations in urinary electrolytes excretion.</p> <p>No drug related effects at the end of 1 month drug withdrawal phase.</p>
Rat	Oral (gavage)	0 2.5 5 10	20 M 20 F	6 Months	<p><u>At all dose levels:</u> Renal effects: increased urinary volume and/or Na/K/Cl excretion, decreased plasma Na/K and/or Ca/Cl and increased urea; <u>Post-mortem:</u> Increase in heart weights.</p> <p><u>At 10 mg/kg/day:</u> Renal effects: increased kidney weight.</p> <p><u>Histopathology:</u> Thickening of zona glomerulosa at 5 and 10 mg/kg/day.</p>



SPECIES	ROUTE	DOSE base mg/kg/day	ANIMALS PER DOSE LEVEL	DURATION	FINDINGS
Rat (Japanese Study)	Oral (gavage)	1.4 7 18	30 M 30 F	12 Months (interim sacrifice 5/sex/group after 6 months)	<p><u>Mortality</u>: 3 rats (2 males and 1 female) at 18 mg/kg/day.</p> <p><u>At 18 mg/kg/day</u>: Salivation, growth inhibition; Renal effects: increase in urinary volume with increased electrolytes excretion and decreased serum electrolytes; increase in BUN.</p> <p><u>At 7 mg/kg/day</u>: Growth inhibition (males); Renal effects: increases of urinary volume and electrolyte excretion.</p> <p><u>Post-mortem</u>: Increases of adrenal weights (at 18/mg/kg), increases of relative heart weight (18 and 7 mg/kg), dilated small intestines without morphological change (18 mg/kg).</p> <p><u>Histopathology - Main Finding</u>: Enlargement of the zona glomerulosa of the adrenals (18 and 7 mg/kg).</p>
Dog	Oral (gavage)	0.5 to 4	2 M 2 F	10 Days Supple- mentary Dose Escalation Study (0.5 mg/kg/day)	<p><u>At 4 mg/kg</u>: Death of all (4/4) dogs preceded in 3 dogs by low systolic blood pressure, bradycardia, disturbances of heart rhythm and conduction. Clinical signs included pale skin, hypothermia and prostration.</p> <p><u>Histopathology</u>: Showed foci of myocyte necrosis and sarcoplasmic vacuolation in the left ventricle, papillary muscle and left and right atria. Congestion and/or edema in several organs (i.e. gastrointestinal tract/gall bladder wall and surrounding tissues as well as the connective tissue surrounding both kidneys).</p>
Dog	Oral	0 0.25 0.5 1	3 M 3 F	6 Months	<p><u>At all dose levels</u>: Increase in urinary volume and urinary excretion of electrolytes (not dose-related). Reduction in blood pressure and increases in heart rate.</p> <p><u>At 1 mg/kg/day - Pathology</u>: Increase in relative heart weights in 4/6 dogs, inflammatory lesion of the right atrial wall was seen which was considered to be consequence of excessive hemodynamic changes.</p>

SPECIES	ROUTE	DOSE base mg/kg/day	ANIMAL PER DOSE LEVEL	DURATION	FINDINGS
Dog	Oral	0 0.125 0.25 0.5	4 M 4 F	12 Months	<p><u>At 0.5 mg/kg/day:</u> Reduction in blood pressure and increases in heart rate; increase in urinary volume and urinary excretion of electrolytes (females).</p> <p><u>At 0.5 mg/kg/day - Pathology:</u> Showed inflammatory lesions of the right atrial wall in 1/8 dogs, similar to that of the 6 month study above, and diffuse gingival hyperplasia.</p>

### Genotoxicity

Study	Test Organism	Dose	Route	Major Findings
<b>Ames Test</b> (modified) Quantitative Plate Assay (QAP) and Metabolic Activation (MA) with Hepatic Microsomes	<i>Salmonella typhimurium</i> : Strains TA 1535, TA 1537, TA 98 and TA 100	10-0.02 mg/plate (QAP) 0.2-0.0005 mg/plate (MA)	<i>In vitro</i>	No evidence of mutation frequency.
<b>In-vivo Cytogenetic Tests</b>	mouse bone marrow	20 mg/kg single dose 10 mg/kg/day for 5 days	<i>In vivo</i> p.o. s.c.	No indication of chromosome breakage or mutagenicity observed.
<b>In vitro Cytogenetic Tests</b> with or without metabolic activation [rat liver microsomal enzymes (S-9)]	human lymphocytes	Without metabolic activation: 0.01 to 1000 µg/ml of culture medium With metabolic activation: 1.0 to 25 µg/ml of culture medium.	<i>In vitro</i>	<u>Non-activation:</u> No evidence of induced chromosome breakage observed at levels of 1.0 µg/mL and below. At levels higher than 1.0 µg/mL, compound produced mitotic inhibition. <u>Activation:</u> No drug induced clastogenic activity observed at levels up to 10 µg/mL. Higher levels produced mitotic inhibition.
Quantitative Plate Assay (QAP) of Mouse Urine	<i>Salmonella typhimurium</i> Strains: TA 1535, TA 1537, TA 98 and TA 100.	0, 1, 10 and 20 mg/kg	<i>In vivo</i> p.o.	No incidence of an excreted mutagen.
L 5178Y/TK +/- Gene Mutation Assay with and without liver S-9 fraction	mouse lymphoma cells	1.2 - 38 µg/mL	<i>In vitro</i>	No evidence of gene mutational activity.

## **Carcinogenicity**

There was no evidence of a carcinogenic effect when amlodipine was administered in the diet for up to 24 months to rats up to 2.5 mg/kg/day. Amlodipine was also administered for up to 24 months of dietary administration to mice at doses up to 2.5 mg/kg/day and no evidence of carcinogenicity was observed.

## **Reproductive and Developmental Toxicology**

<b>Species</b>	<b>Route</b>	<b>Dose base/mg/kg/day</b>	<b>Animal per Dose Level</b>	<b>Duration</b>	<b>Findings</b>
<b><i>Fertility</i></b>					
Rat (SD) (Japanese Study)	Oral (gavage)	0 1.4 7 18	24 M + 24 F	Males 71 days prior to and during mating. Females 14 days prior to and during mating and up to 7 days of gestation.	<u>At 18 mg/kg</u> : Impairment of body weight gain (females). There were no effects of the drug on copulation or pregnancy rates, nor any evidence of embryotoxicity or teratogenicity.
<b><i>Teratology</i></b>					
Rat (Charles River CD/SD)	Oral (gavage)	0 2 5 10	20 F	Days 6-15 post insemination. Hysterectomies on day 20 of gestation.	No effects were observed.
Rat (SD) Japanese Study	Oral (gavage)	0 3 7 18	34 F	Days 7-17 post-insemination. 2/3 of dams sacrificed on day 21 of gestation. F1 generation followed.	No effects were observed except in the dams. <u>At 18 mg/kg</u> : Reduction in food intake and body weight gain.
Rabbit (Japanese White) Japanese Study	Oral	0 3 7 18	18 or 19 F	Day 6 to day 18 of gestation.	<u>At 18 and 7 mg/kg</u> : Decrease in maternal body weight (18 mg/kg) decrease in food consumption (18 and 7 mg/kg). No evidence of drug induced fetotoxicity or teratogenicity.

Species	Route	Dose base/mg/kg/day	Animal per Dose Level	Duration	Findings
<b>Peri- and Post-Natal Study</b>					
Rat (SD) Japanese Study	Oral (gavage)	0 1.4 2.8 7.0	25 F	Day 17 of gestation to day 21 post-partum.	As in the combined Fertility/Perinatal Study above; at the high dose level (7.0 mg/kg/day) adverse effects were observed on parturition and number of viable pups at birth and day 4 post-partum.

#### 14 SUPPORTING PRODUCT MONOGRAPHS

NORVASC® (amlodipine besylate Tablets 2.5, 5 and 10 mg), Submission Control No: 206420, Product Monograph, PFIZER CANADA INC, September 12, 2017.

## READ THIS FOR SAFE AND EFFECTIVE USE OF YOUR MEDICINE

### PATIENT MEDICATION INFORMATION

#### <sup>Pr</sup>pdp-AMLODIPINE

#### Amlodipine Besylate Oral Solution

Read this carefully before you start taking **pdp-AMLODIPINE** and each time you get a refill. This leaflet is a summary and will not tell you everything about this drug. Talk to your healthcare professional about your medical condition and treatment and ask if there is any new information about **pdp-AMLODIPINE**.

#### **What is pdp-AMLODIPINE used for?**

- Mild to moderate high blood pressure (hypertension).
- A type of chest pain called angina. It is used for patients who still have angina symptoms after receiving certain other medications.

pdp-AMLODIPINE can be used by itself or with other medicines to treat these conditions.

pdp-AMLODIPINE is approved for use in patients aged 6 and above.

#### **How does pdp-AMLODIPINE work?**

pdp-AMLODIPINE is a type of medicine known as a calcium channel blocker (CCB).

- It helps lower blood pressure by relaxing your blood vessels. This lets your blood flow more easily.
- pdp-AMLODIPINE also controls chest pain. It works to improve the supply of blood and oxygen to the heart and to reduce your heart's workload.

#### **What are the ingredients in pdp-AMLODIPINE?**

Medicinal ingredients: Amlodipine besylate

Non-medicinal ingredients: Glycerol, liquid maltitol, purified water

#### **pdp-AMLODIPINE comes in the following dosage form:**

Oral Solution 1 mg/mL

#### **Do not use pdp-AMLODIPINE if:**

- You are allergic to amlodipine (the active ingredient in pdp-AMLODIPINE), or to the non-medicinal ingredients listed above.
- You have ever had an allergic reaction to a similar type of drug (other calcium channel blockers).
- You have very low blood pressure (less than 90 mmHg systolic).
- You are breast-feeding. Do not breast-feed while taking pdp-AMLODIPINE because it transfers to breast milk.
- You have a genetic disorder where you have a build-up of glycerol in your body (hyper-glycerolemia).

**To help avoid side effects and ensure proper use, talk to your healthcare professional before you take pdp-AMLODIPINE. Talk about any health conditions or problems you may have, including if you:**

- Have or had any heart or blood vessel diseases, including heart failure.

- Have narrowing of a valve of your heart (aortic stenosis).
- Have liver or kidney problems.
- Are pregnant, or plan to become pregnant. pdp-AMLODIPINE should not be used during pregnancy unless your doctor tells you otherwise.
- Can't digest fructose, a simple sugar found in some foods. pdp-AMLODIPINE contains fructose.
- Are older than 65 years.

**Other warnings you should know about:**

- pdp-AMLODIPINE may sometimes cause low blood pressure. Your healthcare professional will monitor your blood pressure. Monitoring is important if you had a stroke or take other drugs to lower your blood pressure.
- pdp-AMLODIPINE is not recommended for use in children less than 6 years of age.
- Rarely, you may experience worse symptoms of angina, or have a heart attack while taking pdp-AMLODIPINE. This may happen more in patients who have a severe blockage in the arteries of their heart.
- If you have liver problems, you may receive a lower starting dose of pdp-AMLODIPINE. Your healthcare professional should also closely monitor your condition.
- pdp-AMLODIPINE contains glycerol. This may cause headache, upset stomach and diarrhea.

**Tell your healthcare professional about all the medicines you take, including any drugs, vitamins, minerals, natural supplements or alternative medicines.**

**The following may interact with pdp-AMLODIPINE:**

- Cyclosporine, sirolimus (used to suppress the immune system)
- Clarithromycin, erythromycin, rifampin (antibiotics)
- Diltiazem (calcium channel blocker)
- Phenobarbital, phenytoin (used to treat seizures)
- Ketoconazole, itraconazole (antifungal medications)
- Ritonavir (used to treat HIV)
- Beta-blockers
- Sildenafil (VIAGRA)
- Simvastatin, atorvastatin (used to treat high cholesterol)
- Tacrolimus (used to prevent the body from rejecting a transplanted organ)
- Temsirolimus, everolimus (used to treat cancer)
- St-John Wort (a natural health product)
- Grapefruit or grapefruit juice

**How to take pdp-AMLODIPINE:**

Take pdp-AMLODIPINE exactly as prescribed by your healthcare professional. It may be easier to take your dose at the same time every day. For example, you can take it with breakfast, lunch or at bedtime.

- This medicine contains 1 milligram (1 mg) of amlodipine in each 1 millilitre (1 mL) of solution.
- Take this medicine by mouth.
- Do NOT shake the bottle before use.
- Do NOT mix this medicine with food or beverages before use.
- Do not eat grapefruit or drink grapefruit juice while on pdp-AMLODIPINE.
- Do not stop taking pdp-AMLODIPINE before speaking with your doctor.

## Measuring your dose using the oral syringe provided

### Instructions for use

- **To open the bottle:** press the plastic screw cap and turn it counter-clockwise (Figure 1).
- Remove the plastic packaging from the syringe and syringe adaptor. Separate the syringe adaptor from the syringe. Insert the adaptor securely into the bottle neck (Figure 2). Leave the adaptor in the bottle neck for future use.
- Take the syringe and put it in the adaptor opening (Figure 3).



- Turn the bottle upside down (Figure 4).
- Fill the syringe with a small amount of solution by pulling the plunger down (Figure 4-A). Then push the plunger upward in order to remove any possible bubbles (Figure 4-B).

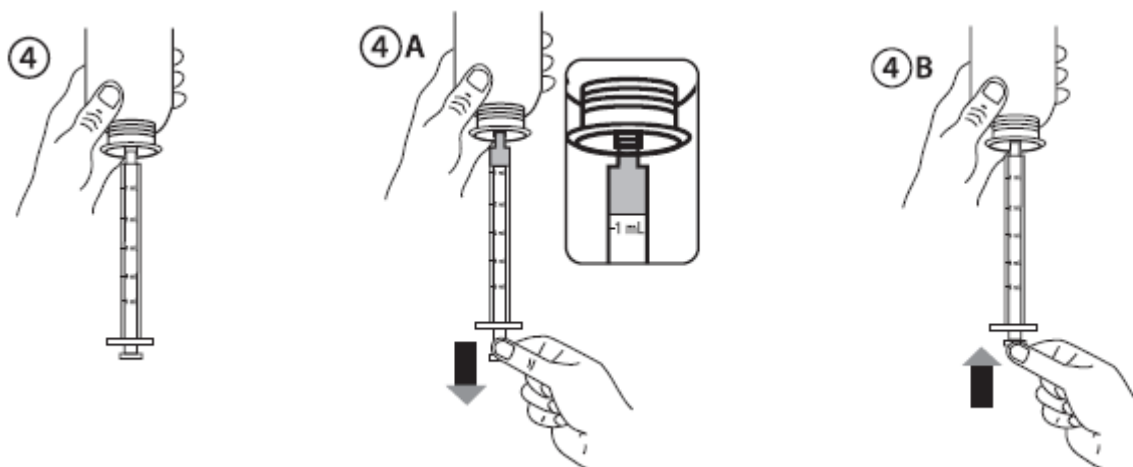

- Pull the plunger down to the line on the syringe that matches the quantity of millilitres (mL) prescribed by your doctor. Line up the top flat edge of the plunger with the quantity you need to take for your dose (Figure 4-C).

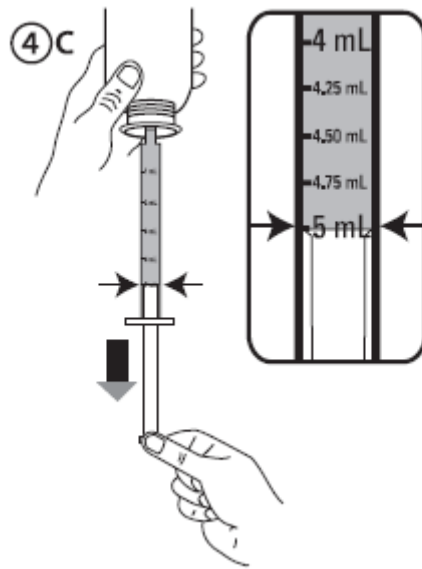

- Turn the bottle the right way up (Figure 5-A).
- Remove the syringe from the adaptor (Figure 5-B).
- Put the end of the syringe into the mouth and push the plunger slowly back in. This will release the medicine into your mouth.
- The syringe can hold 5 mL of pdp-AMLODIPINE. If your dose is greater than 5 mL, then you will need to repeat the last few steps to add more medication to the syringe.
- Wash the syringe with water and let it dry before you use it again (Figure 6).
- Close the bottle with the plastic screw cap. Leave the syringe adaptor in the bottle.

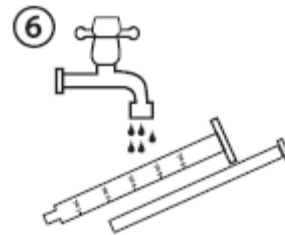
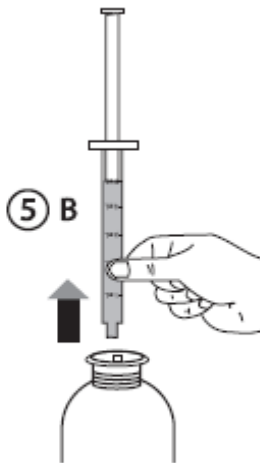
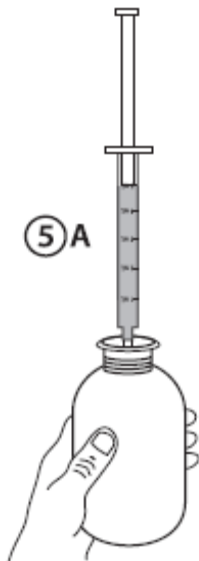



**Usual dose:**

For both high blood pressure and chest pain in adults, the recommended initial dose of pdp-AMLODIPINE is 5 mg (5 mL) once daily. If necessary, your doctor may increase your dose to a maximum dose of 10 mg (10 mL) once daily.

**Use in Patients with liver disease:**

The starting dose is 2.5 mg (2.5 mL) once daily and can be gradually increased by your doctor.

**Use in Children (6-17 years old):**

The recommended dose is 2.5 mg (2.5 mL) to 5 mg (5 mL) once daily.

**Overdose:**

If you think you have taken too much pdp-AMLODIPINE, contact your healthcare professional, hospital emergency department or regional poison control centre immediately, even if there are no symptoms.

One or more of the following signs may occur in an overdose:  
Low blood pressure and rapid heartbeat.

**Missed Dose:**

If you miss a dose, take it as soon as you remember. If it has been more than 12 hours since you missed your last dose, skip the missed dose and continue with the next dose at your regular time. Do not take double doses.

**What are possible side effects from using pdp-AMLODIPINE?**

These are not all the possible side-effects you may feel when taking pdp-AMLODIPINE. If you experience any side effects not listed here, contact your healthcare professional.

Side effects include:

- Headaches
- Tiredness, extreme sleepiness
- Stomach pain, nausea
- Dizziness

<b>Serious side effects and what to do about them</b>			
Symptom / effect	Talk to your healthcare professional		Stop taking drug and get immediate medical help
	Only if severe	In all cases	
<b>COMMON</b> <b>Flushing:</b> Hot or warm feeling in your face	✓		
<b>Edema:</b> Swelling of your legs or ankles	✓		
<b>UNCOMMON</b> <b>Arrhythmia:</b> Rapid, slow or irregular heartbeat		✓	
<b>Increased frequency, severity, duration of angina:</b> Pressing or squeezing pain in your chest		✓	
<b>Heart Attack:</b> Pain, fullness and/or squeezing of the chest, jaw pain and/or arm pain, shortness of breath			✓
<b>Liver Disorder:</b> Yellowing of the skin or eye, dark urine, abdominal pain, nausea, vomiting, loss of appetite		✓	
<b>Low Blood Pressure:</b> Dizziness, fainting, lightheadedness may occur when you go from lying or sitting to standing up	✓		
<b>RARE</b> <b>Allergic Reactions:</b> Rash, hives, swelling of the face, lips, tongue or throat, difficulty breathing or swallowing			✓
<b>Extrapyramidal symptoms:</b> Muscle stiffness, body spasms, upward eye rolling, exaggeration of reflexes, drooling, difficulty moving how and when you want			✓

If you have a troublesome symptom or side effect that is not listed here or becomes bad enough to interfere with your daily activities, talk to your healthcare professional.

## Reporting Side Effects

You can report any suspected side effects associated with the use of health products to Health Canada by:

- Visiting the Web page on Adverse Reaction Reporting (<https://www.canada.ca/en/health-canada/services/drugs-health-products/medeffect-canada.html>) for information on how to report online, by mail or by fax; or
- Calling toll-free at 1-866-234-2345.

*NOTE: Contact your health professional if you need information about how to manage your side effects. The Canada Vigilance Program does not provide medical advice.*

### Storage:

- Store in a refrigerator (2°C to 8°C).
- Keep the bottle stored upright.
- Discard 30 days after opening. Bring the bottle to your local pharmacist for proper disposal.
- Keep out of the reach and sight of children.

### If you want more information about pdp-AMLODIPINE:

- Talk to your healthcare professional
- Find the full product monograph that is prepared for healthcare professionals and includes this Patient Medication Information by visiting the Health Canada website (<https://health-products.canada.ca/dpd-bdpp/index-eng.jsp>); the manufacturer's website ([www.pendopharm.com](http://www.pendopharm.com)); or by calling 1-888-550-6060.

This leaflet was prepared by PENDOPHARM, Division of Pharmascience Inc.

Last Revised: January 11, 2019