

PRODUCT MONOGRAPH  
INCLUDING PATIENT MEDICATION INFORMATION

**ROTARIX**

Human rotavirus, live, attenuated, oral vaccine

Oral suspension

Active immunizing agent against infection caused by rotavirus

ATC Code: J07BC01

GlaxoSmithKline Inc.  
7333 Mississauga Road  
Mississauga, Ontario  
L5N 6L4

Date of Initial Authorization:  
Oct 09, 2007

Date of Revision:  
April 28, 2021

Submission Control Number: 239437

© 2021 GSK group of companies or its licensor  
Trademarks are owned by or licensed to the GSK group of companies

**RECENT MAJOR LABEL CHANGES**

6 DOSAGE FORMS, STRENGTHS, COMPOSITION AND PACKAGING, 8 ADVERSE REACTION, 10 CLINICAL PHARMACOLOGY	XXX 2021
---	----------

**TABLE OF CONTENTS**

Sections or subsections that are not applicable at the time of authorization are not listed.

**RECENT MAJOR LABEL CHANGES .....2**

**TABLE OF CONTENTS .....2**

**PART I: HEALTH PROFESSIONAL INFORMATION .....4**

**1 INDICATIONS .....4**

    1.1 Pediatrics .....4

**2 CONTRAINDICATIONS .....4**

**4 DOSAGE AND ADMINISTRATION .....4**

    4.1 Dosing Considerations .....4

    4.2 Recommended Dose and Dosage Adjustment.....4

    4.4 Administration.....5

**5 OVERDOSAGE .....8**

**6 DOSAGE FORMS, STRENGTHS, COMPOSITION AND PACKAGING .....8**

**7 WARNINGS AND PRECAUTIONS .....9**

    7.1 Special Populations..... 11

        7.1.1 Pregnant Women .....11

        7.1.2 Breast-feeding.....11

**8 ADVERSE REACTIONS .....11**

    8.1 Adverse Reaction Overview..... 11

    8.2 Clinical Trial Adverse Reactions ..... 11

        8.2.1 Clinical Trial Adverse Reactions – Pediatrics .....11

    8.5 Post-Market Adverse Reactions..... 15

**9 DRUG INTERACTIONS .....15**

    9.2 Drug Interactions Overview..... 15

    9.4 Drug-Drug Interactions ..... 16

9.5	Drug-Food Interactions .....	16
9.6	Drug-Herb Interactions .....	16
9.7	Drug-Laboratory Test Interactions .....	16
<b>10</b>	<b>CLINICAL PHARMACOLOGY .....</b>	<b>16</b>
10.1	Mechanism of Action.....	16
<b>11</b>	<b>STORAGE, STABILITY AND DISPOSAL .....</b>	<b>17</b>
<b>PART II: SCIENTIFIC INFORMATION .....</b>		<b>18</b>
<b>13</b>	<b>PHARMACEUTICAL INFORMATION.....</b>	<b>18</b>
<b>14</b>	<b>CLINICAL TRIALS.....</b>	<b>18</b>
14.1	Trial Design and Study Demographics .....	18
14.2	Study Results .....	20
<b>15</b>	<b>NON-CLINICAL TOXICOLOGY .....</b>	<b>27</b>
<b>PATIENT MEDICATION INFORMATION .....</b>		<b>28</b>

## **PART I: HEALTH PROFESSIONAL INFORMATION**

### **1 INDICATIONS**

#### **1.1 Pediatrics**

ROTARIX (human rotavirus, live, attenuated, oral vaccine) is indicated for:

- active immunization of infants from the age of 6 weeks for the prevention of gastroenteritis caused by circulating rotavirus strains (see [7 WARNINGS AND PRECAUTIONS](#) and [14 CLINICAL TRIALS](#)).

The results from clinical trials suggest that the vaccine's efficacy may vary with the type of rotavirus causing the infection (see [14 CLINICAL TRIALS](#)).

### **2 CONTRAINDICATIONS**

ROTARIX is contraindicated in:

- infants who are hypersensitive to this drug or to any ingredient in the formulation, including any non-medicinal ingredient, or component of the container. For a complete listing, see [6 DOSAGE FORMS, STRENGTHS, COMPOSITION AND PACKAGING](#).
- Infants who experienced hypersensitivity after previous administration of rotavirus vaccines.
- Infants with uncorrected congenital malformation (such as Meckel's diverticulum) of the gastrointestinal tract that would predispose for intussusception.
- Subjects with Severe Combined Immunodeficiency (SCID) disorder (see [8 ADVERSE REACTIONS](#)).
- Infants who have a history of intussusception.

### **4 DOSAGE AND ADMINISTRATION**

#### **4.1 Dosing Considerations**

- ROTARIX is for oral use only.
- UNDER NO CIRCUMSTANCES SHOULD ROTARIX BE INJECTED.

#### **4.2 Recommended Dose and Dosage Adjustment**

The vaccination course consists of two doses. The first dose can be administered from the age of 6 weeks. There should be an interval of at least 4 weeks between doses. ROTARIX may be given to preterm infants following the same vaccination course. This could be incorporated into the Canadian Immunization Schedule (2 and 4 months). Other immunization schedules have also been evaluated (see [14 CLINICAL TRIALS](#)). The administration of the 2 doses should be completed by the age of 24 weeks.

In particular circumstances, if the vaccine is given at an earlier age, and that the second dose is given within the shortest interval of 4 weeks, a lower immune response might be induced (see [14 CLINICAL TRIALS, Protective efficacy of ROTARIX liquid formulation](#)).

It is strongly recommended that infants who receive a first dose of ROTARIX complete the 2 dose regimen with ROTARIX. There are no data on safety, immunogenicity or efficacy when ROTARIX is administered for the first dose and another rotavirus vaccine is administered for the second dose or vice versa.

In clinical trials, spitting or regurgitation of the vaccine has rarely been observed and, under such circumstances, a replacement dose was not given. However, in the unlikely event that an infant spits out or regurgitates most of the vaccine dose, a single replacement dose may be given at the same vaccination visit.

There are no restrictions on the infant's consumption of food or liquid, including breastmilk, either before or after vaccination.

There is no evidence available to suggest that breastfeeding would reduce the protection against rotavirus gastroenteritis afforded by ROTARIX. Therefore, breastfeeding may be continued during the vaccination schedule.

The number of doses that would provide sufficient protection in immune compromised subjects has not been determined.

#### **4.4 Administration**

The vaccine is presented as a clear, colorless liquid, free of visible particles, for oral administration.

The vaccine is ready to use (no reconstitution or dilution is required).

The vaccine is to be administered orally without mixing with any other vaccines or solutions.

The vaccine should also be inspected visually for any foreign particulate matter and/or abnormal physical appearance prior to administration. In the event of either being observed, discard the vaccine. Any unused vaccine or waste material should be disposed of in accordance with local requirements.

This medicinal product must not be mixed with other medicinal products.

## Administration of the vaccine in tube

Please read the instructions for use all the way through before starting to give the vaccine.

### A What you need to do before giving Rotarix

- Check the expiry date.
- Check the tube has not been damaged nor is already open.
- Check the liquid is clear and colourless, without any particles in it.

If you notice anything abnormal, do not use the vaccine.

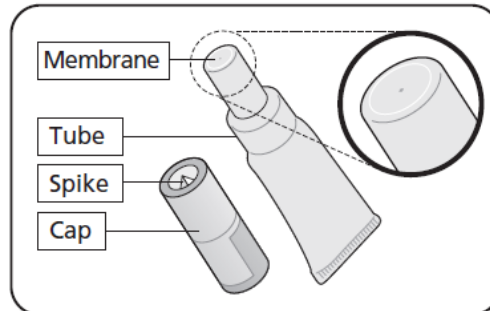

- This vaccine is given orally - straight from the tube.
- It is ready to use - you do not need to mix it with anything.

### B Get the tube ready

1. Pull off the cap
  - Keep the cap – you need this to pierce the membrane.
  - Hold the tube upright.
2. Repeatedly flick the top of the tube until it is clear of any liquid
  - Clear any liquid from the thinnest section of the tube by flicking just below the membrane.

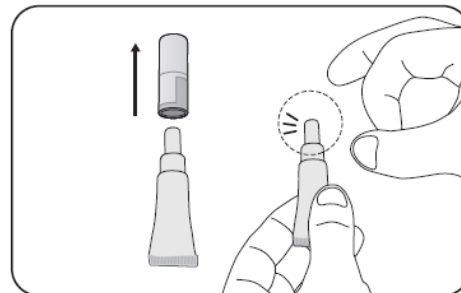

3. Position the cap to open the tube
  - Keep the tube held upright.
  - Hold the side of tube
  - There is a small spike inside the top of the cap - in the centre.
  - Turn the cap upside down (180°).

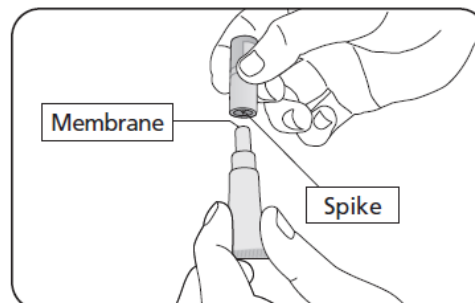

4. To open the tube

- You do not need to twist. Press the cap down to pierce the membrane.
- Then lift off the cap.

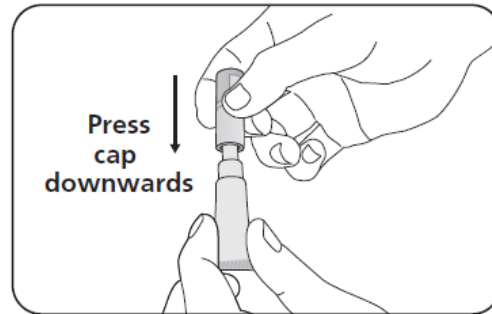

**C Check the tube has opened correctly**

1. Check the membrane has been pierced
  - There should be a hole at the top of the tube.

2. What to do if the membrane has not been pierced

- If the membrane has not been pierced return to section B and repeat steps 2, 3 and 4.

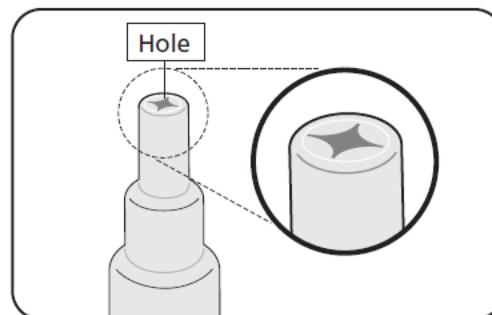

**D Give the vaccine**

- Once the tube is open check the liquid is clear, without any particles in it.
- If you notice anything abnormal, do not use the vaccine.
- Give the vaccine straight away.

1. Position the child to give the vaccine

- Seat the child leaning slightly backwards.

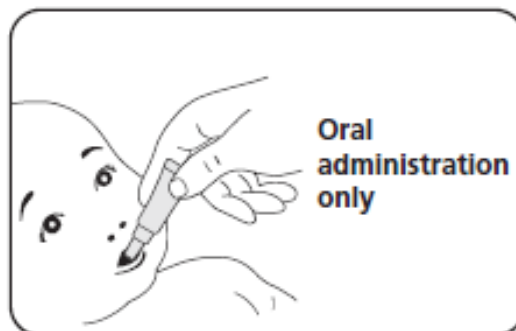

2. Administer the vaccine

- Squeeze the liquid gently into the side of the child's mouth - towards the inside of their cheek.
- You may need to squeeze the tube a few times to get all of the vaccine out - it is okay if a drop remains in the tip of the tube.

## 5 OVERDOSAGE

Some cases of overdose have been reported. In general, the adverse event profile reported in these cases was similar to that observed after administration of the recommended dose of ROTARIX.

For management of a suspected drug overdose, contact your regional poison control centre.

## 6 DOSAGE FORMS, STRENGTHS, COMPOSITION AND PACKAGING

To help ensure the traceability of vaccines for patient immunization record-keeping as well as safety monitoring, health professionals should record the time and date of administration, quantity of administered dose (if applicable), anatomical site and route of administration, brand name and generic name of the vaccine, the product lot number and expiry date.

**Table 1 Dosage Forms, Strengths, and Composition**

Route of Administration	Dosage Form / Strength / Composition	Non-medicinal Ingredients
Oral	Suspension/ Each 1.5 mL dose is formulated to contain not less than $10^{6.0}$ CCID <sub>50</sub> of human rotavirus RIX4414 strain (live, attenuated), produced on Vero cells.	Di-sodium adipate, Dulbecco's Modified Eagle Medium (DMEM), sucrose, and water for injection.

### Packaging

#### **Tube**

ROTARIX is available in a squeezable tube (LDPE) fitted with a membrane and a cap (polypropylene) in a pack size of 10.

#### **Description**

ROTARIX (human rotavirus, live, attenuated, oral vaccine) is a suspension presented in monodose oral applicators or monodose tubes for oral administration. The vaccine includes an antacid component to protect the vaccine during passage through the stomach and prevent its inactivation due to acidic environment.



## 7 WARNINGS AND PRECAUTIONS

### General

It is good clinical practice that vaccination should be preceded by a review of the medical history (especially with regard to previous vaccination and possible occurrence of undesirable events) and a clinical examination.

As with other vaccines, administration of ROTARIX should be postponed in infants suffering from acute severe febrile illness. However, the presence of a minor infection such as a cold should not result in the deferral of vaccination.

No safety or efficacy data are available for the administration of ROTARIX to:

- Individuals who have received a blood transfusion or blood products, including immunoglobulins, within 42 days.

No efficacy data are available for the administration of ROTARIX to:

- Immunocompromised patients such as individuals with malignancies receiving immunosuppressive therapy or who are otherwise immunocompromised.

The administration of ROTARIX should be postponed in infants suffering from diarrhea or vomiting.

Post-marketing safety studies indicate an increased incidence of intussusception after vaccination, mostly within 7 days of the first dose and, to a lesser extent, the second dose. The overall incidence of intussusception remains rare. It has not been established whether ROTARIX affects the overall risk of intussusception (see [8 ADVERSE REACTIONS, Clinical Trial Adverse Drug Reactions](#) and [Post-Market Adverse Drug Reactions](#)).

As a precaution, healthcare providers should follow-up on any symptoms indicative of intussusception (severe abdominal pain, persistent vomiting, bloody stools, abdominal bloating and/or high fever). Parents/guardians should be advised to promptly report such symptoms.

For subjects with a predisposition for intussusception (see [2 CONTRAINDICATIONS](#)). Excretion of the vaccine virus in the stools is known to occur after vaccination and lasts for 10 days on average with peak excretion around the 7<sup>th</sup> day. Viral antigen particles detected by ELISA were found in 50% (at day 7) of stools after the first dose and 17.4% (at day 3) and 4% (at day 7) of stools after the second dose. When these stools were tested for the presence of live vaccine strain, only 17% were positive. In clinical trials, cases of transmission of excreted vaccine virus to seronegative contacts of vaccinees have been observed without causing any clinical symptoms. ROTARIX should be administered with caution to individuals with immunodeficient close contacts, such as individuals with malignancies, or who are otherwise immunocompromised or receiving immunosuppressive therapy. Contacts of recent vaccinees should be advised to observe careful hygiene (including washing their hands) when changing children's diapers.

As with any vaccine, a protective immune response may not be elicited in all vaccinees.

The extent of protection that ROTARIX might provide against rotavirus strains that have not been circulating in clinical trials is currently unknown (see [14 CLINICAL TRIALS](#)).

ROTARIX does not protect against gastroenteritis due to other pathogens than rotavirus.

No data are available on the use of ROTARIX for post-exposure prophylaxis.

UNDER NO CIRCUMSTANCES SHOULD ROTARIX BE INJECTED.

### **Gastrointestinal**

There are no data on the safety and efficacy of ROTARIX in infants with gastrointestinal illnesses. Administration of ROTARIX may be considered with caution in such infants when, in the opinion of the physician, withholding the vaccine entails a greater risk.

### **Immune**

In some clinical trials, ROTARIX was not administered to infants known to have immunodeficient household members. There is a theoretical risk that the live virus vaccine can be transmitted to non-vaccinate contacts. Therefore, ROTARIX should be administered with caution to individuals known to have immunodeficient close contacts such as:

- Individuals with malignancies or who are otherwise immunocompromised; or
- Individuals receiving immunosuppressive therapy.

However, because nearly all children are infected with naturally occurring rotavirus by the age of 5 years, vaccination of infants may decrease the risk of exposure of immunodeficient household contacts to naturally occurring rotavirus. The health care provider should assess the potential risks and benefits of administering ROTARIX to infants known to have immunodeficient close contacts.

Asymptomatic and mildly symptomatic HIV infections are not expected to affect the safety or efficacy of ROTARIX. A clinical study in a limited number of asymptomatic or mildly symptomatic HIV positive infants showed no apparent safety problems (see [8 ADVERSE REACTIONS, Safety in Infants with Human Immunodeficiency \[HIV\] Infection](#)). Administration of ROTARIX in immunosuppressed infants, including infants on immunosuppressive therapy, should be based on careful consideration of potential benefits and risks.

### **Sensitivity/Resistance**

The vaccine contains 1073 mg of sucrose as an excipient. This amount is too low to cause adverse events in patients with rare hereditary problems such as fructose intolerance, glucose-galactose malabsorption or sucrase-isomaltase insufficiency.

## **7.1 Special Populations**

### **7.1.1 Pregnant Women**

ROTARIX is not intended for use in adults. Thus, human data on use during pregnancy are not available and animal reproduction studies have not been performed.

### **7.1.2 Breast-feeding**

Evidence from some clinical trials with ROTARIX suggests breastfeeding does not reduce the protection against rotavirus gastroenteritis afforded by ROTARIX. Therefore, breastfeeding may be continued during the vaccination schedule.

## **8 ADVERSE REACTIONS**

### **8.1 Adverse Reaction Overview**

The safety profile presented below is based on data from clinical trials conducted with either the lyophilized or the liquid formulation of ROTARIX.

In a total of four clinical trials, approximately 3,800 doses of ROTARIX liquid formulation were administered to approximately 1,930 infants. Those trials have shown that the safety and reactogenicity profile of the liquid formulation is comparable to the lyophilized formulation.

In a total of twenty-three clinical trials, approximately 106,000 doses of ROTARIX (lyophilized or liquid formulation) were administered to approximately 51,000 infants.

In three placebo controlled clinical trials (Finland, India and Bangladesh), in which, ROTARIX lyophilized formulation was administered alone (administration of routine pediatric vaccines was staggered), the incidence and severity of the solicited events (collected 8 days post vaccination), diarrhea, vomiting, loss of appetite, fever, irritability and cough/runny nose, were not significantly different in the group receiving ROTARIX when compared to the group receiving placebo. No increase in the incidence or severity of these events was seen with the second dose.

### **8.2 Clinical Trial Adverse Reactions**

Clinical trials are conducted under very specific conditions. The adverse reaction rates observed in the clinical trials; therefore, may not reflect the rates observed in practice and should not be compared to the rates in the clinical trials of another drug. Adverse reaction information from clinical trials may be useful in identifying and approximating rates of adverse drug reactions in real-world use.

#### **8.2.1 Clinical Trial Adverse Reactions – Pediatrics**

##### **Intussusception (also see Post-Market Adverse Drug Reactions)**

The risk of intussusception has been evaluated in a large safety trial conducted in Latin America and Finland where 63,225 infants were enrolled. No increased risk of intussusception in the ROTARIX group

was observed and observed rates were comparable to the placebo group. Data are shown below in Table 2 and Table 3.

**Table 2 Rate of intussusception within 31 days after administration**

<b>Intussusception</b>	<b>ROTARIX N=31,673</b>	<b>Placebo N=31,552</b>	<b>Relative risk (95% CI)</b>
First dose	1	2	0.50 (0.07; 3.80)
Second dose	5	5	0.99 (0.31; 3.21)

CI: Confidence Interval

**Table 3 Rate of intussusception up to one year of age**

<b>Intussusception</b>	<b>ROTARIX N=10,159</b>	<b>Placebo N=10,010</b>	<b>Relative Risk (95% CI)</b>
First dose up to one year	4	14	0.28 (0.10; 0.81)

CI: Confidence Interval

### **Solicited adverse reactions**

In study Rota-036, detailed safety information was collected by parents/guardians for 8 consecutive days following vaccination with ROTARIX (i.e. day of vaccination and the next 7 days). A diary card was completed to record irritability, cough/runny nose, the infant's temperature, loss of appetite, vomiting, or diarrhea on a daily basis during the first week following each dose of ROTARIX or placebo. Adverse reactions among recipients of ROTARIX and placebo occurred at similar rates (see Table 4 below).

**Table 4** Percentage of subjects with each solicited general symptom assessed as causally related to vaccination, reported from Day 0 to Day 7 after each RV1 vaccine/placebo dose – Rota-036 Pooled countries (Czech Republic, Finland, France, Germany, Italy and Spain)

Symptom	ROTARIX			Placebo		
	N	n	%	N	n	%
<b>Dose 1</b>						
Cough/Runny nose	914	58	6.3	490	29	5.9
Diarrhea	914	18	2.0	490	7	1.4
Fever	914	133	14.6	490	67	13.7
Irritability/Fussiness	914	299	32.7	490	171	34.9
Loss of appetite	914	126	13.8	490	71	14.5
Vomiting	914	44	4.8	490	24	4.9
<b>Dose 2</b>						
Cough/Runny nose	905	53	5.9	486	34	7.0
Diarrhea	905	6	0.7	486	8	1.6
Fever	905	164	18.1	486	95	19.5
Irritability/Fussiness	905	238	26.3	486	123	25.3
Loss of appetite	905	118	13.0	486	57	11.7
Vomiting	905	18	2.0	486	23	4.7

N = number of subjects having received the considered dose of RV1 vaccine/placebo

n/% = number/percentage of subjects with the specified symptom reported for the considered dose

ROTARIX and placebo groups had a similar incidence of each specified solicited symptom (any, grade 3 and related) reported from Day 0 to Day 7 after any ROTARIX/placebo doses.

### **Serious Adverse Events (SAEs):**

#### **Study Rota-023**

Among the total vaccinated cohort of 63,225 infants in study Rota-023 (31,673 in the RV1 group and 31,552 in the placebo group), a total of 1,975 subjects (948 [3.0%] infants in the RV1 vaccine group and 1,047 [3.3%] infants in the placebo group) reported at least one SAE (up to 30-90 days post Dose 2). No imbalance was observed between treatment groups for SAEs assessed as related to vaccination by the investigators. The overall SAE profile showed fewer SAEs/hospitalizations reported in the RV1 vaccine group compared to the placebo group, especially with respect to GE related SAEs.

In study Rota-023, a potential imbalance between groups was noted for reported cases of convulsions:

16 subjects in ROTARIX group (5.1/10,000) versus 6 subjects in the placebo group (1.9/10,000). Pooling of SAEs pertaining to "Convulsive disorders" ('Convulsions', 'Epilepsy', 'Grand mal convulsion', 'Status epilepticus' and 'Tonic convulsion'): resulted in 4 additional cases in the ROTARIX group and 6 additional cases in the placebo group.

### **Other clinical trials**

Infants were monitored for serious adverse events that occurred in the 31 day period following vaccination in 8 clinical studies. In these eight trials, 608 subjects reported at least one SAE (450 in vaccinees and 158 in placebo recipients). The incidence of subjects reporting at least one SAE in the group receiving ROTARIX (8.12%) was similar to the incidence in the placebo group (8.53%).

### **Deaths:**

In 8,262 infants enrolled and vaccinated in 10 completed trials, a total of 18 deaths were reported: 12 deaths in ROTARIX (0.19%, N=6,290) and 6 in placebo (0.30%, N=1,972). In the large safety study (Rota-023), 99 deaths occurred during the study<sup>1</sup>: 56 in ROTARIX group (0.18%, N=31,673) and 43 in the placebo group (0.14%, N=31,552). None of the cases were assessed as related to vaccination and no potential imbalance was detected for the 99 fatal cases in terms of overall mortality.

### **Safety in Preterm Infants:**

In a clinical study, 1,009 preterm infants were administered ROTARIX or placebo (198 were 27-30 weeks gestational age and 801 were 31-36 weeks gestational age). The first dose was administered from 6 weeks after birth. SAEs were observed in 5.1% of recipients of ROTARIX as compared to 6.8% of placebo recipients. Similar rates of solicited and unsolicited symptoms were observed in ROTARIX and placebo recipients. No cases of intussusception were reported. For premature infants born less than 36 weeks of gestation, and who remain hospitalized at the time of recommended administration, close monitoring for at least 48 hours after vaccination should be considered.

### **Safety in Infants with Human Immunodeficiency (HIV) Infection:**

In a clinical study, 100 infants with HIV infection were administered three doses of ROTARIX or placebo. The safety profile was similar between ROTARIX and placebo recipients.

### **Unsolicited Adverse Events (pooled analysis):**

Infants were monitored for unsolicited adverse events that occurred in the 31-day period following vaccination in 17 placebo controlled clinical studies (Europe, North America, Latin America, Asia, Africa) including trials in which ROTARIX was co-administered with routine pediatric vaccines (see [9 DRUG INTERACTIONS](#)). The following adverse reactions were considered as possibly related to vaccination:

---

<sup>1</sup> up to the data lock point.

**Table 5 Adverse reactions considered as possibly related to ROTARIX vaccination**

Frequency	Adverse Reaction	System/Organ Class
<b>Common:</b> ≥ 1% and < 10%	Diarrhea	Gastrointestinal disorders
	Irritability	General disorders and administration site conditions
<b>Uncommon:</b> ≥ 0.1% and < 1%	flatulence, abdominal pain	Gastrointestinal disorders
	Dermatitis	Skin and subcutaneous tissue disorders

### 8.5 Post-Market Adverse Reactions

The following events have been spontaneously reported during post-approval use of ROTARIX. Because these events were reported voluntarily from a population of uncertain size, it is not possible to reliably estimate their frequency or to establish a causal relationship to vaccine exposure.

**Gastrointestinal disorders:** Hematochezia, Intussusception\*<sup>^</sup>, Gastroenteritis with vaccine viral shedding in infants with Severe Combined Immunodeficiency (SCID) disorder.

\* See [7 WARNINGS AND PRECAUTIONS](#)

<sup>^</sup> Post-licensure studies and post-marketing spontaneous data suggest that intussusception following vaccination with ROTARIX is low and where it has been calculated, it occurs consistently at a rate less than 1 per 10,000 vaccinated infants (very rare) (see [14 CLINICAL TRIALS](#)).

**Infections and Infestations:** Kawasaki disease

## 9 DRUG INTERACTIONS

### 9.2 Drug Interactions Overview

Immunosuppressive therapies may reduce the immune response to vaccines. The potential interaction of these therapies with ROTARIX is not known.

#### Use with Other Vaccines

ROTARIX can be given concomitantly with any of the following monovalent or combination vaccines [including hexavalent vaccines (DTPa-HBV-IPV/Hib)]: diphtheria-tetanus-whole cell pertussis vaccine (DTPw), diphtheria-tetanus-acellular pertussis vaccine (DTPa), Haemophilus influenzae type b vaccine (Hib), inactivated polio vaccine (IPV), hepatitis B vaccine (HBV), pneumococcal conjugate vaccine and meningococcal serogroup C conjugate vaccine. Clinical studies demonstrated that the immune responses to and the safety profiles of the administered vaccines were unaffected.

In concomitant administration of ROTARIX and oral polio vaccine (OPV) clinical protection against severe rotavirus gastroenteritis was maintained. Concomitant administration of ROTARIX and OPV does not affect the immune response to the polio antigens but may reduce that to ROTARIX vaccine.

The immune response to ROTARIX is unaffected when OPV is administered 2 weeks apart from ROTARIX.

#### **9.4 Drug-Drug Interactions**

Interactions with other drugs have not been established.

#### **9.5 Drug-Food Interactions**

Interactions with food have not been established.

#### **9.6 Drug-Herb Interactions**

Interactions with herbal products have not been established.

#### **9.7 Drug-Laboratory Test Interactions**

Interactions with laboratory tests have not been established.

See

### **10 CLINICAL PHARMACOLOGY**

Rotavirus infection is the leading cause of severe acute gastroenteritis in infants and young children throughout the world. Rotavirus is transmitted mainly by the fecal-oral route, through close person-to-person contact, and through fomites. Ingested virus particles infect the cells in the villi of the small intestine, typically leading to villous atrophy. Characteristic clinical features include diarrhea, vomiting, fever and abdominal discomfort, occasionally leading to fatal dehydrating illness. Improvements or increased efforts in hygiene and sanitation are known to be of limited efficacy.

Rotavirus infection affects 95% of children by the age of 3 to 5 years worldwide. The incidence of rotavirus infections is highest in children between 6 and 24 months of age. Primary infection after 3 months of age usually causes the most severe disease. Subsequent infections are possible but typically cause much milder symptoms.

#### **10.1 Mechanism of Action**

ROTARIX contains a live, attenuated human rotavirus that replicates in the small intestine and induces immunity. ROTARIX vaccine is derived from the human 89-12 strain which belongs to G1 serotype and P[8] genotype. G1 is the most prevalent strain worldwide. It is known that the genotype P[8] is shared by most other circulating strains, including serotypes G3, G4 and G9.

The immunologic mechanism by which ROTARIX protects against rotavirus gastro-enteritis is not completely understood. A relationship between antibody responses to rotavirus vaccination and protection against rotavirus gastroenteritis has not been established.

**Duration of Protection:** Following two doses, ROTARIX is shown to provide at least 79% efficacy against severe rotavirus gastroenteritis through the second year of age (see [14 CLINICAL TRIALS](#)).



## **11 STORAGE, STABILITY AND DISPOSAL**

Store in a refrigerator (2°C to 8°C). Do not freeze.

In order to protect the vaccine from light it is recommended that the vaccine is stored in the original package.

The expiry date of the vaccine is indicated on the label and packaging.

## PART II: SCIENTIFIC INFORMATION

### 13 PHARMACEUTICAL INFORMATION

#### Drug Substance

Proper name: Human rotavirus, live, attenuated, oral vaccine.

#### Product Characteristics:

ROTARIX (human rotavirus, live, attenuated, oral vaccine) is a monovalent, live, attenuated virus vaccine derived from the human 89-12 strain which belongs to G1 serotype and P[8] genotype. G1 is the most prevalent strain worldwide. It is known that the genotype P[8] is shared by most other circulating strains, including serotypes G3, G4 and G9. Natural infection with the virus is not limited to the G and P related antigens, but also is associated with the structural proteins VP2 and VP6, in addition to VP7 and VP4 as well as with the non-structural proteins such as NSP4. It has been shown that the induction of an immune response following vaccination with an attenuated G1P[8] human strain is sufficient to provide cross-protection against severe gastroenteritis linked to different G strains.

### 14 CLINICAL TRIALS

#### 14.1 Trial Design and Study Demographics

##### Protective efficacy of ROTARIX lyophilized formulation

Clinical studies have been conducted in Europe, Latin America, Africa and Asia to evaluate the protective efficacy of ROTARIX against any and severe rotavirus gastroenteritis.

**Table 6 Study demographics and trial design**

Study No.	Trial design	Dosage and route of administration	No. of subjects	Mean age at administration in weeks (range)	Gender
<b>Rota-004</b>	Multi-centre, double blinded, randomized, placebo controlled study	Oral 2 doses of $10^{4.7}$ foci forming units (ffu) at 2 and 4 months of age	<u>First efficacy follow-up:</u> 245 Vaccine 123 Placebo  <u>Second efficacy follow-up:</u> 241 Vaccine 120 Placebo	<u>First dose:</u> Vaccine: 8.3 (6-12) Placebo: 8.2 (6-12)  <u>Second dose:</u> Vaccine: 16.3 (10-12) Placebo: 16.1(13-22)	Vaccine: Male 53.5%  Placebo: Male: 50.4%

Study No.	Trial design	Dosage and route of administration	No. of subjects	Mean age at administration in weeks (range)	Gender
<b>Rota-006</b>	Multi-centre, multi-country, double blind, randomized, placebo controlled study	Oral 2 doses (of either 10 <sup>4.7</sup> , 10 <sup>5.2</sup> or 10 <sup>5.8</sup> foci forming units (ffu)) at 2 and 4 months of age	<u>First efficacy follow-up:</u> 1,392 Vaccine 454 Placebo  <u>Second efficacy follow-up:</u> 332 Vaccine 109 Placebo	<u>First dose:</u> Vaccine*: 8.3 (6-12) Placebo: 8.3 (6-12)  <u>Second dose:</u> Vaccine: 17.9 (13-28) Placebo: 17.9 (13-26)	Vaccine & Placebo Male: 52%
<b>Rota-023</b>	Multi-centre, multi-country, double blinded, randomized, placebo controlled study	Oral 2 doses of 10 <sup>6.5</sup> CCID <sub>50</sub> at 2 and 3 to 4 months of age <sup>1</sup>	<u>First efficacy follow-up:</u> 9,009 Vaccine 8,858 Placebo  <u>Second efficacy follow-up:</u> 7,175 Vaccine 7,062 Placebo	<u>First dose:</u> Vaccine: 8.4 (5-13) Placebo: 8.4 (2-13)  <u>Second dose:</u> Vaccine: 16.3 (10-36) Placebo: 16.3 (9-30)	Vaccine: Male: 50.1% Placebo: Male: 52.0%
<b>Rota-036</b>	Multi-centre, multi-country, double blinded, randomized, placebo controlled study	Oral 2 doses of 10 <sup>6.5</sup> CCID <sub>50</sub> at a 2, 3 months, 2, 4 months, 3, 4 months or 3, 5 months schedule <sup>1</sup>	<u>First efficacy follow-up:</u> 2,572 Vaccine 1,302 Placebo  <u>Second efficacy follow-up:</u> 2,554 Vaccine 1,294 Placebo	<u>First dose:</u> Vaccine: 11.5 (5-18) Placebo: 11.5 (6-16)  <u>Second dose:</u> Vaccine: 19.7 (10-30) Placebo: 19.7 (10-27)	Vaccine: Male 53.6 % Placebo: Male: 50.9%
<b>Rota-037</b>	Multi-centre, multi-country, double blinded, randomized, placebo controlled study <sup>†</sup>	Oral 2 doses of 10 <sup>6.0</sup> CCID <sub>50</sub> at 10, 14 weeks; or 3 doses at 6, 10, 14 weeks <sup>1</sup>	<u>First efficacy follow-up:</u> 2,974 Vaccine 1,443 Placebo	<u>First dose</u> <sup>†</sup> : Vaccine: 6.3 (3-11) Placebo: 6.3 (2-11)  <u>Second dose</u> Vaccine: 11.3 (8-21) Placebo: 11.3 (9-19) <u>Third dose:</u> Vaccine: 16.2 (12-26) Placebo: 16.3 (12-25)	Vaccine: Male: 50.3%  Placebo: Male: 51.4%

<sup>1</sup> The administration schedule depends on the countries in which the studies were conducted.

\* This is applicable to the 10<sup>5.8</sup> ffu titre vaccine

<sup>†</sup> The placebo group received 3 doses of placebo at 6, 10, 14 weeks. The two-dose vaccine group received vaccine at weeks 10 and 14, but also placebo at the first dose (6 weeks), such that all participants received three blinded doses.

Clinical studies on protective efficacy were undertaken with ROTARIX lyophilized formulation, on which ROTARIX approval was based. Subsequently, clinical studies were undertaken with the liquid

formulation to assess the elicited immune response compared to the lyophilized formulation, including a non-inferiority study (see Protective efficacy of ROTARIX liquid formulation).

## 14.2 Study Results

### Rota-036

A clinical study performed in Europe (Rota-036) evaluated ROTARIX given according to different European schedules (2, 3 months; 2, 4 months; 3, 4 months; 3, 5 months) in more than 3,800 subjects. Severity of gastroenteritis was defined according to the Vesikari 20-point scale which evaluates the full clinical picture of rotavirus gastroenteritis by taking into account the severity and duration of diarrhea and vomiting, the severity of fever and dehydration as well as the need for treatment.

**Table 7 Efficacy following two doses of ROTARIX persisting through the first and second rotavirus seasons (Rota-036)**

	1 <sup>st</sup> Rotavirus Season		2 <sup>nd</sup> Rotavirus Season	
	Efficacy (%)	95% CI	Efficacy (%)	95% CI
Any rotavirus gastroenteritis	87.1*	79.6; 92.1	71.9*	61.2; 79.8
Severe rotavirus gastroenteritis (Vesikari score ≥11)	95.8*	89.6; 98.7	85.6*	75.8; 91.9
Rotavirus gastroenteritis requiring medical attention	91.8*	84; 96.3	76.2*	63.0; 85.0
Hospitalization due to rotavirus gastroenteritis	100*	81.8; 100	92.2*	65.6; 99.1

\* Statistically significant ( $p < 0.05$ )

Vaccine efficacy during the first year of life progressively increased with increasing disease severity, reaching 100% (95% CI: 84.7;100) for Vesikari scores  $\geq 17$ .

**Table 8 Strain-specific efficacy in 2,572<sup>†</sup> ROTARIX vaccine recipients and 1,302<sup>†</sup> placebo recipients through 2 rotavirus seasons (Rota-036)**

Type	Through One Rotavirus Season				Through Two Rotavirus Seasons			
	Rotavirus gastroenteritis of any severity		Severe rotavirus <sup>^</sup> gastroenteritis		Rotavirus gastroenteritis of any severity		Severe rotavirus <sup>^</sup> gastroenteritis	
	Efficacy (%)	95% CI	Efficacy (%)	95% CI	Efficacy (%)	95% CI	Efficacy (%)	95% CI
<b>G1[P8]</b>	95.6*	87.9;98.8	96.4*	85.7;99.6	89.8*	82.9;94.2	96.4*	90.4;99.1
<b>G2P[4]</b>	62.0	-124.4;94.4	74.7	-386.2;99.6	58.3*	10.1;81.0	85.5*	24.0;98.5
<b>G3[P8]</b>	89.9*	9.5;99.8	100.0*	44.8;100.0	84.8*	41.0;97.3	93.7*	52.8;99.9
<b>G4[P8]</b>	88.3*	57.5;97.9	100.0*	64.9;100.0	83.1*	55.6;94.5	95.4*	68.3;99.9
<b>G9[P8]</b>	75.6*	51.1;88.5	94.7*	77.9;99.4	72.9*	59.3;82.2	85.0*	71.7;92.6
<b>Strains with [P8] genotype</b>	88.2*	80.8;93.0	96.5*	90.6;99.1	n.a	n.a	n.a	n.a
<b>Pooled non G1 (G2, G3, G4, G9, G12)</b>	n.a	n.a	n.a	n.a	72.9*	62.9;80.5	87.7*	78.9;93.2

<sup>†</sup>ATP cohort for efficacy

\* Statistically significant (p<0.05)

<sup>^</sup> Severe gastroenteritis defined as a score  $\geq 11$  on the Vesikari scale.

A clinical study performed in Latin America (Rota-023) evaluated ROTARIX in more than 17,500 subjects. Severity of gastroenteritis was defined according to WHO criteria. The protective vaccine efficacy against severe rotavirus gastroenteritis requiring hospitalization and/or rehydration therapy in a medical facility and the strain specific vaccine efficacy after 2 doses of ROTARIX are presented in Table 9.

**Rota-023**

A clinical study performed in Latin America (Rota-023) evaluated ROTARIX in more than 17,500 subjects. Severity of gastroenteritis was defined according to WHO criteria. The protective vaccine efficacy against severe rotavirus gastroenteritis requiring hospitalization and/or rehydration therapy in a medical facility and the strain specific vaccine efficacy after 2 doses of ROTARIX are presented in Table 9.

**Table 9 Strain specific vaccine efficacy following 2 doses of ROTARIX (Rota-023)**

Type	Severe rotavirus gastroenteritis (1 <sup>st</sup> year of life) ROTARIX N=9,009; Placebo N=8,858		Severe rotavirus gastroenteritis (2 <sup>nd</sup> year of life) ROTARIX N=7,175; Placebo N=7,062	
	Efficacy (%)	95% CI	Efficacy (%)	95% CI
<b>All rotavirus gastroenteritis</b>	84.7*	71.7; 92.4	79.0*	66.4; 87.4
<b>G1P[8]</b>	91.8*	74.1; 98.4	72.4*	34.5; 89.9
<b>G2P[4]</b>	41.0	-79.2; 82.4	1.6	-7,626.1; 98.6
<b>G3P[8]</b>	87.7*	8.3; 99.7	71.9	-47.7; 97.1
<b>G4P[8]</b>	50.8#	-844; 99.2	63.1*	0.7; 88.2
<b>G9P[8]</b>	90.6*	61.7; 98.9	87.7*	72.9; 95.3
<b>Strains with P[8] genotype</b>	90.9*	79.2; 96.8	79.5*	67.0; 87.9

N=ATP cohort for efficacy

\*statistically significant (p<0.05)

# The numbers of cases on which the estimates of efficacy against G4P[8] were based were very small (1 case in the ROTARIX group and 2 cases in the placebo).

## G2P[4] serotype

Due to the rareness of the G2P[4] serotype, a meta analysis was performed. A pooled analysis of four efficacy studies, listed in Table 6, showed a 71.4% (95% CI:20.1;91.1) efficacy against severe rotavirus gastroenteritis (Vesikari score  $\geq 11$ ) caused by rotavirus G2P[4] type during the first year of life (see Table 10).

**Table 10** Pooled analysis of severe rotavirus G2P[4] gastroenteritis and ROTARIX efficacy in studies Rota-004, Rota-006, Rota-023, and Rota-036: 2 weeks after Dose 2 up to the end of the first year follow up

Study	ROTARIX N= ATP cohort for Efficacy n=severe rotavirus gastroenteritis			Placebo N= ATP cohort for Efficacy n=severe rotavirus gastroenteritis			Vaccine Efficacy (VE) *	
	N	n	%	N	n	%	%	95% CI
<b>Rota-004</b>	245	0	0.0	123	1	0.8	100.0	-1,858.0;100.0
<b>Rota-006</b>	1,392	0	0.0	454	3	0.7	100.0	21.1;100.0
<b>Rota-023</b>	9,009	5	0.1	8,858	9	0.1	45.4	-81.5;85.6
<b>Rota-036</b>	2,572	1	0.0	1,302	2	0.2	64.7	-386.2;99.57
<b>All*</b>	13,218	6	0.0	10,737	15	0.1	71.4	20.1;91.1

Results from the first efficacy follow-up period on the ATP cohort for efficacy

\*VE defined as 1-stratified Poisson rate ratio

## Rota-037

A clinical study performed in Africa (Rota-037) in more than 4,900 subjects evaluated ROTARIX given at approximately 10 and 14 weeks of age (2 doses, n=1,647) or 6, 10 and 14 weeks of age (3 doses, n=1,651). The 2- and 3-dose regimens were pooled and compared against placebo (n=1,641). The vaccine efficacy against severe rotavirus gastroenteritis (scored using the 20-point Vesikari scale) during the first year of life was 61.2 % (96.2 % CI: 42.9;73.7). The study was not powered to evaluate a difference in vaccine efficacy between the 2- and 3-dose regimens. The protective vaccine efficacy observed against any and severe rotavirus gastro-enteritis is presented in Table 11.

**Table 11 Study conducted in Africa: 1st year of life – pooled results (ROTARIX N=2,974; Placebo N = 1,443 (§))**

Vaccine efficacy (%) against any rotavirus gastro-enteritis [95% CI]*		
Strain	Any severity	Severe <sup>†</sup>
G1P[8]	68.3 [53.6; 78.5]	56.6 [11.8; 78.8]
G2P[4]	49.3 [4.6; 73.0]	83.8 [9.6; 98.4]
G3P[8]	43.4 [<0; 83.7]	51.5 [<0; 96.5]
G8P[4]	38.7 [<0; 67.8]	63.6 [5.9; 86.5]
G9P[8]	41.8 [<0; 72.3]	56.9 [<0; 85.5]
G12P[6]	48.0 [9.7; 70.0]	55.5 [<0; 82.2]
Strains with P[4] genotype	39.3 [7.7; 59.9]	70.9 [37.5; 87.0]
Strains with P[6] genotype	46.6 [9.4; 68.4]	55.2 [<0; 81.3]
Strains with P[8] genotype	61.0 [47.3; 71.2]	59.1 [32.8; 75.3]

§ ATP cohort for efficacy

† Severe gastro-enteritis defined as a score  $\geq 11$  on the Vesikari scale

\* CI are unadjusted for interim analysis and multiplicity and should not be used to conclude on superiority over placebo



## Immune response

The immunologic mechanism by which ROTARIX protects against rotavirus gastroenteritis is not completely understood. A relationship between antibody responses to rotavirus vaccination and protection against rotavirus gastroenteritis has not been established. The following table shows the percentage of infants initially seronegative for rotavirus (IgA antibody titres < 20 U/mL (by ELISA)) and with serum anti-rotavirus IgA antibody titres  $\geq$  20 U/mL one to two months after the second dose of vaccine or placebo as observed in different studies (see Table 12).

**Table 12** Percent of infants with serum anti-rotavirus IgA antibody titres  $\geq$  20 U/mL 1 to 2 months after the second dose

Schedule	Studies conducted in	Vaccine			Placebo		
		N	% $\geq$ 20 U/mL	95% CI	N	% $\geq$ 20 U/mL	95% CI
2, 3 months	France, Germany	239	82.8	77.5; 87.4	127	8.7	4.4; 15.0
2, 4 months	Spain	186	85.5	79.6; 90.2	89	12.4	6.3; 21.0
3, 5 months	Finland, Italy	180	94.4	90.0; 97.3	114	3.5	1.0; 8.7
3, 4 months	Czech Republic	182	84.6	78.5; 89.5	90	2.2	0.3; 7.8
2, 3 to 4 months	Latin America; 11 countries	393	77.9	73.8; 81.6	341	15.1	11.7; 19.0
10, 14 weeks and 6, 10, 14 weeks (pooled)	South Africa, Malawi	221	58.4	51.6; 64.9	111	22.5	15.1; 31.4

### Immune Response in Preterm Infants

In a clinical study conducted in preterm infants, ROTARIX was immunogenic; 85.7% of subjects achieved serum anti-rotavirus IgA antibody titres  $\geq$  20 U/mL (by ELISA) one month after the second dose of the vaccine.

### **Protective efficacy of ROTARIX liquid formulation**

Four controlled studies were undertaken with ROTARIX liquid formulation to assess elicited immune response. Three of these were comparative studies in which healthy infants were enrolled to receive two doses of ROTARIX liquid or lyophilized formulations, given at the age of 2 and 3 months (Rota-048), 2 and 4 months (Rota-057), or 3 and 4 months (Rota-061). The immune response elicited by ROTARIX liquid formulation was comparable to that elicited by the lyophilized formulation (see Table 13).

**Table 13** Percent of infants with serum anti-rotavirus IgA antibody titres  $\geq 20$ U/mL 1 month after the second dose

Schedule	Studies conducted in	Liquid Formulation			Lyophilized Formulation		
		N	% $\geq 20$ U/mL	95% CI	N	% $\geq 20$ U/mL	95% CI
2, 3 months	Finland	80	90.0	81.2; 95.6	86	83.7	74.2; 90.8
2, 4 months	Panama	449	80.8	76.9; 84.4	434	73.5	69.1; 77.6
3, 4 months	Finland	746	88.6	86.1; 90.8	252	90.5	86.2; 93.8

In a study conducted in Vietnam (Rota-051), the immune response in terms of seroconversion rates and GMCs in the group that received two doses of ROTARIX liquid vaccine with the first and second dose given at 8 and 12 weeks of age (4 weeks apart) was lower than the response in the group that received two doses of ROTARIX liquid vaccine with the first and second dose given at 8 and 16 weeks of age (8 weeks apart).

Serum anti-RV IgA antibodies are generally accepted as a valid surrogate marker of protection, and published data suggests that the ROTARIX-induced serum anti-RV IgA antibodies might be a good correlate of vaccine induced protection, despite the absence of an established immune correlate of protection. The immune response observed after two doses of ROTARIX liquid formulation was comparable to the immune response observed after 2 doses of ROTARIX lyophilized formulation, the vaccine efficacy for the liquid formulation is assumed to be similar to that observed with the lyophilized formulation.

#### **Post-Authorization Safety Study**

A post-authorization safety study was undertaken in Mexico to evaluate the temporal association between ROTARIX administration (co-administered with other EPI vaccines) and definite intussusception occurrence within 31 days (Day 0 to Day 30) following vaccination. The analysis was performed on a cohort of children (N=698) diagnosed with intussusception, who had received at least one dose of rotavirus vaccine and with available dates of rotavirus vaccine administration, date of birth and onset date of intussusception. The study results indicated a temporal association between administration of ROTARIX and intussusception in the 31 days post Dose 1, and the effect was observed to be concentrated in the first week post Dose 1. The study results did not indicate a temporal association between ROTARIX and intussusception in the 31 days post Dose 2.

#### **Post-Authorization Observational Studies**

A self controlled case series analysis and a matched case-control analysis were undertaken in infants immunized between July 2007 and June 2010 in Australia to evaluate cases of intussusception in the 21 day period following any vaccination with rotavirus vaccines. Data from this study indicate the likelihood of a small increased risk of intussusception following the first dose of ROTARIX. The study also found an increased risk of intussusception after Dose 2 of ROTARIX, but the risk was smaller than after Dose 1.

A meta-analysis of postmarketing surveillance studies conducted in Australia, Mexico, Brazil and the United States was performed to provide a single estimate of the risk of intussusception following the

first and second dose of ROTARIX. The studies varied in terms of design and statistical power, and used different methods to estimate the risk; all studies included a risk estimation for the 7-day period after dose 1 and dose 2 separately, and obtained data through active and/or passive surveillance on confirmed intussusception cases. The overall estimate of risk of intussusception during the 7 days after vaccination was 5.39 (95% CI: 3.92; 7.41) after dose 1 and 1.81 (95% CI: 1.31; 2.49) after dose 2. These results indicate a transient increased incidence of intussusception after vaccination, mostly within 7 days of the first dose and, to a lesser extent, the second dose.

## **15 NON-CLINICAL TOXICOLOGY**

Preclinical data reveal no special hazard for humans based on conventional studies of repeated dose toxicity.

## **PATIENT MEDICATION INFORMATION**

### **READ THIS FOR SAFE AND EFFECTIVE USE OF YOUR VACCINE**

#### **ROTARIX**

#### **Human rotavirus, live, attenuated, oral vaccine**

#### **Oral suspension**

Read this carefully before your child receives **ROTARIX**. This leaflet is a summary and will not tell you everything about this vaccine. Talk to your healthcare professional about your child's medical condition and treatment and ask if there is any new information about **ROTARIX**.

#### **What is ROTARIX used for?**

- ROTARIX is a viral vaccine, containing live, attenuated human rotavirus, that helps to protect your child against gastroenteritis (diarrhea and vomiting) caused by rotavirus infection.
- Rotavirus infection is the most common cause of severe diarrhea in infants and young children. Rotavirus is easily spread from hand-to-mouth due to contact with stools from an infected person. Most children with rotavirus diarrhea recover on their own. However, some children become very ill with severe vomiting, diarrhea and life-threatening loss of fluids that requires hospitalization. Rotavirus infections are responsible for hundreds of thousands of deaths worldwide every year especially in developing countries, where nutrition and health care are not optimal.

#### **How does ROTARIX work?**

When your child receives this vaccine, his/her immune system (the body's natural defence) will make antibodies that will recognize the most commonly occurring types of rotavirus. These antibodies protect against disease caused by these types of rotavirus and will protect your child from infection.

As with all vaccines, ROTARIX may not completely protect all children who are vaccinated.

#### **What are the ingredients in ROTARIX?**

Medicinal ingredients: ROTARIX consists of live, attenuated human rotavirus.

Non-medicinal ingredients: di-sodium adipate, Dulbecco's Modified Eagle Medium (DMEM), sucrose, and water for injection.

#### **ROTARIX comes in the following dosage forms:**

Suspension for oral administration.

#### **Do not use ROTARIX if:**

- your child has previously had any allergic reaction to rotavirus vaccines or any component contained in ROTARIX (the medicinal ingredient and other ingredients in ROTARIX; see "What are the ingredients in ROTARIX"). Signs of an allergic reaction may include itchy skin rash, shortness of breath and swelling of the face or tongue.

- your child has ever had intussusception or was born with a malformation of the gastrointestinal system that would predispose for intussusception (a bowel obstruction in which one segment of bowel becomes enfolded within another segment).
- your child has a rare inherited illness which affects their immune system called Severe Combined Immunodeficiency (SCID).

**To help avoid side effects and ensure proper use, talk to your healthcare professional before your child receives ROTARIX. Talk about any health conditions or problems you may have, including if your child:**

- suffers from disorders of the stomach or intestines.
- has an intolerance to some sugars (see “What are the ingredients in ROTARIX, Non-Medicinal Ingredients”).
- has any disease or is taking any medicine which reduces his/her resistance to infection
- has a severe infection with a high temperature. It might be necessary to postpone the vaccination until recovery. A minor infection such as a cold should not be a problem, but talk to your doctor first.
- has diarrhea or is vomiting. It might be necessary to postpone the vaccination until recovery.

**Tell your healthcare professional about all the medicines you take, including any drugs, vitamins, minerals, natural supplements or alternative medicines.**

**Take special care with ROTARIX:**

Excretion of the live vaccine virus in the stools of the vaccinated children is known to occur after vaccination, especially around the 7<sup>th</sup> day. Persons in contact with recently vaccinated children should wash their hands after changing the child’s diapers.

ROTARIX should be given with caution to children in close contact with individuals having any disease or receiving any medicine which may reduce his/her resistance to infection.

**The following may interact with ROTARIX:**

Please tell your doctor if your child is taking or has recently taken any other medicines, including medicines obtained without a prescription, or has recently received any other vaccine.

ROTARIX may be given at the same time your child receives other normally recommended vaccinations, such as diphtheria, tetanus, pertussis (whooping cough), *Haemophilus influenzae* type b, inactivated polio, hepatitis B, pneumococcal vaccines as well as meningococcal serogroup C conjugate vaccine.

**How to take ROTARIX:**

**Usual dose:**

The Health Care provider will administer the recommended dose of ROTARIX to your child. The vaccine (1.5 mL liquid) will be given orally. **Under no circumstance should this vaccine be administered by injection.**

Your child will receive two doses of the vaccine. Each dose will be given on a separate occasion with an interval of at least 4 weeks between the two doses. The first dose may be given from the age of 6 weeks. The two doses of the vaccine must have been given by the age of 24 weeks, although they should preferably have been given before 16 weeks of age.

ROTARIX may be given to infants who were born prematurely following the same vaccination course.

Your doctor may suggest giving the ROTARIX vaccine during the 2 and 4 month visits when getting some of the other vaccines.

In case your child spits out or regurgitates most of the vaccine dose, a single replacement dose may be given at the same vaccination visit.

There are no restrictions on the infant's consumption of food or liquid, including breastmilk, either before or after the vaccination.

When ROTARIX is given to your child for the first dose, it is recommended that your child also receives ROTARIX (and not another rotavirus vaccine) for the second dose.

#### **Overdose:**

Some cases of overdose have been reported. In general, the side effects reported are similar to those seen after administration of the recommended dose of ROTARIX.

If you think you, or a person you are caring for, have taken too much ROTARIX, contact a healthcare professional, hospital emergency department, or regional poison control centre immediately, even if there are no symptoms.

#### **Missed Dose:**

It is important that you follow the instructions of your Health Care Provider regarding return visits. If you forget to go back to your doctor at the scheduled time, ask your doctor for advice.

#### **What are possible side effects from using ROTARIX?**

Like all medicines, ROTARIX can cause side effects, although not everybody gets them. Side effects that occurred during clinical trials with ROTARIX were as follows:

Common (side effects which may occur between 1% and 10% of doses):

- diarrhea
- irritability

Uncommon (side effects which may occur between 0.1% and 1% of doses):

- abdominal pain (see also below for signs of very rare side effects of intussusception)
- dermatitis
- flatulence

Side effects that occurred during routine use of ROTARIX include:

Rare:

- blood in stools
- children with a rare inherited illness called Severe Combined Immunodeficiency (SCID) may have an inflamed stomach or gut (gastroenteritis) and pass the vaccine virus in their stools. The signs of gastroenteritis may include feeling sick, being sick, stomach cramps or diarrhea.

Very rare:

- intussusception (part of the intestine gets blocked or twisted). The signs may include severe stomach pain, persistent vomiting, blood in stools, a swollen belly and/or high fever. **Contact a doctor/health care professional right away if your child experiences one of these symptoms.**

Contact your doctor right away if your child experiences any of the above rare side effects.

These are not all the possible side effects your child may feel when taking ROTARIX. If your child experiences any side effects not listed here, contact your healthcare professional.

#### **Reporting Suspected Side Effects for Vaccines**

**For the general public:** Should you experience a side effect following immunization, please report it to your healthcare professional.

Should you require information related to the management of the side effect, please contact your healthcare professional. The Public Health Agency of Canada, Health Canada and GlaxoSmithKline Inc. cannot provide medical advice.

**For healthcare professionals:** If a patient experiences a side effect following immunization, please complete the Adverse Events Following Immunization (AEFI) Form appropriate for your province/territory (<http://www.phac-aspc.gc.ca/im/ae-fi-ess-i-form-eng.php>) and send it to your local Health Unit.

**Storage:**

- Keep out of reach and sight of children.
- Store in a refrigerator (2°C to 8°C).
- Do not freeze.
- Store in original package to protect from light.

**If you want more information about ROTARIX:**

- Talk to your healthcare professional
- Find the full product monograph that is prepared for healthcare professionals and includes this Patient Medication Information by visiting the Health Canada website: <https://www.canada.ca/en/health-canada/services/drugs-health-products/drug-products/drug-product-database.html>; the manufacturer's website [www.gsk.ca](http://www.gsk.ca), or by calling 1-800-387-7374.

This leaflet was prepared by GlaxoSmithKline Inc.

Last Revised: April 28, 2021

*© 2021 GSK group of companies or its licensor  
Trademarks are owned by or licensed to the GSK group of companies*