

PRODUCT MONOGRAPH  
INCLUDING PATIENT MEDICATION INFORMATION

<sup>Pr</sup>**LAPELGA**<sup>®</sup>

pegfilgrastim Injection

Solution, 10 mg/mL,  
Subcutaneous Injection Only

Professed Standard

Hematopoietic Agent,  
Granulocyte Colony-Stimulating Factor

Apotex Inc.  
150 Signet Drive  
Toronto, Ontario  
M9L 1T9

**Date of Initial Approval:**  
April 5, 2018

**Date of Revision:**  
October 4, 2024

**Submission Control No:** 286594

## RECENT MAJOR LABEL CHANGES

<u>7 WARNINGS AND PRECAUTIONS, Carcinogenesis and Mutagenesis</u>	5/2022
<u>7 WARNINGS AND PRECAUTIONS, Hematologic</u>	5/2022

## TABLE OF CONTENTS

Sections or subsections that are not applicable at the time of authorization are not listed.

<b>PART I: HEALTH PROFESSIONAL INFORMATION.....</b>	<b>4</b>
<b>1 INDICATIONS.....</b>	<b>4</b>
1.1 Pediatrics (< 18 years of age): .....	4
<b>2 CONTRAINDICATIONS .....</b>	<b>4</b>
<b>3 SERIOUS WARNINGS AND PRECAUTIONS BOX .....</b>	<b>4</b>
<b>4 DOSAGE AND ADMINISTRATION.....</b>	<b>4</b>
4.1 Dosing Considerations .....	4
4.2 Recommended Dose and Dosage Adjustment .....	5
4.3 Reconstitution .....	5
4.4 Administration .....	5
4.5 Missed Dose .....	5
<b>5 OVERDOSAGE .....</b>	<b>5</b>
<b>6 DOSAGE FORMS, STRENGTHS, COMPOSITION AND PACKAGING .....</b>	<b>6</b>
<b>7 WARNINGS AND PRECAUTIONS .....</b>	<b>7</b>
7.1 Special Populations.....	9
7.1.1 Pregnant Women .....	9
7.1.2 Breast-feeding.....	10
7.1.3 Pediatrics .....	10
7.1.4 Geriatrics.....	10
<b>8 ADVERSE REACTIONS.....</b>	<b>10</b>
8.1 Adverse Reaction Overview .....	10
8.2 Clinical Trial Adverse Reactions .....	10
8.3 Less Common Clinical Trial Adverse Reactions .....	12
8.4 Abnormal Laboratory Findings: Hematologic, Clinical Chemistry and Other Quantitative Data .....	13
8.5 Post-Market Adverse Reactions.....	13
<b>9 DRUG INTERACTIONS.....</b>	<b>14</b>
9.1 Serious Drug Interactions Box .....	14
9.2 Drug Interactions Overview .....	14
9.3 Drug-Behavioural Interactions.....	14
9.4 Drug-Drug Interactions .....	14
9.5 Drug-Food Interactions .....	14
9.6 Drug-Herb Interactions.....	14
9.7 Drug-Laboratory Test Interactions .....	14

<b>10</b>	<b>ACTION AND CLINICAL PHARMACOLOGY</b> .....	<b>14</b>
10.1	Mechanism of Action.....	14
10.2	Pharmacodynamics.....	15
10.3	Pharmacokinetics.....	15
<b>11</b>	<b>STORAGE, STABILITY AND DISPOSAL</b> .....	<b>16</b>
<b>12</b>	<b>SPECIAL HANDLING INSTRUCTIONS</b> .....	<b>17</b>
<b>PART II: SCIENTIFIC INFORMATION</b> .....		<b>18</b>
<b>13</b>	<b>PHARMACEUTICAL INFORMATION</b> .....	<b>18</b>
<b>14</b>	<b>CLINICAL TRIALS</b> .....	<b>18</b>
14.4	Clinical Trials – Reference Biologic Drug.....	18
<b>15</b>	<b>MICROBIOLOGY</b> .....	<b>20</b>
<b>16</b>	<b>NON-CLINICAL TOXICOLOGY</b> .....	<b>20</b>
<b>17</b>	<b>SUPPORTING PRODUCT MONOGRAPHS</b> .....	<b>22</b>
<b>PATIENT MEDICATION INFORMATION</b> .....		<b>23</b>
<b>PATIENT MEDICATION INFORMATION</b> .....		<b>38</b>

Lapelga® (pegfilgrastim Injection) is a biosimilar biologic drug (biosimilar) to Neulasta. A biosimilar is a biologic drug that was granted authorization based on a demonstration of similarity to a version previously authorized in Canada, known as the reference biologic drug.

## PART I: HEALTH PROFESSIONAL INFORMATION

### 1 INDICATIONS

The indication has been granted on the basis of similarity between Lapelga® and the reference biologic drug Neulasta (pegfilgrastim).

Lapelga® (pegfilgrastim) is indicated to decrease the incidence of infection, as manifested by febrile neutropenia, in patients with non-myeloid malignancies receiving myelosuppressive anti-neoplastic drugs.

#### 1.1 Pediatrics (< 18 years of age):

No data are available to Health Canada; therefore, Health Canada has not authorized an indication for pediatric use.

### 2 CONTRAINDICATIONS

Lapelga® (pegfilgrastim) is contraindicated in patients with known hypersensitivity to *E. coli*-derived proteins, pegfilgrastim, filgrastim, or to any ingredient in the formulation, including any non-medicinal ingredient, or to component of the container. For a complete listing of the components, see the [6 DOSAGE FORMS, STRENGTHS, COMPOSITION AND PACKAGING](#) section of the Product Monograph.

### 3 SERIOUS WARNINGS AND PRECAUTIONS BOX

#### Serious Warnings and Precautions

- Splenic rupture, including fatal cases, has been reported following the administration of pegfilgrastim and its parent compound, filgrastim (see [7 WARNINGS AND PRECAUTIONS: General](#)).
- Severe sickle cell crises have been associated with the use of pegfilgrastim in patients with sickle cell trait or sickle cell disease. Severe sickle cell crises, in some cases resulting in death, have also been associated with filgrastim, the parent compound of pegfilgrastim (see [7 WARNINGS AND PRECAUTIONS: Hematologic](#)).

### 4 DOSAGE AND ADMINISTRATION

#### 4.1 Dosing Considerations

Lapelga® (pegfilgrastim) should be administered no sooner than 24 hours after the administration of cytotoxic chemotherapy (see [7 WARNINGS AND PRECAUTIONS](#)).

Renal impairment, including end-stage renal disease, appears to have no effect on the

pharmacokinetics of Lapelga® and no dosage adjustment is required.

#### 4.2 Recommended Dose and Dosage Adjustment

The recommended dose of Lapelga® is a single subcutaneous injection of 6 mg, administered once per cycle of chemotherapy. Lapelga® should be administered no sooner than 24 hours after the administration of cytotoxic chemotherapy (see [7 WARNINGS AND PRECAUTIONS](#)).

Health Canada has not authorized an indication for pediatric use for Lapelga® (see [INDICATIONS](#)).

#### 4.3 Reconstitution

Not applicable. Product does not need to be reconstituted.

#### 4.4 Administration

Lapelga® is intended for subcutaneous injection only and should not be given by any other route of administration. Lapelga® should not be mixed with any diluents. Lapelga® should not be vigorously shaken.

Lapelga® Pre-filled Syringe Lapelga® is supplied in single-use pre-filled syringes with a \*BD UltraSafe Plus™ Passive Needle Guard to prevent accidental needle stick injury. When the pre-filled syringe is emptied of all the medication, the passive needle-guard mechanism pushes over the needle, withdrawing it from the skin and covering it completely. The pre-filled syringe should be disposed of by placing the entire pre-filled syringe with guard activated into an approved puncture-proof container.

\*BD UltraSafe Plus™ Passive is a trademark of Becton, Dickinson and Company.

#### Lapelga® Pre-filled Autoinjector

Lapelga® is supplied in a single-use pre-filled autoinjector. The autoinjector was designed to allow for simplified and accurate dose delivery making dose administration easier. The pre-filled autoinjector should be disposed of by placing the entire pre-filled autoinjector into an approved puncture-proof container.

#### 4.5 Missed Dose

If a scheduled dose is missed, Lapelga® should not be administered less than 14 days before subsequent administration of cytotoxic chemotherapy.

### 5 OVERDOSAGE

The maximum tolerated dose of Lapelga® (pegfilgrastim) has not been determined in humans. Pegfilgrastim administered at a dose of 300 mcg/kg (n = 12), approximately three times the recommended dose, exhibited an adverse event profile similar to that observed at the recommended dose.

For management of a suspected drug overdose, contact your regional poison control centre.
---

## 6 DOSAGE FORMS, STRENGTHS, COMPOSITION AND PACKAGING

To help ensure the traceability of biologic products, including biosimilars, health professionals should recognize the importance of recording both the brand name and the non-proprietary (active ingredient) name as well as other product-specific identifiers such as the Drug Identification Number (DIN) and the batch/lot number of the product supplied.

**Table 1. Dosage Forms, Strengths, Composition and Packaging**

<b>Route of Administration</b>	<b>Dosage Form / Strength/Composition</b>	<b>Non-medicinal Ingredients</b>
Subcutaneous (SC) Injection	Solution / 10 mg/mL	Acetate polysorbate 20 sorbitol water for injection

Lapelga<sup>®</sup> (pegfilgrastim) is a sterile, clear, colourless, preservative-free liquid for SC administration. Each single-use pre-filled syringe and single-use pre-filled autoinjector (0.6 mL) of Lapelga<sup>®</sup> (10 mg/mL) contains 6 mg of pegfilgrastim (based on protein mass only). The product is formulated at pH 4.0 in 10 mM acetate, 5% sorbitol, 0.004% polysorbate 20 and water for injection (q.s. to 0.6 mL).

### Availability of Dosage Forms

#### Lapelga<sup>®</sup> Pre-filled Syringe

Lapelga<sup>®</sup> is supplied as a preservative-free solution (0.6 mL) containing 6 mg of pegfilgrastim (10 mg/mL) in a 1 mL, glass (USP Type I), single-use pre-filled syringe with a 27 gauge, ½ inch needle, and a BD UltraSafe PLUS<sup>™</sup> Passive<sup>™</sup> Needle Guard.

Lapelga<sup>®</sup> is provided in a carton containing one blister packaged pre-filled syringe along with the package insert.

The Lapelga<sup>®</sup> syringe plunger stopper and needle cover are not made with natural rubber latex.

#### Lapelga<sup>®</sup> Pre-filled Autoinjector

Lapelga<sup>®</sup> is supplied as a preservative-free solution (0.6 mL) containing 6 mg of pegfilgrastim (10 mg/mL) in a 1 mL, glass (USP Type I), single-use autoinjector containing a pre-filled syringe with a 27 gauge and ½ inch needle.

Lapelga<sup>®</sup> is provided in a carton containing one pre-filled autoinjector along with the package insert.

The needle cover on the single-use pre-filled autoinjector is not made with natural rubber latex.

To reduce the risk of accidental needle sticks to users, each single-use pre-filled syringe is equipped with a BD UltraSafe PLUS<sup>™</sup> Passive Needle Guard that is passively activated to cover the needle during disposal.

### Description

Lapelga® (pegfilgrastim) is a biosimilar product that is a long-acting form of recombinant human granulocyte colony-stimulating factor (r-metHuG-CSF) or filgrastim. Lapelga® is composed of filgrastim with a 20,000 dalton polyethylene glycol (PEG) molecule covalently bound to the N-terminal methionine residue. Filgrastim is a 175 amino acid protein with a molecular weight of 18,800 daltons; Lapelga® has a total molecular weight of 39,000 daltons.

## 7 WARNINGS AND PRECAUTIONS

Please see the [7 SERIOUS WARNINGS AND PRECAUTIONS BOX](#) at the beginning of Part I: Health Professional Information.

### General

Lapelga® (pegfilgrastim) has not been evaluated for PBPC (peripheral blood progenitor cell) mobilization. Therefore, it should not be used in that setting.

**Splenic Rupture:** Splenic rupture, including fatal cases, has been reported following the administration of pegfilgrastim and its parent compound, filgrastim. Patients receiving Lapelga® who report left upper abdominal and/or shoulder tip pain should be evaluated for an enlarged spleen or splenic rupture.

**Simultaneous Use with Chemotherapy and Radiation Therapy:** The safety and efficacy of Lapelga® administered concurrently with cytotoxic chemotherapy have not been established. Because of the potential for an increase in sensitivity of rapidly dividing myeloid cells to cytotoxic chemotherapy, Lapelga® should not be administered in the period between 14 days before and 24 hours after administration of cytotoxic chemotherapy (see [4 DOSAGE AND ADMINISTRATION](#)).

The safety and efficacy of Lapelga® have not been evaluated in patients receiving chemotherapy associated with delayed myelosuppression (eg, nitrosoureas), mitomycin C, or myelosuppressive doses of anti-metabolites such as 5-fluorouracil (5-FU). Concomitant use of pegfilgrastim with 5-FU or other anti-metabolites has not been evaluated in humans; although it has been studied and shown to potentiate myelosuppression in animal models (see [16 NON-CLINICAL TOXICOLOGY](#)).

The safety and efficacy of pegfilgrastim have not been evaluated in patients receiving radiation therapy, except for patients with breast or lung cancer.

### Carcinogenesis and Mutagenesis

No carcinogenesis or mutagenesis studies were conducted with Lapelga®.

**Potential Effect on Malignant Cells:** Lapelga® (pegfilgrastim) and filgrastim are growth factors that primarily stimulate production of neutrophils and neutrophil precursors by binding to the G-CSF receptor. Overall, the possibility that Lapelga® can act as a growth factor for any tumour type cannot be excluded. The use of Lapelga® in chronic myeloid leukemia (CML) and myelodysplastic syndrome (MDS) has not been studied. .

**MDS and AML in Breast Cancer and Lung Cancer Patients:** In the post-marketing observational study setting, findings showed that pegfilgrastim is associated with an increased risk of MDS and AML in breast and lung cancer patients when used in conjunction with

chemotherapy and/or radiotherapy. Monitor patients for signs and symptoms of MDS/AML in these settings.

## **Cardiovascular**

**Aortitis:** Aortitis has been reported in patients receiving pegfilgrastim and may present with generalized signs and symptoms such as fever and increased inflammatory markers. Consider aortitis in patients who develop these signs and symptoms without known etiology.

**Capillary Leak Syndrome:** Capillary leak syndrome (CLS) has been reported after the administration of pegfilgrastim or filgrastim. CLS can cause circulatory shock and may be fatal, and is characterized by hypotension, hypoalbuminemia, edema, and hemoconcentration. Episodes vary in frequency, severity and may be life-threatening if treatment is delayed. Patients who develop symptoms of capillary leak syndrome should be closely monitored and receive treatment, which may include a need for intensive care.

## **Hematologic**

**Sickle Cell Crises:** Severe sickle cell crises have been associated with the use of Lapelga® in patients with sickle cell trait or sickle cell disease. Severe sickle cell crises, in some cases resulting in death, have also been associated with filgrastim, the parent compound of pegfilgrastim. Only physicians qualified by specialized training or experience in the treatment of patients with sickle cell trait and sickle cell disease should prescribe Lapelga® for such patients, and only after careful consideration of the potential risks and benefits.

**Leukocytosis:** In clinical studies with pegfilgrastim, white blood cell counts of  $100 \times 10^9/L$  or greater have been reported in less than 1% of patients with cancer receiving myelosuppressive chemotherapy (n = 930), and were not associated with any reported adverse clinical effects (see [7 WARNINGS AND PRECAUTIONS. Monitoring and Laboratory Tests](#)).

In studies of pegfilgrastim administration after chemotherapy, most reported side effects were consistent with those usually seen as a result of cytotoxic chemotherapy (see [8 ADVERSE REACTIONS](#)). Because of the potential for patients to receive full doses of chemotherapy on the prescribed schedule, patients may be at greater risk of thrombocytopenia, anemia, and non-hematologic consequences of increased chemotherapy doses (please refer to the prescribing information for specific chemotherapy agents). Regular monitoring of hematocrit value and platelet count is recommended. Furthermore, care should be exercised in the administration of Lapelga® in conjunction with drugs known to lower platelet count.

**Thrombocytopenia:** Thrombocytopenia, including serious events, has been reported in patients receiving pegfilgrastim. Platelet counts should be monitored regularly as clinically indicated.

## **Immune**

**Hypersensitivity/Allergic Reactions:** Hypersensitivity including serious allergic reactions and anaphylactic reactions, skin rash, urticaria and erythema/flushing occurring on initial or subsequent treatment have been reported both with pegfilgrastim and filgrastim. In some cases, symptoms have recurred with rechallenge, suggesting a causal relationship. In rare cases, allergic reactions including anaphylaxis recurred within days after initial anti-allergic



treatment was discontinued. If a serious allergic reaction or an anaphylactic reaction occurs, appropriate therapy should be administered and further use of Lapelga® should be discontinued. Antibodies to filgrastim or pegfilgrastim have been reported, although no neutralizing antibodies have been reported (see [8 ADVERSE REACTIONS; Immunogenicity](#)). Do not administer Lapelga® to patients with a history of hypersensitivity to filgrastim or pegfilgrastim.

**Cutaneous Vasculitis:** Uncommon ( $\geq 1 / 1,000$  to  $< 1 / 100$ ) events of cutaneous vasculitis have been reported in patients treated with pegfilgrastim. The mechanism of vasculitis in patients receiving Lapelga® is unknown.

## Monitoring and Laboratory Tests

To assess a patient's hematologic status and ability to tolerate myelosuppressive chemotherapy, a complete blood count (CBC) and platelet count should be obtained before chemotherapy is administered. Pegfilgrastim produced ANC (absolute neutrophil count) profiles similar to daily filgrastim, including earlier ANC nadir, shorter duration of severe neutropenia, and accelerated ANC recovery, compared with ANC profiles observed without growth factor support. Regular monitoring of hematocrit value, white blood cell count and platelet count, as clinically indicated, is recommended.

## Renal

**Glomerulonephritis:** Glomerulonephritis has been reported in patients receiving filgrastim and pegfilgrastim. Generally, events of glomerulonephritis resolved after dose reduction or withdrawal of filgrastim and pegfilgrastim. Urinalysis monitoring is recommended.

## Respiratory

**Acute respiratory distress syndrome (ARDS):** Acute respiratory distress syndrome (ARDS) has been reported following administration of pegfilgrastim and is postulated to be secondary to an influx of neutrophils to sites of inflammation in the lungs. Neutropenic patients receiving Lapelga® who develop fever, lung infiltrates, or respiratory distress should be evaluated for the possibility of ARDS. In the event that ARDS occurs, Lapelga® should be discontinued and/or withheld until resolution of ARDS and patients should receive appropriate medical management for this condition.

## Sexual Function/Reproduction

No studies evaluating sexual function or reproduction in humans were conducted with pegfilgrastim.

### 7.1 Special Populations

#### 7.1.1 Pregnant Women

There were no pregnant women exposed to pegfilgrastim in clinical trials. Lapelga® should be used during pregnancy only if the potential benefit outweighs the risk to the fetus (see [16 NON-CLINICAL TOXICOLOGY](#)).

### 7.1.2 Breast-feeding

It is not known whether pegfilgrastim is excreted in human milk. Because many drugs are excreted in human milk, Lapelga® is not recommended for women who are breast-feeding. Lapelga® should only be administered to a nursing woman if the potential benefit outweighs the risk.

### 7.1.3 Pediatrics

**Pediatrics (< 18 years of age):** The safety and effectiveness of Lapelga® in pediatric patients have not been established.

### 7.1.4 Geriatrics

**Geriatrics (> 65 years of age):** Of the total number of subjects with cancer who received pegfilgrastim in clinical studies (n = 930), 139 subjects (15%) were 65 years or older and 18 subjects (2%) were 75 years or older. No overall differences in safety or effectiveness were observed between these patients and younger patients, and other reported clinical experience has not identified differences in responses between the elderly and younger patients; however, due to the small number of elderly subjects, small but clinically relevant differences cannot be excluded.

## 8 ADVERSE REACTIONS

The adverse drug reaction profiles reported in clinical studies that compared Lapelga® to the reference biologic drug were comparable. The description of adverse reactions in this section is based on clinical experience with the reference biologic drug.

### 8.1 Adverse Reaction Overview

The most frequently reported study drug-related adverse event was bone pain, for which the incidence in patients treated with pegfilgrastim was similar to that in patients treated with filgrastim. Bone pain was generally reported as mild-to-moderate, could be controlled in most patients with non-narcotic analgesia.

See [7 WARNINGS AND PRECAUTIONS](#) regarding Splenic Rupture, ARDS, Hypersensitivity/Allergic Reactions, and Sickle Cell Crises.

### 8.2 Clinical Trial Adverse Reactions

Because clinical trials are conducted under very specific conditions, the adverse reaction rates observed in the clinical trials may not reflect the rates observed in practice and should not be compared to the rates in the clinical trials of another drug. Adverse drug reaction information from clinical trials is useful for identifying drug-related adverse events and for approximating rates.

Safety data are based on 7 randomized clinical trials involving 932 patients with lymphoma and solid tumours (breast and thoracic) who received pegfilgrastim after non-myeloablative cytotoxic chemotherapy. Common adverse events occurred at similar rates between the treatment arms in both the filgrastim-controlled trials (pegfilgrastim, n = 465; filgrastim, n = 331) and the placebo-controlled trial (pegfilgrastim, n = 467; placebo, n = 461). Most adverse experiences

were attributed by the investigator as the sequelae of the underlying malignancy or cytotoxic chemotherapy. In the filgrastim-controlled trials, these adverse experiences occurred at rates between 15% and 72% and included: nausea, fatigue, alopecia, diarrhea, vomiting, constipation, fever, anorexia, skeletal pain, headache, taste perversion, dyspepsia, myalgia, insomnia, abdominal pain, arthralgia, generalized weakness, peripheral edema, dizziness, granulocytopenia, stomatitis, mucositis and neutropenic fever. A summary of the most frequently reported adverse reactions in these randomized clinical trials can be found in [Table 2](#) and [Table 3](#).

In clinical trials comparing pegfilgrastim to filgrastim, medullary bone pain was reported in 26% of pegfilgrastim-treated patients, which was comparable to the incidence in filgrastim-treated patients. In the study comparing pegfilgrastim to placebo, the incidence of bone pain was 23% vs. 16%, respectively. This bone pain was generally reported to be of mild-to-moderate severity. Approximately 17% (for all bone pain type AEs; 10% for specifically “bone pain”) of all subjects utilized non-narcotic analgesics and less than 6% utilized narcotic analgesics in association with bone pain. No patient withdrew from study due to bone pain.

Across all studies, no life-threatening or fatal adverse events were attributed to pegfilgrastim. There was only one serious adverse event (dyspnea) reported as possibly related to pegfilgrastim in a single patient. No events of pleuritis, pericarditis, or other major systemic reactions to pegfilgrastim were reported.

No clinically significant changes in vital signs were observed. No evidence of interaction of pegfilgrastim with other drugs was observed in the course of clinical trials (see [7 WARNINGS AND PRECAUTIONS](#)).

**Table 2. Most Frequently\* Reported Adverse Reactions in Randomized Clinical Trials with Filgrastim as Comparator**

<b>Body System and Preferred Term</b>	<b>Pegfilgrastim n = 465 (%)</b>	<b>Filgrastim n = 331 (%)</b>
<b>Application Site</b>		
Injection Site Pain	16 (3%)	9 (3%)
<b>Body as a whole</b>		
Pain	8 (2%)	4 (1%)
Chest Pain (Non-Cardiac)	4 (1%)	3 (1%)
Edema Periorbital	3 (1%)	0 (0%)
Fever	3 (1%)	4 (1%)
<b>CNS/PNS</b>		
Headache	20 (4%)	12 (4%)
<b>Musculo-skeletal</b>		
Skeletal Pain	96 (21%)	89 (27%)
Myalgia	32 (7%)	25 (8%)
Arthralgia	27 (6%)	19 (6%)
Back Pain	19 (4%)	26 (8%)
Limb Pain	12 (3%)	7 (2%)
Musculo-Skeletal Pain	5 (1%)	4 (1%)
Neck Pain	4 (1%)	3 (1%)

\* Most frequently reported events were considered to be those events reported in  $\geq 1\%$  of the patients in the pegfilgrastim group.

**Table 3. Most Frequently\* Reported Adverse Reactions in Randomized Clinical Trials with Placebo Control**

<b>Body System and Preferred Term</b>	<b>Pegfilgrastim n = 467 (%)</b>	<b>Placebo n = 461 (%)</b>
<b>Blood and Lymphatic System Disorders</b>		
Leukocytosis	5 (1%)	1 (0%)
<b>Gastrointestinal Disorders</b>		
Diarrhea	9 (2%)	10 (2%)
<b>General Disorders and Administration Site Conditions</b>		
Pyrexia	8 (2%)	9 (2%)
Fatigue	3 (1%)	5 (1%)
<b>Infections and Infestations</b>		
Influenza	6 (1%)	5 (1%)
<b>Musculoskeletal and Connective Tissue Disorders</b>		
Bone Pain	62 (13%)	41 (9%)
Myalgia	26 (6%)	23 (5%)
Arthralgia	32 (7%)	19 (4%)
Polymyalgia	8 (2%)	7 (2%)
Musculoskeletal Pain	14 (3%)	5 (1%)
Pain in Limb	11 (2%)	5 (1%)
Back Pain	8 (2%)	4 (1%)
Polyarthralgia	5 (1%)	0 (0%)
<b>Nervous System Disorders</b>		
Headache	6 (1%)	2 (0%)
<b>Skin and Subcutaneous Tissue Disorders</b>		
Alopecia	8 (2%)	9 (2%)

\* Most frequently reported events were those events reported in  $\geq 1\%$  of the patients in the pegfilgrastim group.

### 8.3 Less Common Clinical Trial Adverse Reactions

The following adverse drug reactions were reported at an incidence of  $< 1\%$  in controlled clinical studies (occurring in more than 1 patient, with higher frequency than filgrastim):

**General Disorders and Administration Site Conditions:** injection site bruising;

**Infections and Infestations:** rhinitis;

**Nervous System Disorders:** hypertonia;

**Skin and Subcutaneous Tissue Disorders:** periorbital edema.

The following adverse drug reactions were reported at an incidence of  $< 1\%$  in controlled clinical studies (occurring in more than 1 patient, with higher frequency than placebo):

**General Disorders and Administration Site Conditions:** chest pain, pain.

## 8.4 Abnormal Laboratory Findings: Hematologic, Clinical Chemistry and Other Quantitative Data

Spontaneously reversible elevations in Lactate dehydrogenase (LDH), alkaline phosphatase, and uric acid of mild-to-moderate severity were observed. Most changes have been attributed to post-cytokine bone marrow expansion as well as to chemotherapy and metastatic disease. The incidences of these changes, presented for pegfilgrastim versus filgrastim and placebo, were: LDH (18% versus 29% and 18%), alkaline phosphatase (11% versus 16% and 12%), and uric acid [10% versus 9% and 13% (1% of uric acid reported cases for filgrastim and pegfilgrastim treatment groups were classified as severe)].

In clinical studies with pegfilgrastim, white blood cell counts of  $100 \times 10^9/L$  or greater have been reported in less than 1% of patients with cancer receiving myelosuppressive chemotherapy (n = 930), and were not associated with any reported adverse clinical effects.

### Immunogenicity

As with all therapeutic proteins, there is a potential for immunogenicity. The incidence of antibody development in patients receiving the reference product (Neulasta) has not been adequately determined. While available data suggest that a small proportion of patients developed binding antibodies to filgrastim or pegfilgrastim, the nature and specificity of these antibodies has not been adequately studied. No neutralizing antibodies have been detected using a cell-based bioassay in 46 (9%, n = 534) patients who apparently developed binding antibodies. The detection of antibody formation is highly dependent on the sensitivity and specificity of the assay, and the observed incidence of antibody positivity in an assay may be influenced by several factors including sample handling, concomitant medications, and underlying disease. Therefore, comparison of the incidence of antibodies to pegfilgrastim with the incidence of antibodies to other products may be misleading.

Cytopenias resulting from an antibody response to exogenous growth factors have been reported on rare occasions in patients treated with other recombinant growth factors. There is a theoretical possibility that an antibody directed against pegfilgrastim may cross-react with endogenous G-CSF, resulting in immune-mediated neutropenia, but this has not been observed in clinical studies.

For detailed immunogenicity information for Lapelga<sup>®</sup> see [CLINICAL TRIALS: Study Results Lapelga<sup>®</sup>, 14.3 Immunogenicity](#).

## 8.5 Post-Market Adverse Reactions

In addition to the events listed above, reports of adverse reactions have been identified post-market in patients receiving pegfilgrastim, including:

- Splenomegaly (enlarged spleen) and Splenic rupture (see [7 WARNINGS AND PRECAUTIONS, General, Splenic Rupture](#))
- Aortitis (see [7 WARNINGS AND PRECAUTIONS, Cardiovascular](#))
- Capillary Leak Syndrome (see [7 WARNINGS AND PRECAUTIONS, Cardiovascular](#))
- Sickle cell crisis (see [7 WARNINGS AND PRECAUTIONS, Hematologic](#))
- Myelodysplastic Syndrome (MDS) and Acute Myeloid Leukaemia (AML) in Breast and Lung Cancer Patients (see [7 WARNINGS AND PRECAUTIONS, Carcinogenesis and Mutagenesis](#))

- Allergic reactions (see [7 WARNINGS AND PRECAUTIONS, Immune, Hypersensitivity/Allergic Reactions](#))
- Cutaneous Vasculitis (see [7 WARNINGS AND PRECAUTIONS, Immune](#))
- Glomerulonephritis (see [7 WARNINGS AND PRECAUTIONS, Renal](#))
- Acute respiratory distress syndrome (ARDS) (see [7 WARNINGS AND PRECAUTIONS: Respiratory](#))
- Injection site reactions (pain, induration, and local erythema)
- Generalized erythema and flushing
- Sweet's syndrome (acute febrile neutrophilic dermatosis)

## **9 DRUG INTERACTIONS**

### **9.1 Serious Drug Interactions Box**

No serious drug interactions have been identified.

### **9.2 Drug Interactions Overview**

Drug interactions between pegfilgrastim and other drugs have not been studied. Drugs such as lithium that may potentiate the release of neutrophils should be used with caution; such patients should have more frequent monitoring of their neutrophil counts.

### **9.3 Drug-Behavioural Interactions**

Drug-behavioural interactions have not been established.

### **9.4 Drug-Drug Interactions**

Interactions with other drugs have not been established.

### **9.5 Drug-Food Interactions**

Interactions with food have not been established.

### **9.6 Drug-Herb Interactions**

Interactions with herbal products have not been established.

### **9.7 Drug-Laboratory Test Interactions**

Increased hematopoietic activity of the bone marrow in response to growth factor therapy has been associated with transient positive bone-imaging changes. This should be considered when interpreting bone-imaging results.

## **10 ACTION AND CLINICAL PHARMACOLOGY**

### **10.1 Mechanism of Action**

Pegfilgrastim and filgrastim are colony-stimulating factors that act on hematopoietic cells by binding to specific cell surface receptors thereby stimulating proliferation, differentiation, commitment, and end cell functional activation. Studies on cellular proliferation, receptor

binding, and neutrophil function demonstrate that filgrastim and pegfilgrastim have the same mechanism of action. Pegfilgrastim has reduced renal clearance and prolonged persistence *in vivo* as compared to filgrastim.

## 10.2 Pharmacodynamics

See information in 10.3 below.

## 10.3 Pharmacokinetics

The pharmacokinetics and pharmacodynamics of pegfilgrastim were studied in patients with cancer. The pharmacokinetics of pegfilgrastim were nonlinear in cancer patients and clearance decreased with increases in dose. Neutrophil-mediated clearance is an important component of the clearance of pegfilgrastim, and serum clearance is related to the number of neutrophils (neutrophil-mediated, self-regulating clearance). Consistent with a self-regulating clearance mechanism, the serum concentration of pegfilgrastim declined rapidly at the onset of neutrophil recovery, following myelosuppressive chemotherapy (see [Figure 1](#)). In addition to numbers of neutrophils, body weight appeared to be a factor. Patients with higher body weights experienced higher systemic exposure to pegfilgrastim after receiving a dose normalized for body weight. A large variability in the pharmacokinetics of pegfilgrastim was observed in cancer patients. The half-life of pegfilgrastim ranged from 25 to 49 hours after SC injection.

**Table 4. Summary of Pharmacokinetic Parameters of pegfilgrastim in Cancer Patients After SC Administration**

	<b>C<sub>max</sub></b>	<b>t<sub>½</sub> (h)</b>	<b>AUC<sub>0-∞</sub></b>	<b>Clearance</b>
<b>Single dose* Median</b>	78.3-175 ng/mL	25-49 hr	5640-15000 ng•hr/mL	6.68-17.7 mL/hr/kg

\* Doses of 100 mcg/kg and 6 mg

**Figure 1. Median Pegfilgrastim Serum Concentration and Absolute Neutrophil Count Profiles in Patients with Non-Small Cell Lung cancer (n=3) After a Single Injection of Pegfilgrastim 100 mcg/kg Administered Before and After Chemotherapy**

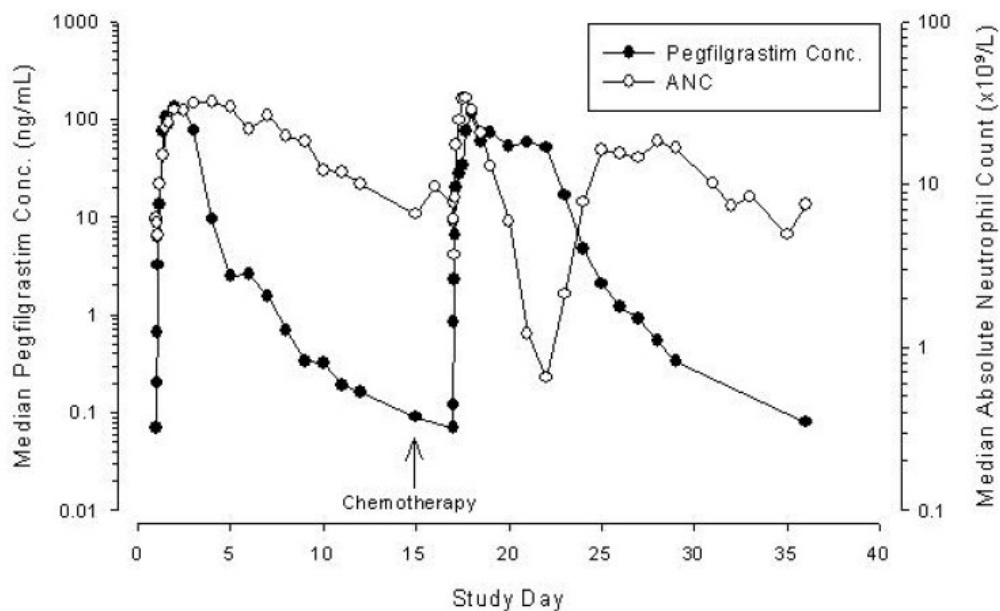

### Special Populations and Conditions

**Pediatrics:** The pharmacokinetic profile in pediatric populations has not been assessed.

**Geriatrics:** No differences were observed in the pharmacokinetics of geriatric patients with cancer ( $\geq 65$  years of age) compared to younger patients ( $< 65$  years of age) (see [7 WARNINGS AND PRECAUTIONS, Special Populations, Geriatrics](#)).

**Sex:** No gender-related differences were observed in the pharmacokinetics of pegfilgrastim.

**Ethnic origin:** The effect of race on pharmacokinetics has not been adequately assessed.

**Hepatic Insufficiency:** The pharmacokinetic profile in patients with hepatic insufficiency has not been assessed.

**Renal Insufficiency:** Renal impairment, including end-stage renal disease, appears to have no effects on the pharmacokinetics of pegfilgrastim.

### 11 STORAGE, STABILITY AND DISPOSAL

Lapelga® (pegfilgrastim) should be stored refrigerated at 2° to 8°C (36° to 46°F). Keep the container in the outer carton to protect from light. Accidental one-time exposure to temperatures up to 30°C or exposure to freezing temperatures (less than 0°C) does not adversely affect the stability of Lapelga®. Freezing should be avoided; however, if accidentally frozen once, Lapelga® should be allowed to thaw in the refrigerator before administration. If exposure has



been greater than 24 hours or frozen more than once, then Lapelga® should not be used.

Within its shelf-life and for the purpose of ambulatory use, Lapelga® can be removed from the refrigerator and left at room temperature (not above 25°C) for a single period of up to 15 days that ends within the labelled expiry date. Once Lapelga® has been out at room temperature it should not be put back into the refrigerator. Any Lapelga® syringes that have been out of the refrigerator for longer than 15 days should not be used and should be disposed of in accordance with local requirements.

Lapelga® should be visually inspected for discolouration and particulate matter before administration. Lapelga® should not be administered if discolouration or particulates are observed.

The pre-filled syringe or autoinjector should be disposed of by placing the entire pre-filled syringe with guard activated or autoinjector into an approved puncture-proof container.

## **12 SPECIAL HANDLING INSTRUCTIONS**

Lapelga® (pegfilgrastim) should not be vigorously shaken. Freezing should be avoided. Store in the carton provided to protect from light.

## PART II: SCIENTIFIC INFORMATION

### 13 PHARMACEUTICAL INFORMATION

#### Drug Substance

Proper name:	pegfilgrastim
Chemical name:	Pegylated recombinant methionyl human granulocyte colony-stimulating factor
Molecular formula and molecular mass:	$\text{CH}_3\text{O}(\text{C}_2\text{H}_4\text{O})_n\text{C}_3\text{H}_6\text{C}_{845}\text{H}_{1338}\text{N}_{223}\text{O}_{243}\text{S}_9$ Pegfilgrastim has a total molecular weight of 39,000 daltons.
Structural formula:	Pegfilgrastim is composed of filgrastim (recombinant methionyl human G-CSF) with a 20,000 dalton polyethylene glycol (PEG) molecule covalently bound to the N-terminal methionine residue. Filgrastim is a 175 amino acid protein manufactured by recombinant DNA technology. Filgrastim is produced by <i>Escherichia coli</i> ( <i>E. coli</i> ) bacteria into which the human G-CSF gene has been inserted. Filgrastim has an amino acid sequence that is identical to the natural sequence predicted by human DNA sequence analysis, except for the addition of an N-terminal methionine necessary for expression in <i>E. coli</i> . Because filgrastim is produced in <i>E. coli</i> , the protein is nonglycosylated and thus differs from G-CSF isolated from a human cell.
Physicochemical properties:	Pegfilgrastim drug substance is a clear and colourless liquid with a pH of $4.0 \pm 0.2$ .

#### Product Characteristics

Lapelga<sup>®</sup> (pegfilgrastim) is a sterile, clear colourless liquid.

### 14 CLINICAL TRIALS

#### 14.4 Clinical Trials – Reference Biologic Drug

Table 5. Summary of patient demographics for clinical trials in specific indication

Study #	Trial design	Dosage, route of administration and duration	Study subjects (n = number)	Mean age (Range) years	Gender
980226	Phase 3, double-blind, randomized, filgrastim controlled	Single SC dose of 100 mcg/kg/day pegfilgrastim or SC dose of 5	310 (154 pegfilgrastim, 156 filgrastim)	50.9 (25-81) pegfilgrastim 51.8 (26-87) filgrastim	306 female, 4 male

		mcg/kg/day filgrastim, up to 4 cycles			
990749	Phase 3, double-blind, randomized, filgrastim controlled	6 mg single dose of pegfilgrastim SC or 5 mcg/kg/day filgrastim, up to 14 days, up to 4 cycles	157 (80 pegfilgrastim, 77 filgrastim)	51.9 (31-75) pegfilgrastim  52.6 (30-74) filgrastim	156 female, 1 male
20010144	Phase 3, double-blind, placebo- controlled, randomized	Pegfilgrastim, 6 mg SC, single dose every 3 weeks, up to 12 weeks	928 (463 pegfilgrastim, 465 placebo)	51.9 (21-88) pegfilgrastim  52.1 (24-76) placebo	99% female

Pegfilgrastim administered as a single SC injection, after each cycle of chemotherapy, has been shown to be safe and effective in reducing neutropenia and associated clinical sequelae in a variety of chemotherapy settings.

Pegfilgrastim has been evaluated in three Phase 3, randomized, double-blind, controlled studies. Results from two active controlled studies (n = 467) conducted in patients with breast cancer undergoing up to 4 cycles of chemotherapy with doxorubicin and docetaxel demonstrated non-inferiority of pegfilgrastim to filgrastim. A clinically and statistically similar reduction in the duration of severe neutropenia (absolute neutrophil count [ANC] < 0.5 x 10<sup>9</sup>/L; WHO grade 4) was seen in patients who received a single injection of pegfilgrastim, either 6 mg fixed dose or 100 mcg/kg, compared with patients who received a mean of 11 daily injections (cycle 1) of filgrastim 5 mcg/kg/day.

The mean (std dev) duration of severe neutropenia in cycle 1 in patients who received a single fixed-dose (6 mg) SC injection of pegfilgrastim (n = 68) was 1.8 (1.4) days compared with 1.6 (1.1) days in patients who received daily injections (range: 7 to 14 injections) of filgrastim (n = 62). The difference in means was 0.18 days (95% CI of -0.23 to 0.61). Durations of severe neutropenia were also comparable between treatment groups in all subsequent cycles. The rate of febrile neutropenia (temperature ≥ 38.2°C with an ANC < 0.5 x 10<sup>9</sup>/L) across all cycles was lower for patients receiving pegfilgrastim (13%) compared to patients receiving filgrastim (20%) (-7% difference; 95% CI of -19% to +5%). A single SC injection of pegfilgrastim per chemotherapy cycle was safe and well tolerated (see [8 ADVERSE REACTIONS](#)).

The third study employed a placebo control and evaluated the effect of pegfilgrastim on the incidence of febrile neutropenia when administered in first and all subsequent cycles of a moderately myelosuppressive chemotherapy regimen, docetaxel administered at 100 mg/m<sup>2</sup> Q3W for 4 cycles, which has been reported to be associated with a febrile neutropenia rate of 10% to 20%.

In this study, 928 patients with metastatic or non-metastatic breast cancer were treated with docetaxel. On day 2 of cycle 1, patients were randomized to receive either a single SC dose of 6 mg of pegfilgrastim or placebo. Patients who received pegfilgrastim in cycle 1 were scheduled

to receive pegfilgrastim in all subsequent cycles. Patients who received placebo in cycle 1 were scheduled to receive placebo in all subsequent cycles; however, patients who experienced febrile neutropenia would receive open-label pegfilgrastim.

The incidence of febrile neutropenia was statistically significantly lower for patients randomized to receive pegfilgrastim versus placebo (1% versus 17%,  $p \leq 0.001$ ). The incidence of hospitalizations and IV anti-infective use associated with a clinical diagnosis of febrile neutropenia was significantly lower in the pegfilgrastim group compared with placebo [1% versus 14%,  $p \leq 0.001$ ; and 2% versus 10%,  $p \leq 0.001$ , respectively (see [Figure 2](#)).

**Figure 2. Percentage of Subjects with Febrile Neutropenia (FN), Who Were Hospitalized, and Who Received IV Anti-infectives for FN**

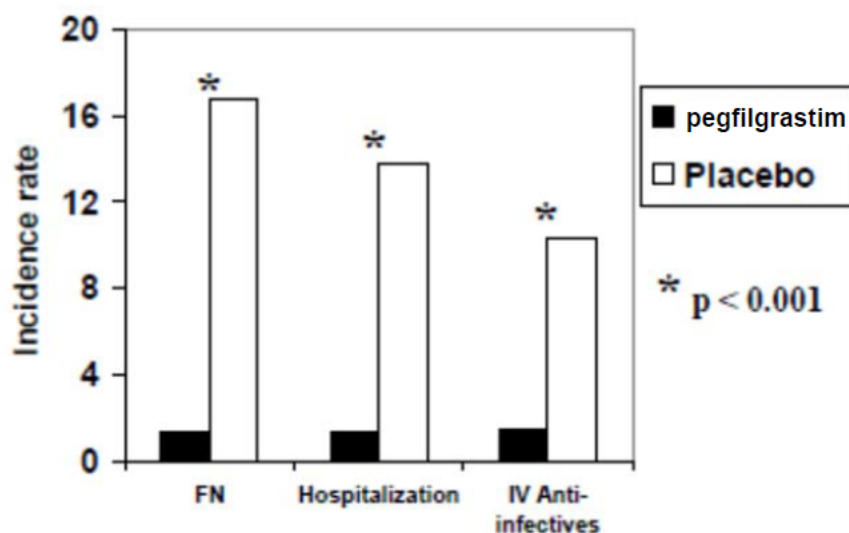

Data from Phase 2 studies in patients with various malignancies undergoing a variety of chemotherapy regimens further support the safety and efficacy of pegfilgrastim. Dose-finding studies in patients with breast cancer ( $n = 152$ ), thoracic tumours ( $n = 92$ ), and non-Hodgkin's lymphoma (NHL) ( $n = 49$ ) demonstrated that the efficacy of a single injection of pegfilgrastim 100 mcg/kg was similar to daily injections of filgrastim 5 mcg/kg/day, and superior to pegfilgrastim doses of 30 or 60 mcg/kg, at reducing the duration of severe neutropenia and the rate of febrile neutropenia. A randomized Phase 2 study of patients with NHL or Hodgkin's lymphoma ( $n = 60$ ) further supports the safety and efficacy of pegfilgrastim.

## 15 MICROBIOLOGY

No microbiology information is required for this drug product.

## 16 NON-CLINICAL TOXICOLOGY

### Preclinical Studies

The preclinical toxicology of pegfilgrastim was studied in Sprague-Dawley® rats and cynomolgus monkeys. A single-dose IV study was conducted in rats. Pegfilgrastim caused no clinical signs or mortality at single IV doses up to 10,000 mcg/kg in rats.

Repeat-dose studies included 2-week SC (every-other-day dosing) and 6-month SC/IV (weekly dosing) studies in rats and a 1-month SC (weekly dosing) study in monkeys. Dosing was intermittent to mimic intended human use of pegfilgrastim. Pegfilgrastim was well tolerated for 6 months at once-weekly doses up to 1000 mcg/kg SC or 300 mcg/kg IV in rats, and for 1 month at once-weekly doses up to 750 mcg/kg SC in cynomolgus monkeys. No effects on body weight, food consumption, or survival were observed. Pegfilgrastim caused an increase in leukocyte counts, primarily segmented neutrophils, but also some increases in band neutrophils, monocytes, and lymphocytes. Pegfilgrastim also modestly decreased erythrocyte counts, hemoglobin and hematocrit levels, decreased serum cholesterol, slightly decreased serum potassium, and increased serum alkaline phosphatase. Splenomegaly was the principal gross pathological finding. Histopathological examination revealed increased neutrophilic granulopoiesis in bone marrow and extramedullary hematopoiesis in spleen, liver, and/or lymph nodes. Leukocytosis in spleen, liver, and lymph nodes, and mild inflammation and mononuclear cell infiltrate at the injection site were additionally observed in monkeys treated with pegfilgrastim. Observed changes tended to reverse upon cessation of treatment. Changes specific to every-other-day dosing in rats ( $\geq 500$  mcg/kg only) included slightly increased serum ALT and/or AST, mild myelofibrosis in bone marrow, and increased osteoblastic/osteoclastic activity in bone. Little or no seroreactivity to pegfilgrastim was evident in rats, whereas a dose and time-dependent increase in seroreactivity was observed in monkeys; however, pegfilgrastim induced neutrophil increases were maintained.

Pegfilgrastim has been shown to have adverse effects in pregnant rabbits when given every other-day at doses as low as 50 mcg/kg. Nonclinical data in pregnant rats indicate that very low levels of pegfilgrastim may cross the placenta.

Pegfilgrastim administered SC to pregnant rabbits at doses of 200 and 250 mcg/kg every-other-day during the period of organogenesis was associated with an increased incidence of abortions. Increased postimplantation loss due to early resorptions and decreased numbers of live fetuses were observed at pegfilgrastim doses of 200 to 1000 mcg/kg every other day. Decreased maternal food consumption and/or weight gain and decreased fetal weight were observed at doses of 50 to 1000 mcg/kg every other day. Pegfilgrastim did not cause visceral or skeletal malformations in rabbit fetuses at doses as high as 200 mcg/kg every-other-day and did not cause external malformations in rabbit fetuses at doses as high as 1000 mcg/kg every other day.

Pegfilgrastim was not associated with an increase in external, visceral, or skeletal malformations in fetuses when administered by SC injection to pregnant rats during the period of organogenesis at dose levels up to 1000 mcg/kg every other day. However, an increased incidence of wavy ribs, generally regarded as a reversible pathological finding, was observed in rat fetuses at dose levels of 300 and 1000 mcg/kg every other day. No maternal or neonatal toxicities were observed in female rats administered once-weekly SC injections of pegfilgrastim up to 1000 mcg/kg in a pre- and postnatal developmental study.

Filgrastim is known to be negative in bacterial mutagenesis assays (Ames assay). Pegfilgrastim did not cause precancerous or cancerous lesions in Sprague-Dawley® rats after once-weekly SC injections of up to 1000 mcg/kg for 6 months. Given the similar biochemical activity to filgrastim, the chemical nature of the PEG moiety, and extensive clinical experience with

filgrastim, it is considered unlikely that pegfilgrastim would be carcinogenic when used as directed.

Pegfilgrastim is a growth factor that primarily stimulates production of neutrophils and neutrophil precursors; however, the G-CSF receptor through which pegfilgrastim and filgrastim act has been found on tumour cell lines, including some myeloid, T-lymphoid, lung, head and neck, and bladder tumour cell lines. *In vitro* proliferation has been observed in response to filgrastim in some of these cell lines, particularly acute myeloid leukemia (AML) cell lines.

Indices of mating or fertility in male and female Sprague-Dawley® rats were not adversely affected by once-weekly SC injections of pegfilgrastim of up to 1000 mcg/kg for 2 to 4 weeks before and during cohabitation.

## **17 SUPPORTING PRODUCT MONOGRAPHS**

Neulasta Solution for Injection, 6 mg (10 mg/mL), Submission Control No: 242732, Product Monograph, Amgen Canada Inc. (January 8, 2021).

Neulasta is a registered trademark of Amgen Inc.

## PATIENT MEDICATION INFORMATION

### READ THIS FOR SAFE AND EFFECTIVE USE OF YOUR MEDICINE

#### **Pr**LAPELGA® (pronounced) La-pel'-gah pegfilgrastim Injection

#### Single-use Pre-filled Syringe

Read this carefully before you start taking **Lapelga**® and each time you get a refill. This leaflet is a summary and will not tell you everything about this drug. Talk to your healthcare professional about your medical condition and treatment and ask if there is any new information about **Lapelga**®.

**Lapelga**® is a biosimilar biologic drug (biosimilar) to the reference biologic drug Neulasta. A biosimilar is authorized based on its similarity to a reference biologic drug that was already authorized for sale.

#### **Serious Warnings and Precautions**

- Your spleen may become enlarged and can rupture while taking **Lapelga**®. A ruptured spleen can cause death. Call your doctor right away if you have pain in the left upper stomach area or left shoulder tip area.
- If you have a sickle cell trait or sickle cell disease, make sure that you tell your doctor before you start taking **Lapelga**® so that the potential risks and benefits can be discussed. In patients with sickle cell trait or sickle cell disease, severe sickle cell crises have been associated with the use of pegfilgrastim. Severe sickle cell crises, in some cases resulting in death, have also been associated with filgrastim, the parent compound of pegfilgrastim.

#### **What is **Lapelga**® used for?**

**Lapelga**® is used to treat neutropenia (nu-tro-**peen**-ee-ah). Neutropenia is a condition where the body makes too few white blood cells and which may be caused by drugs used to treat cancer. Neutropenia is the most serious common side-effect of chemotherapy. Neutropenia predisposes your body to infections and prevents you from fighting them. Your doctor has decided to prescribe **Lapelga**® for you to increase the number of neutrophils (**nu**-tro-fils), which will fight infections.

**Lapelga**® is a man-made, long-acting form of granulocyte colony-stimulating factor (G-CSF), a substance naturally produced by the body.

#### **How does **Lapelga**® work?**

**Lapelga**® works by stimulating the bone marrow to make white blood cells. To make sure **Lapelga**® is working, your doctor may ask that you have regular blood tests to count the number of white blood cells. It is important to follow the doctor's instructions about these tests.

#### **What are the ingredients in **Lapelga**®?**

Medicinal ingredients: pegfilgrastim

Non-medicinal ingredients: polysorbate 20, sodium acetate, sorbitol, and water for injection.

The Lapelga<sup>®</sup> syringe plunger stopper and needle cover are not made with natural rubber latex.

**Lapelga<sup>®</sup> comes in the following dosage forms:**

A single-use pre-filled syringe containing 6 mg per 0.6 mL of pegfilgrastim active substance with a BD UltraSafe Plus™ Passive Needle Guard. Each blister packaged syringe is provided in a carton.

**Do not use Lapelga<sup>®</sup> if you are:**

- allergic to pegfilgrastim, filgrastim, any of the ingredients of Lapelga<sup>®</sup>
- allergic to other products made using the bacteria *Escherichia coli*. Talk to your doctor if you have any questions about this information.

**To help avoid side effects and ensure proper use, talk to your healthcare professional before you take Lapelga<sup>®</sup>. Talk about any health conditions or problems you may have, including:**

- If you have common signs of infection, such as fever, chills, rash, sore throat, diarrhea, or redness, swelling, or pain around a cut or sore. If you notice any of these symptoms during treatment with Lapelga<sup>®</sup>, tell your doctor or nurse immediately. Lapelga<sup>®</sup> can reduce the risk of infection, but it may not prevent all infections. An infection can still happen during the short time when your white blood cell levels are low.
- If there is a lump, swelling, or bruising at the injection site that does not go away, talk to your doctor. Occasionally a problem may develop at the injection site.
- If you have sickle cell trait or sickle cell disease, tell your doctor prior to treatment. If you develop left upper abdominal pain or pain at the tip of your shoulder, tell your doctor or nurse immediately.

**Other warnings you should know about:**

Your doctor will decide if you are able to give yourself a subcutaneous (i.e., under the skin) injection. Lapelga<sup>®</sup> should only be injected on the day the doctor has determined for you, and should not be injected until 24 hours after receiving your last dose of chemotherapy in each cycle.

(If you are injecting someone else with Lapelga<sup>®</sup>, it is important that you inform yourself about Lapelga<sup>®</sup> to know how and when to give the Lapelga<sup>®</sup> injection.)

Make sure your doctor knows about all medications you are taking before starting Lapelga<sup>®</sup> injections. Patients taking lithium may need more frequent blood tests.

More information about Lapelga<sup>®</sup> is available in the Product Monograph. Any questions should be discussed with your doctor.

**Pregnancy or breast feeding and Lapelga<sup>®</sup>**

Lapelga<sup>®</sup> has not been studied in pregnant women, and its effects on developing babies are not known. It is possible that Lapelga<sup>®</sup> can get into human breast milk. If you are pregnant, plan to become pregnant, think you may be pregnant, or are breast feeding, you should consult your doctor before using Lapelga<sup>®</sup>.

**Tell your healthcare professional about all the medicines you take, including any drugs, vitamins, minerals, natural supplements or alternative medicines.**



**The following may interact with Lapelga®:**

Drug interactions between Lapelga® and other drugs have not been studied. Drugs such as lithium may affect the release of neutrophils into the blood stream. Patients taking lithium may need more frequent blood tests. You should discuss your treatment with your doctor before using Lapelga®.

**How to take Lapelga®:****Usual dose:**

The recommended dose of Lapelga® is a single subcutaneous injection, just under the skin, of 6 mg (the contents of one pre-filled syringe), administered once per cycle of chemotherapy. You must wait at least 24 hours after your course of cancer chemotherapy before injecting Lapelga®.

**Overdose:**

If you think you, or a person you are caring for, have taken too much Lapelga®, contact a healthcare professional, hospital emergency department or regional poison control centre immediately, even if there are no symptoms.

**Missed Dose:**

As there should be a two-week period between Lapelga® and your next course of cancer chemotherapy, if you miss a planned dose, consult your doctor before taking the missed dose.

**Information on how to inject Lapelga®**

This section contains information on how to give yourself an injection of Lapelga®. **It is important that you get special training from your doctor or nurse before you give yourself the injection.** If you are not sure about giving yourself the injection or you have any questions, please ask your doctor or nurse for help. **If you are giving Lapelga® to someone else, it is important that you know how to inject Lapelga®.**

Lapelga® is provided in a single-use pre-filled syringe with a BD UltraSafe Plus™ Passive Needle Guard. The needle guard is a protective mechanism which can prevent syringe re-use and accidental needle-pricks after Lapelga® has been injected. **Lapelga® should be stored in its carton to protect from light until use.**

Before taking the Lapelga® injection, always check that:

- The name Lapelga® appears on the carton, blister and syringe label.
- The expiration date on the label has not passed. **You should not use a pre-filled syringe after the expiry date (see EXP) on the label.**
- The Lapelga® liquid should always be clear and colorless. Do not use Lapelga® if the contents of the pre-filled syringe appear discolored or cloudy, or if the pre-filled syringe appears to contain lumps, flakes, or particles.

**Important: To help avoid possible infection, you should follow these instructions exactly.**

**Before Injecting Lapelga®**

1. To give yourself a subcutaneous injection assemble your supplies of:
  - Lapelga<sup>®</sup> pre-filled syringe which has a plunger and a transparent (clear) plastic needle guard attached as shown in the image below:

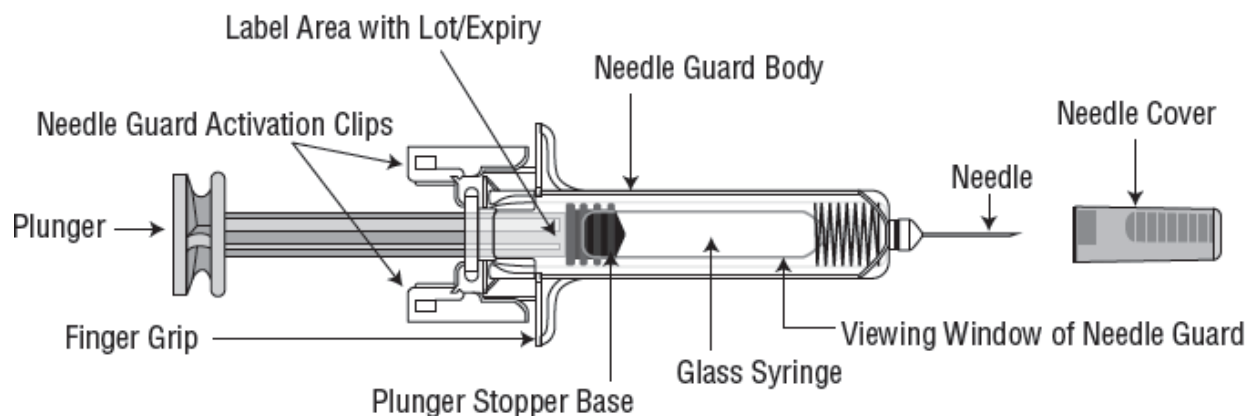

- Alcohol wipes or similar.
- Cotton ball or gauze.
- Puncture-proof container for disposing of used syringes, as discussed with your doctor/nurse.

### Setting up for an Injection

**Note: The Lapelga<sup>®</sup> syringe plunger stopper and needle cover are not made with natural rubber latex.**

1. Remove the carton containing the Lapelga<sup>®</sup> pre-filled syringe in the blister packaging from the refrigerator and leave it unopened on your working surface for about 30 minutes so that it reaches room temperature. **Avoid warming Lapelga<sup>®</sup> in any other way.**
2. Check the expiry date which is stated on the carton, blister and syringe label (see EXP). Do not use it if the date has passed the last day of the month shown.
3. Do not shake the pre-filled syringe as vigorous shaking may damage the medication. If the pre-filled syringe has been shaken vigorously, the solution may appear foamy and it should not be used. Check the appearance of Lapelga<sup>®</sup>. It must be clear. If it is cloudy or there are particles in it, you must not use it.
4. Clean your hands thoroughly with soap and water and/or hand sanitizer.
5. Find a comfortable, well-lit place and put the syringe, the alcohol wipes, the cotton ball or gauze and the puncture-proof container where you can reach them.
6. Keep the needle cover on the needle until you are ready to inject.

## Choose an injection site

You will need to give yourself an injection into the tissue under the skin, known as a subcutaneous injection. Your doctor or nurse will tell you how frequently it should be injected. If you miss a dose, contact your doctor or nurse.

The most suitable injection sites (places on your body) to inject Lapelga® are:

- The outer area of your upper arms
- The front of your middle thighs
- The abdomen, **except for the 2 inches area around the navel**
- Upper outer area of your buttocks

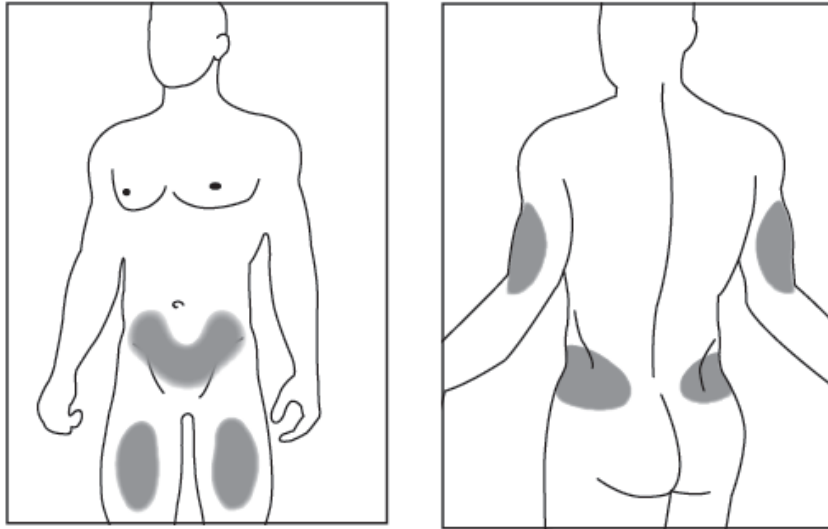

From the above options, change the injection site each time you take an injection so that you do not develop soreness in one area. Do not inject into the same site that is tender, red, bruised or hard or that has scars or stretch marks.

## How do I give my injection?

### **IMPORTANT:** REMOVAL OF INDIVIDUAL SYRINGE FROM BLISTER PACKAGING

Follow directions for correct handling technique as shown below when removing the pre-filled syringe with the BD UltraSafe Plus™ Passive Needle Guard from the packaging, otherwise, the needle's safety mechanism may be triggered, making the syringe unusable.

**IMPORTANT:** If you drop the syringe onto a hard surface, do not use it. Use a new pre-filled syringe.

1. Clean your hands thoroughly with soap and water.



2. Locate the end of the blister packaging with the stripe as indicated by the 2 arrows and “Peel Here” on the top layer. From this end, open the blister pack by peeling back the top layer **COMPLETELY OFF**.

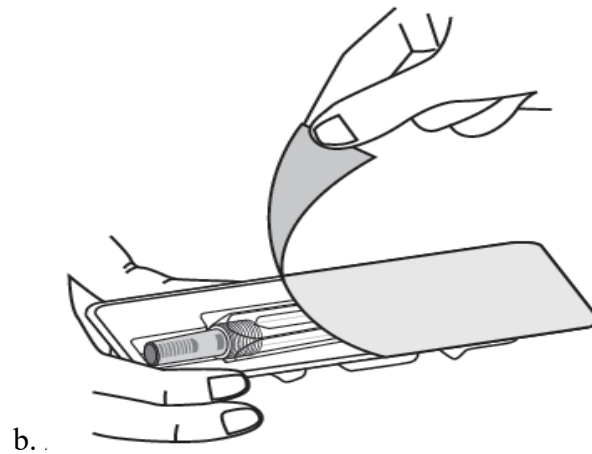
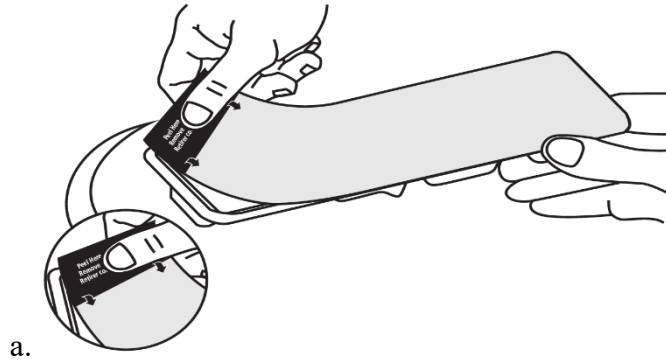

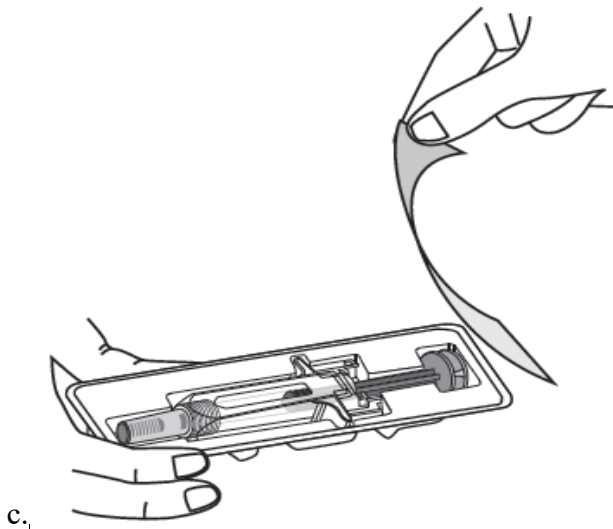

3. Remove the syringe from the blister pack **by the body** as shown below. **Do not** lift the product by the plunger or needle cover. **Do not** touch the needle guard activation clips at any time during use. This may trigger the needle's safety mechanism causing the needle to retract (pull back) before your injection is given. This will make the syringe unusable.

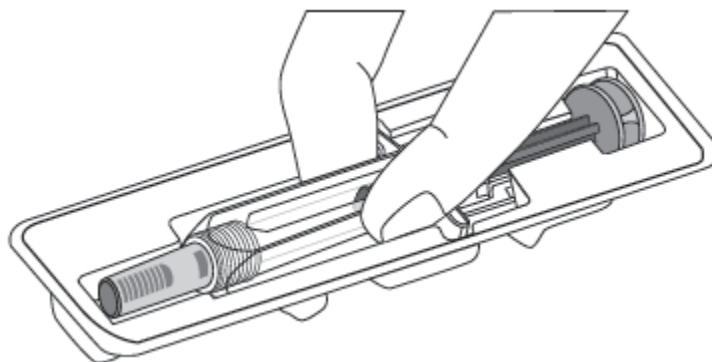

4. Hold the pre-filled syringe by the body (needle guard) with the needle pointing up and avoid touching the needle guard activation clips. Holding the syringe by the body with the needle pointing up helps to prevent the medicine from leaking out of the needle. **Carefully pull the needle cover straight off without twisting it. Do not touch the needle or plunger. Do not use if the syringe is damaged or needle is bent.** If the syringe is damaged or needle is bent, throw away (dispose of) the syringe in the puncture-proof container. Use a new pre-filled syringe.

**If you drop the syringe onto a hard surface, do not use it.** Use a new pre-filled syringe.

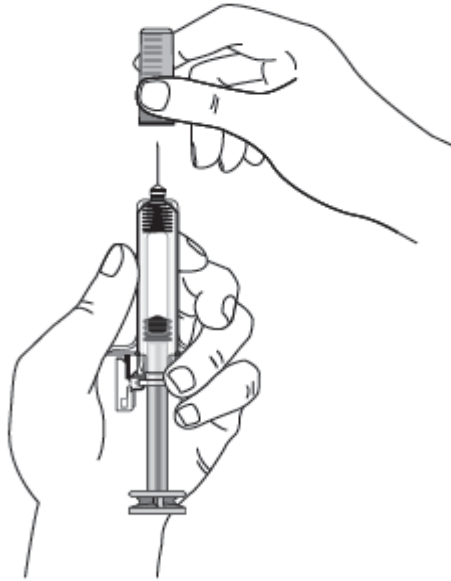

5. Do not push the plunger on the syringe before injection. This may trigger the needle's safety mechanism causing the needle to retract (pull back) before your injection is given. If any liquid is accidentally expelled from the syringe do not use that pre-filled syringe. Dispose of that syringe in the puncture-proof container. Use a new pre-filled syringe.
6. Choose an injection site. (Abdomen or thigh if a patient is injecting himself/herself, with the additional option of the back of the arm if a Healthcare Provider or caregiver is assisting them).

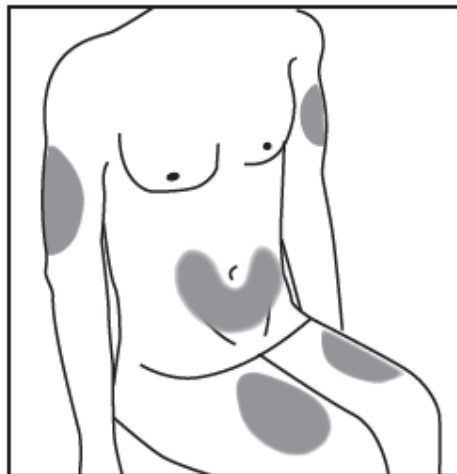

7. Before you inject Lapelga<sup>®</sup>, you must **always clean** the skin on the selected injection site by using an alcohol wipe.

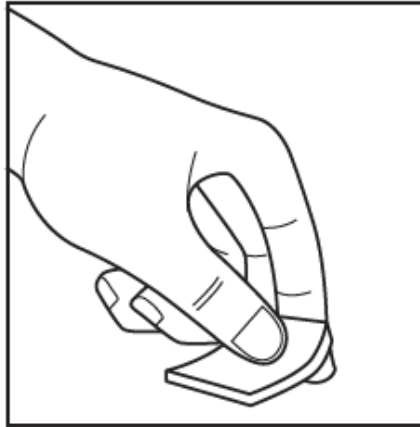

8. Hold the pre-filled syringe between the thumb and forefinger of the hand you will use to inject Lapelga<sup>®</sup>. Use the other hand to pinch a fold of the skin at the cleaned injection site between your thumb and forefinger, without squeezing it as shown below.

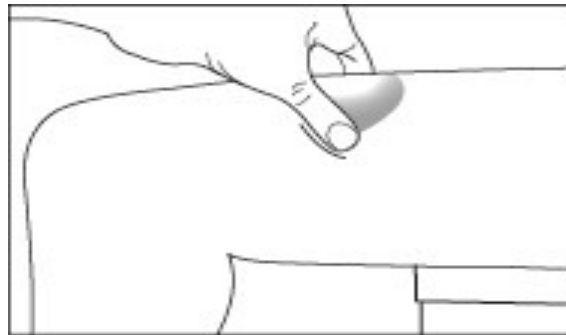

9. Insert the needle into the skin at an angle greater than or equal to 45° as shown by your doctor or nurse and the image below.

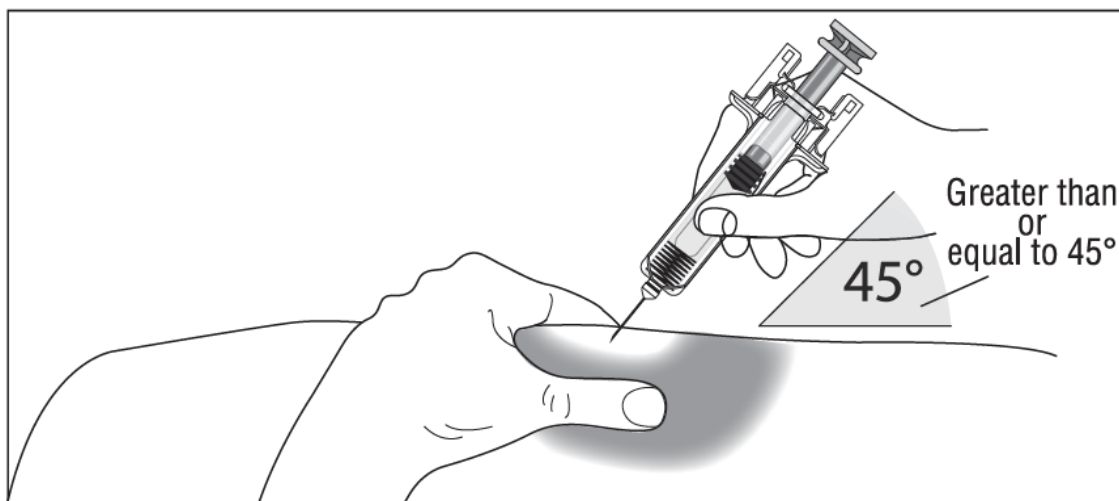

10. After the needle is inserted, let go of pinching on the fold of the skin. Inject the prescribed dose subcutaneously by pushing the plunger with your thumb while grasping the finger grips

as shown in the image below and as directed by your doctor or nurse.

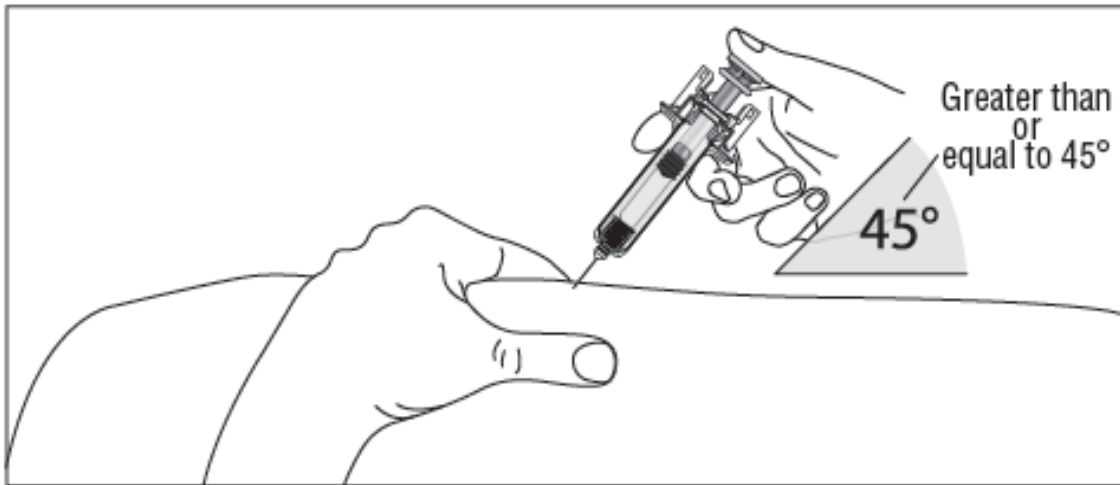

11. Press the plunger slowly and completely, until all of the medication has been injected as shown below. The needle guard will not be activated unless the entire dose has been administered and you remove downward pressure on the plunger.

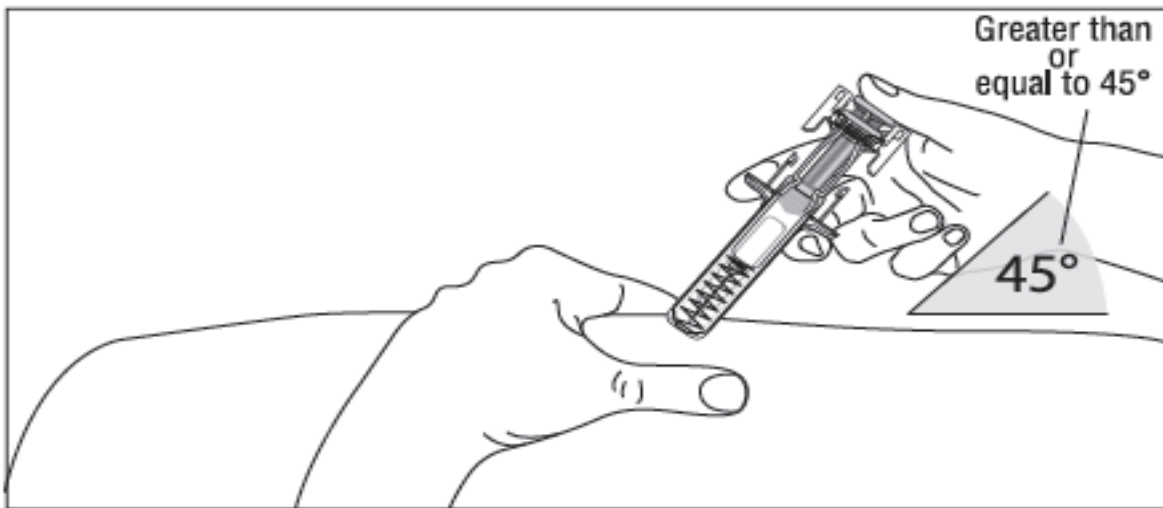

12. When the syringe is emptied of all the medication, slowly lift your thumb from the plunger which will release the needle guard. The needle will then withdraw from the skin and be covered and locked in place by the needle guard.



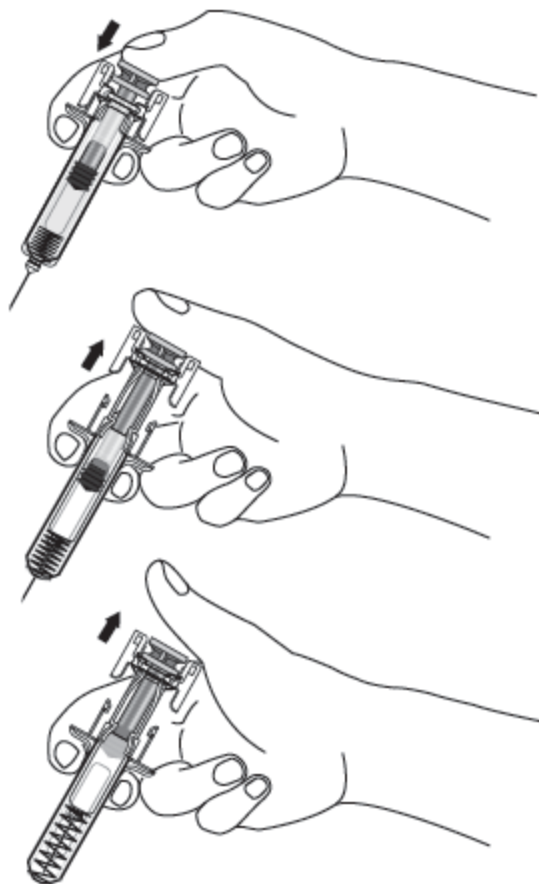

13. After the injection, immediately place cotton or gauze on the injection site and apply pressure for several seconds. Do not use Lapelga<sup>®</sup> that is left in the syringe.
14. Place the pre-filled syringe with the needle guard covered needle into a puncture-proof container for proper disposal as described below. Use each pre-filled syringe for only one injection.

### **Remember**

Do not hesitate to consult your doctor or nurse for help or if you have any concerns.

### **Disposal of Used Syringes**

The used syringes should be disposed of in accordance with local requirements.

- Put used syringes into an appropriate puncture-proof container as instructed by your doctor/nurse.
- **Always** keep this container **out of reach and sight of children**.
- When the puncture-proof container is full, it should be disposed as instructed by your doctor, nurse or pharmacist. **Do not throw the container in the household trash. Do not recycle.**
- Never put used syringes into your normal household waste bin.

### **What are possible side effects from using Lapelga<sup>®</sup>?**

These are not all the possible side effects you may feel when taking Lapelga®. If you experience any side effects not listed here, contact your healthcare professional.

- **Spleen Rupture.** Your spleen may become enlarged and can rupture while taking Lapelga®. A ruptured spleen can cause death. The spleen is located in the upper left section of your stomach area. Call your doctor right away if you have pain in the left upper stomach area or left shoulder tip area. This pain could mean your spleen is enlarged or ruptured.
- **Serious Allergic Reactions.** Serious allergic reactions can also happen. These reactions may cause a rash over the whole body, shortness of breath, wheezing, a drop in blood pressure (usually causing dizziness or lightheadedness), swelling around the mouth or eyes, fast pulse, or sweating. If you experience an allergic reaction during the injection of Lapelga®, the injection should be stopped immediately. **If at any time a serious allergic reaction occurs, immediately call a doctor or emergency services (for example, call 911).**
- **A serious lung problem called acute respiratory distress syndrome (ARDS).** Call your doctor or seek emergency care right away if you have shortness of breath, trouble breathing or a fast rate of breathing.
- **Kidney injury (glomerulonephritis)** has been seen in patients who received pegfilgrastim. Call your doctor immediately if you experience puffiness in your face or ankles, blood in your urine or brown coloured urine, or if you notice that you urinate less often than usual.

**What are the most common side effects of Lapelga®?**

The most common side effect that you may experience is aching in the bones and muscles. If this occurs, it can usually be relieved with a non-acetylsalicylic acid over-the-counter pain reliever. Ask your doctor which is the most suitable one for you.

Some patients experience redness, swelling, or itching at the site of injection. This may be an allergy to the ingredients in Lapelga®, or it may be a local reaction. If you notice any of these signs or symptoms, call your doctor.

Serious side effects and what to do about them			
Symptom / effect	Talk to your healthcare professional		Stop taking drug and get immediate medical help
	Only if severe	In all cases	
<b>VERY COMMON ≥ 10%</b>			
Bone Pain		√	
<b>UNCOMMON ≥ 0.1% and &lt; 1%</b>			
Low platelet counts (thrombocytopenia) (including the following symptoms: easy bruising and increased bleeding).		√	

Allergic reactions (including the following symptoms: rash over the whole body, shortness of breath, a drop in blood pressure (usually causing dizziness or lightheadedness), swelling around the mouth or eyes, fast pulse, weakness, sweating; severe redness or swelling or itching at injection site).		√	√
Acute respiratory distress syndrome (including the following symptoms: fever, shortness of breath, cough, or congestion in your lungs).		√	√
<b>VERY RARE &lt; 0.01%</b>			
Splenomegaly (including the following symptoms: pain in the left upper stomach area or left shoulder tip area).		√	
<b>*FREQUENCY NOT KNOWN</b>			
Splenic rupture (including the following symptoms: left upper abdominal pain or pain at the tip of your shoulder).		√	
Cutaneous Vasculitis (including the following symptoms: A rash in the skin surface that looks like purple or red spots or bumps, clusters of small dots, splotches or hives. Your skin may also be itchy).		√	
Capillary Leak Syndrome (including the following symptoms: swelling or puffiness, which may be associated with passing water less frequently, difficulty breathing, abdominal swelling and feeling of fullness, and a general feeling of tiredness).		√	
Kidney Injury (glomerulonephritis) (including the following symptoms: puffiness in the face or ankles, blood in urine or brown coloured urine, or urinating less often than usual).		√	√
**Abnormal number of immature bone marrow cells (myelodysplastic syndrome) that could lead to a type of cancer (acute myeloid leukemia) (including the following symptoms: fever, bone pain, bruising, difficulty breathing, bleeding and a general feeling of tiredness).		√	√

\* Reported in the post-marketing setting where the incidence is not known.

\*\* Adverse events in breast and lung cancer patients receiving chemotherapy and/or radiotherapy.

If you have a troublesome symptom or side effect that is not listed here or becomes bad enough to interfere with your daily activities, talk to your healthcare professional.

### Reporting Side Effects

You can report any suspected side effects associated with the use of health products to Health Canada by:

- Visiting the Web page on Adverse Reaction Reporting (<https://www.canada.ca/en/health-canada/services/drugs-health-products/medeffect-canada.html>) for information on how to report online, by mail or by fax; or
- Calling toll-free at 1-866-234-2345.

*NOTE: Contact your health professional if you need information about how to manage your side effects. The Canada Vigilance Program does not provide medical advice.*

### Storage:

- Lapelga<sup>®</sup> should be stored in the refrigerator at 2° to 8°C (36° to 46°F). Freezing should be avoided. Avoid shaking Lapelga<sup>®</sup>.
- If accidentally frozen, allow Lapelga<sup>®</sup> to thaw in the refrigerator before injecting. However, if frozen a second time, DO NOT use it and contact your doctor or nurse for further instructions.
- Lapelga<sup>®</sup> can be removed from the refrigerator and left at room temperature (not above 25°C) for a single period of up to 15 days that ends within the labelled expiry date. Once Lapelga<sup>®</sup> has been out at room temperature it should not be put back into the refrigerator. Any Lapelga<sup>®</sup> syringes that have been out of the refrigerator for longer than 15 days should not be used and should be disposed of in accordance with local requirements.
- Lapelga<sup>®</sup> should be protected from light, so you should keep it in its carton until you are ready to use it. Avoid leaving Lapelga<sup>®</sup> in direct sunlight.

For any questions about storage, contact your doctor or nurse.

Keep out of reach and sight of children.

### If you want more information about Lapelga<sup>®</sup>:

- Talk to your healthcare professional
- Find the full product monograph that is prepared for healthcare professionals and includes this Patient Medication Information by visiting the Health Canada website (<https://www.canada.ca/en/health-canada/services/drugs-health-products/drug-products/drug-product-database.html>). Find the Patient Medication Information on the manufacturer's website at: <http://www.apotex.ca/products>, or by contacting DISpedia Apotex's Drug Information Service at: 1-800-667-4708.

This leaflet was prepared by Apotex Inc., Toronto, Ontario, M9L 1T9.

BD UltraSafe Plus<sup>™</sup> Passive is a trademark of Becton, Dickinson and Company.

Last Revised:

## PATIENT MEDICATION INFORMATION

### READ THIS FOR SAFE AND EFFECTIVE USE OF YOUR MEDICINE

**Pr****LAPELGA**<sup>®</sup> (pronounced) La-pel'-gah

#### **pegfilgrastim Injection**

#### **Single-use Pre-filled Autoinjector**

Read this carefully before you start taking **Lapelga**<sup>®</sup> and each time you get a refill. This leaflet is a summary and will not tell you everything about this drug. Talk to your healthcare professional about your medical condition and treatment and ask if there is any new information about **Lapelga**<sup>®</sup>.

**Lapelga**<sup>®</sup> is a biosimilar biologic drug (biosimilar) to the reference biologic drug Neulasta. A biosimilar is authorized based on its similarity to a reference biologic drug that was already authorized for sale.

#### **Serious Warnings and Precautions**

- Your spleen may become enlarged and can rupture while taking **Lapelga**<sup>®</sup>. A ruptured spleen can cause death. Call your doctor right away if you have pain in the left upper stomach area or left shoulder tip area.
- If you have a sickle cell trait or sickle cell disease, make sure that you tell your doctor before you start taking **Lapelga**<sup>®</sup> so that the potential risks and benefits can be discussed. In patients with sickle cell trait or sickle cell disease, severe sickle cell crises have been associated with the use of pegfilgrastim. Severe sickle cell crises, in some cases resulting in death, have also been associated with filgrastim, the parent compound of pegfilgrastim.

#### **What is **Lapelga**<sup>®</sup> used for?**

**Lapelga**<sup>®</sup> is used to treat neutropenia (nu-tro-**peen**-ee-ah). Neutropenia is a condition where the body makes too few white blood cells and which may be caused by drugs used to treat cancer. Neutropenia is the most serious common side-effect of chemotherapy. Neutropenia predisposes your body to infections and prevents you from fighting them. Your doctor has decided to prescribe **Lapelga**<sup>®</sup> for you to increase the number of neutrophils (**nu**-tro-fils), which will fight infections.

**Lapelga**<sup>®</sup> is a man-made, long-acting form of granulocyte colony-stimulating factor (G-CSF), a substance naturally produced by the body.

#### **How does **Lapelga**<sup>®</sup> work?**

**Lapelga**<sup>®</sup> works by stimulating the bone marrow to make white blood cells. To make sure **Lapelga**<sup>®</sup> is working, your doctor may ask that you have regular blood tests to count the number of white blood cells. It is important to follow the doctor's instructions about these tests.

### **What are the ingredients in Lapelga®?**

Medicinal ingredients: pegfilgrastim

Non-medicinal ingredients: polysorbate 20, sodium acetate, sorbitol, and water for injection.

The needle cover on the pre-filled autoinjector is not made with natural rubber latex.

### **Lapelga® comes in the following dosage forms:**

A single-use pre-filled autoinjector containing 6 mg per 0.6 mL of pegfilgrastim active substance. Each pre-filled autoinjector is provided in a carton.

### **Do not use Lapelga® if you are:**

- allergic to pegfilgrastim, filgrastim, any of the ingredients of Lapelga®,
- allergic to other products made using the bacteria *Escherichia coli*. Talk to your doctor if you have any questions about this information.

### **To help avoid side effects and ensure proper use, talk to your healthcare professional before you take Lapelga®. Talk about any health conditions or problems you may have, including:**

- If you have common signs of infection, such as fever, chills, rash, sore throat, diarrhea, or redness, swelling, or pain around a cut or sore. If you notice any of these symptoms during treatment with Lapelga®, tell your doctor or nurse immediately. Lapelga® can reduce the risk of infection, but it may not prevent all infections. An infection can still happen during the short time when your white blood cell levels are low.
- If there is a lump, swelling, or bruising at the injection site that does not go away, talk to your doctor. Occasionally a problem may develop at the injection site.
- If you have sickle cell trait or sickle cell disease, tell your doctor prior to treatment. If you develop left upper abdominal pain or pain at the tip of your shoulder, tell your doctor or nurse immediately.

### **Other warnings you should know about:**

Your doctor will decide if you are able to give yourself a subcutaneous (i.e., under the skin) injection. Lapelga® should only be injected on the day the doctor has determined for you, and should not be injected until 24 hours after receiving your last dose of chemotherapy in each cycle.

If you are injecting someone else with Lapelga®, it is important that you inform yourself about Lapelga® to know how and when to give the Lapelga® injection.

Make sure your doctor knows about all medications you are taking before starting Lapelga® injections. Patients taking lithium may need more frequent blood tests.

More information about Lapelga® is available in the Product Monograph. Any questions should be discussed with your doctor.

### **Pregnancy or breast feeding and Lapelga®**

Lapelga® has not been studied in pregnant women, and its effects on developing babies are not known. It is possible that Lapelga® can get into human breast milk. If you are pregnant, plan to become pregnant, think you may be pregnant, or are breast feeding, you should consult your doctor before using Lapelga®.

**Tell your healthcare professional about all the medicines you take, including any drugs, vitamins, minerals, natural supplements or alternative medicines.**

**The following may interact with Lapelga®:**

Drug interactions between Lapelga® and other drugs have not been studied. Drugs such as lithium may affect the release of neutrophils into the blood stream. Patients taking lithium may need more frequent blood tests. You should discuss your treatment with your doctor before using Lapelga®.

**How to take Lapelga®:**

**Usual dose:**

The recommended dose of Lapelga® is a single subcutaneous injection, just under the skin, of 6 mg (the contents of one pre-filled autoinjector), administered once per cycle of chemotherapy. You must wait at least 24 hours after your course of cancer chemotherapy before injecting Lapelga®.

**Overdose:**

If you think you, or a person you are caring for, have taken too much Lapelga®, contact a healthcare professional, hospital emergency department or regional poison control centre immediately, even if there are no symptoms.

**Missed Dose:**

As there should be a two-week period between Lapelga® and your next course of cancer chemotherapy, if you miss a planned dose, consult your doctor before taking the missed dose.

**Information on how to inject Lapelga®**

This section contains information on how to give yourself an injection of Lapelga®. **It is important that you get special training from your doctor or nurse before you give yourself the injection.** If you are not sure about giving yourself the injection or you have any questions, please ask your doctor or nurse for help. **If you are giving Lapelga® to someone else, it is important that you know how to inject Lapelga®.**

Lapelga® is provided in a single-use pre-filled autoinjector. The autoinjector was designed to allow for simplified and accurate dose delivery making dose administration easier. **Lapelga® should be stored in its carton to protect from light until use.**

Before taking the Lapelga® injection, always check that:

- The name Lapelga® appears on the carton and pre-filled autoinjector label.
- The expiration date on the label has not passed. **You should not use a pre-filled autoinjector after the expiry date (see EXP) on the label.**
- The Lapelga® liquid should always be clear and colorless. Do not use Lapelga® if the contents of the pre-filled autoinjector appear discolored or cloudy, or if the pre-filled autoinjector appears to contain lumps, flakes, or particles.



**Important: To help avoid possible infection, you should follow these instructions exactly.**

### **Before Injecting Lapelga®**

1. To give yourself a subcutaneous injection assemble your supplies of:

- Lapelga® pre-filled autoinjector.

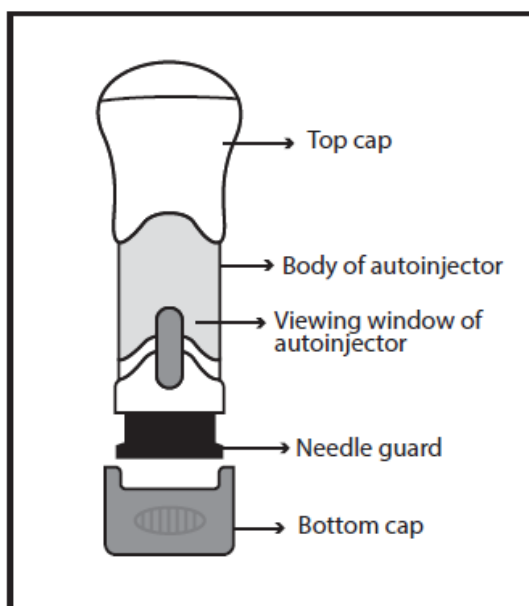

- Alcohol wipes or similar.
- Cotton ball or gauze.
- Puncture-proof container for disposing of used syringes/autoinjectors, as discussed with your doctor/nurse.

### **Setting up for an Injection**

**Note: The needle cover on the single-use pre-filled autoinjector is not made with natural rubber latex.**

1. Remove the carton containing the Lapelga® pre-filled autoinjector from the refrigerator and leave it unopened on your working surface for about 30 minutes so that it reaches room temperature. **Avoid warming Lapelga® in any other way.**
2. Check the expiry date which is stated on the carton and autoinjector label (see EXP). Do not use it if the date has passed the last day of the month shown.
3. Do not shake the pre-filled autoinjector as vigorous shaking may damage the medication. If the pre-filled autoinjector has been shaken vigorously, the solution may appear foamy and it should not be used. Condensation may appear on the viewing window due to refrigeration. Wipe away the condensation so you can check the appearance of Lapelga®. It must be clear. If it is cloudy or there are particles in it, you must not use it.

4. Clean your hands thoroughly with soap and water and/or hand sanitizer.
5. Find a comfortable, well-lit place and put the autoinjector, the alcohol wipes, the cotton ball or gauze and the puncture-proof container where you can reach them.
6. Keep the bottom cap on the autoinjector until you are ready to inject.

### Choose an injection site

You will need to give yourself an injection into the tissue under the skin, known as a subcutaneous injection. Your doctor or nurse will tell you how frequently it should be injected. If you miss a dose, contact your doctor or nurse.

The most suitable injection sites (places on your body) to inject Lapelga<sup>®</sup> are:

- The outer area of your upper arms
- The front of your middle thighs
- The abdomen, **except for the 2 inches area around the navel**

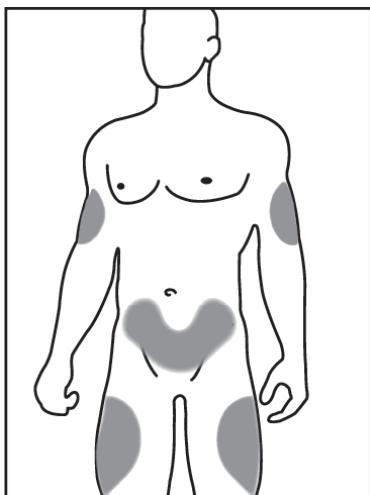

From the above options, change the injection site each time you take an injection so that you do not develop soreness in one area. Do not inject into the same site that is tender, red, bruised or hard or that has scars or stretch marks.

### How do I give my injection?

1. Clean your hands thoroughly with soap and water.

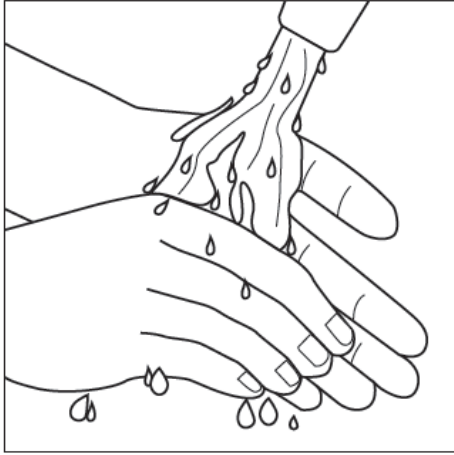

2. Choose an injection site. (Abdomen or thigh if a patient is injecting himself/herself, with the additional option of the back of the arm if a Healthcare Provider or caregiver is assisting them)

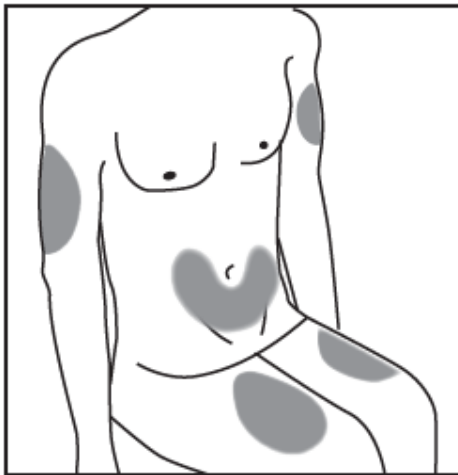

3. Before you inject Lapelga® you must **always clean** the skin on the selected injection site by using an alcohol wipe.

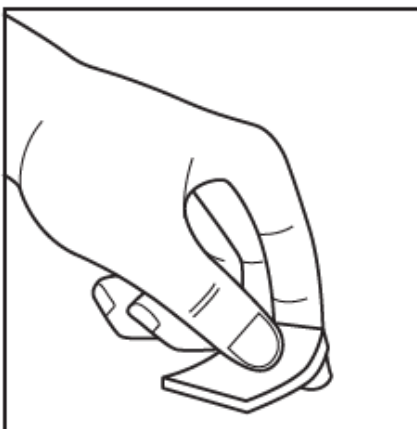

4. Remove the autoinjector from the tray **by the body** as shown below.

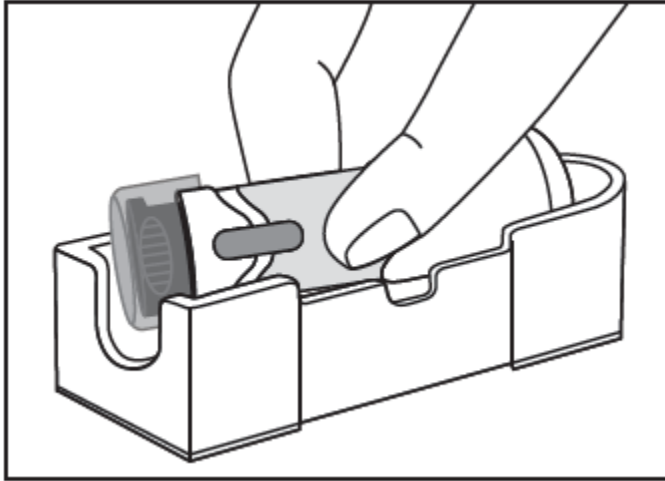

5. Inspect liquid in window. Condensation may appear on the viewing window due to refrigeration. Wipe away the condensation so you can check the appearance of Lapelga®. It must be clear. If it is cloudy or there are particles in it, you must not use it.

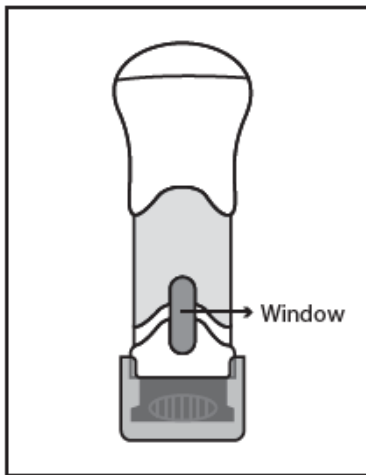

6. Remove bottom cap: Twist and pull bottom cap to remove. Keep hands away from needle guard after cap is removed. Do not recap. Dispose of bottom cap immediately. Do not inject if you drop the pre-filled autoinjector after removing cap.

Inject within 5 minutes of removing bottom cap.

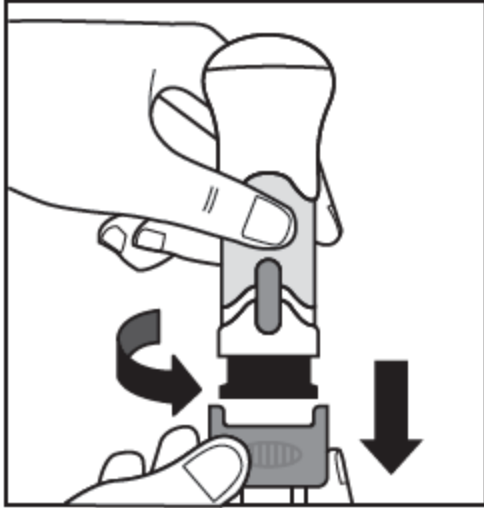

7. Place the autoinjector straight onto your skin (about 90 degrees).

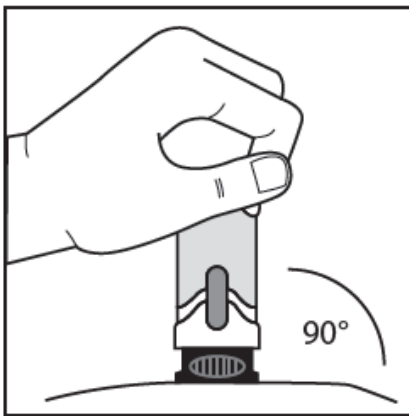

8. Push the handle straight down: The medicine will be injected as you push. Do this at a speed that is comfortable for you.

Do not stop until you have pushed the handle as far as possible. Stopping or hesitating in the middle of an injection may activate the needle guard and prevent proper administration of Lapelga®.

Do not lift the autoinjector during injection.

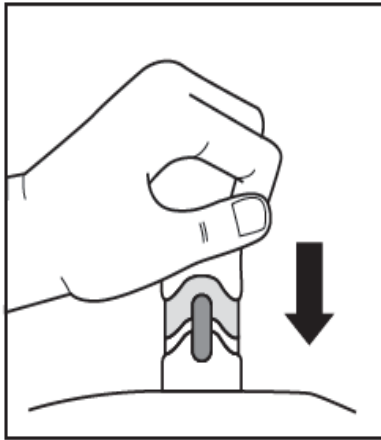

9. Injection is completed when the handle has been pushed down as far as possible, you hear a click and the orange body is no longer visible. It is recommended to hold the device in place for 5 seconds after completing the injection before lifting the device off the skin.

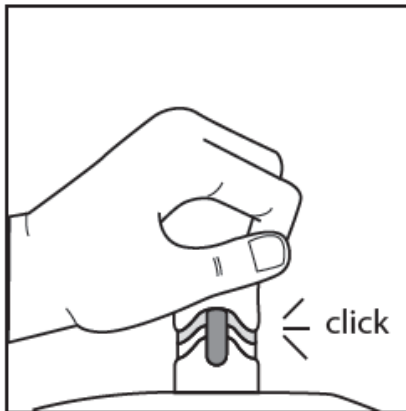

10. Lift straight up: The yellow band indicates that the needle guard is locked.

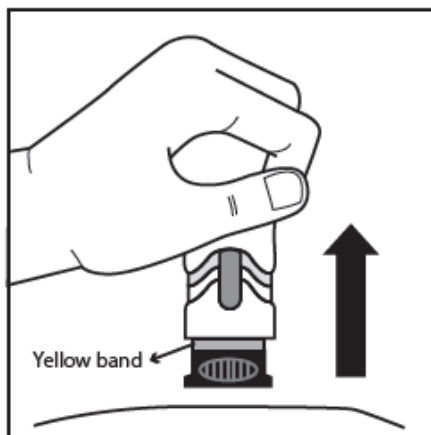

11. Place the used Lapelga® pre-filled autoinjector into a puncture-proof container for proper disposal as described below. Use each pre-filled autoinjector for only one injection.

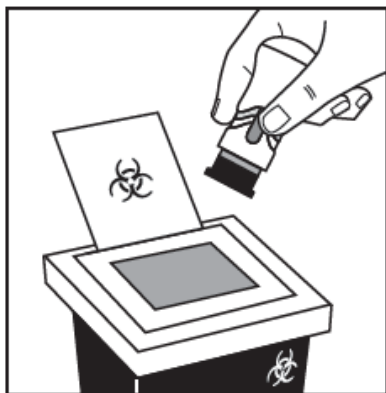

### Remember

Do not hesitate to consult your doctor or nurse for help or if you have any concerns.

### Disposal of Used Autoinjectors

The used autoinjectors should be disposed of in accordance with local requirements.

- Put used autoinjectors into an appropriate puncture-proof container as instructed by your doctor/nurse.
- **Always** keep this container **out of reach and sight of children**.
- When the puncture-proof container is full, it should be disposed as instructed by your doctor, nurse or pharmacist. **Do not throw the container in the household trash. Do not recycle.**
- Never put used autoinjectors into your normal household waste bin.

### What are possible side effects from using Lapelga®?

These are not all the possible side effects you may feel when taking Lapelga®. If you experience any side effects not listed here, contact your healthcare professional.

- **Spleen Rupture.** Your spleen may become enlarged and can rupture while taking Lapelga®. A ruptured spleen can cause death. The spleen is located in the upper left section of your stomach area. Call your doctor right away if you have pain in the left upper stomach area or left shoulder tip area. This pain could mean your spleen is enlarged or ruptured.
- **Serious Allergic Reactions.** Serious allergic reactions can also happen. These reactions may cause a rash over the whole body, shortness of breath, wheezing, a drop in blood pressure (usually causing dizziness or lightheadedness), swelling around the mouth or eyes, fast pulse, or sweating. If you experience an allergic reaction during the injection of Lapelga®, the injection should be stopped immediately. **If at any time a serious allergic reaction occurs, immediately call a doctor or emergency services (for example, call 911).**
- **A serious lung problem called acute respiratory distress syndrome (ARDS).** Call your doctor or seek emergency care right away if you have shortness of breath, trouble breathing or a fast rate of breathing.
- **Kidney injury (glomerulonephritis)** has been seen in patients who received pegfilgrastim. Call your doctor immediately if you experience puffiness in your face or ankles, blood in your urine or brown coloured urine, or if you notice that you urinate less often than usual.

**What are the most common side effects of Lapelga®?**

The most common side effect that you may experience is aching in the bones and muscles. If this occurs, it can usually be relieved with a non-acetylsalicylic acid over-the-counter pain reliever. Ask your doctor which is the most suitable one for you.

Some patients experience redness, swelling, or itching at the site of injection. This may be an allergy to the ingredients in Lapelga®, or it may be a local reaction. If you notice any of these signs or symptoms, call your doctor.

<b>Serious side effects and what to do about them</b>			
<b>Symptom / effect</b>	<b>Talk to your healthcare professional</b>		<b>Stop taking drug and get immediate medical help</b>
	<b>Only if severe</b>	<b>In all cases</b>	
<b>VERY COMMON ≥ 10%</b>			
Bone Pain		√	
<b>UNCOMMON ≥ 0.1% and &lt; 1%</b>			
Low platelet counts (thrombocytopenia) (including the following symptoms: easy bruising and increased bleeding).		√	
Allergic reactions (including the following symptoms: rash over the whole body, shortness of breath, a drop in blood pressure (usually causing dizziness or lightheadedness), swelling around the mouth or eyes, fast pulse, weakness, sweating; severe redness or swelling or itching at injection site).		√	√
Acute respiratory distress syndrome (including the following symptoms: fever, shortness of breath, cough, or congestion in your lungs).		√	√
<b>VERY RARE &lt; 0.01%</b>			
Splenomegaly (including the following symptoms: pain in the left upper stomach area or left shoulder tip area).		√	
<b>*FREQUENCY NOT KNOWN</b>			
Splenic rupture (including the following symptoms: left upper abdominal pain or pain at the tip of your shoulder).		√	
Cutaneous Vasculitis (including the following symptoms: A rash in the skin surface that looks		√	



like purple or red spots or bumps, clusters of small dots, splotches or hives. Your skin may also be itchy).			
Capillary Leak Syndrome (including the following symptoms: swelling or puffiness, which may be associated with passing water less frequently, difficulty breathing, abdominal swelling and feeling of fullness, and a general feeling of tiredness).		√	
Kidney Injury (glomerulonephritis) (including the following symptoms: puffiness in the face or ankles, blood in urine or brown coloured urine, or urinating less often than usual).		√	√
**Abnormal number of immature bone marrow cells (myelodysplastic syndrome) that could lead to a type of cancer (acute myeloid leukemia) (including the following symptoms: fever, bone pain, bruising, difficulty breathing, bleeding and a general feeling of tiredness).		√	√

\* Reported in the post-marketing setting where the incidence is not known.

\*\* Adverse events in breast and lung cancer patients receiving chemotherapy and/or radiotherapy.

If you have a troublesome symptom or side effect that is not listed here or becomes bad enough to interfere with your daily activities, talk to your healthcare professional.

<p><b>Reporting Side Effects</b></p> <p>You can report any suspected side effects associated with the use of health products to Health Canada by:</p> <ul style="list-style-type: none"> <li>• Visiting the Web page on Adverse Reaction Reporting (<a href="https://www.canada.ca/en/health-canada/services/drugs-health-products/medeffect-canada/adverse-reaction-reporting.html">https://www.canada.ca/en/health-canada/services/drugs-health-products/medeffect-canada/adverse-reaction-reporting.html</a>) for information on how to report online, by mail or by fax; or</li> <li>• Calling toll-free at 1-866-234-2345.</li> </ul> <p><i>NOTE: Contact your health professional if you need information about how to manage your side effects. The Canada Vigilance Program does not provide medical advice.</i></p>
--

**Storage:**

- Lapelga® should be stored in the refrigerator at 2° to 8°C (36° to 46°F). Freezing should be avoided. Avoid shaking Lapelga®.
- If accidentally frozen, allow Lapelga® to thaw in the refrigerator before injecting. However, if

- frozen a second time, DO NOT use it and contact your doctor or nurse for further instructions.
- Lapelga<sup>®</sup> can be removed from the refrigerator and left at room temperature (not above 25°C) for a single period of up to 15 days that ends within the labelled expiry date. Once Lapelga<sup>®</sup> has been out at room temperature it should not be put back into the refrigerator. Any Lapelga<sup>®</sup> autoinjectors that have been out of the refrigerator for longer than 15 days should not be used and should be disposed of in accordance with local requirements.
  - Lapelga<sup>®</sup> should be protected from light, so you should keep it in its carton until you are ready to use it. Avoid leaving Lapelga<sup>®</sup> in direct sunlight.

For any questions about storage, contact your doctor or nurse.

Keep out of reach and sight of children.

**If you want more information about Lapelga<sup>®</sup>:**

- Talk to your healthcare professional
- Find the full product monograph that is prepared for healthcare professionals and includes this Patient Medication Information by visiting the Health Canada website (<https://www.canada.ca/en/health-canada/services/drugs-health-products/drug-products/drug-product-database.html>). Find the Patient Medication Information on the manufacturer's website at: <http://www.apotex.ca/products>, or by contacting DISpedia, Apotex's Drug Information Service at: 1-800-667-4708.

This leaflet was prepared by Apotex Inc., Toronto, Ontario, M9L 1T9.

Last Revised: