

PRODUCT MONOGRAPH
INCLUDING PATIENT MEDICATION INFORMATION

PrVABYSMO®

faricimab injection

Single-use pre-filled syringes and single-use vials

6 mg/0.05 mL solution for intravitreal injection

Professed Standard

Ophthalmological / Anti-vascular endothelial growth factor and anti-angiopoietin-2 agent

Hoffmann-La Roche Limited
7070 Mississauga Road
Mississauga, Ontario, Canada
L5N 5M8
www.rochecanada.com

Date of Initial Authorization:
May 27, 2022

Date of Revision:
December 13, 2024

Submission Control Number: 286519

VABYSMO® is a registered trademark of F. Hoffmann-La Roche AG, used under license
©Copyright 2024, Hoffmann-La Roche Limited

RECENT MAJOR LABEL CHANGES

1 INDICATIONS	07/2024
4 DOSAGE AND ADMINISTRATION, 4.1 Dosing Considerations	9/2024
4 DOSAGE AND ADMINISTRATION, 4.2 Recommended Dose and Dosage Adjustment	07/2024
4 DOSAGE AND ADMINISTRATION, 4.4 Administration	9/2024
7 WARNINGS AND PRECAUTIONS	07/2024

TABLE OF CONTENTS

Sections or subsections that are not applicable at the time of authorization are not listed.

RECENT MAJOR LABEL CHANGES	2
PART I: HEALTH PROFESSIONAL INFORMATION	4
1 INDICATIONS	4
1.1 Pediatrics	4
1.2 Geriatrics	4
2 CONTRAINDICATIONS	4
4 DOSAGE AND ADMINISTRATION	4
4.1 Dosing Considerations	4
4.2 Recommended Dose and Dosage Adjustment	4
4.3 Reconstitution	5
4.4 Administration	5
4.5 Missed Dose	15
5 OVERDOSAGE	15
6 DOSAGE FORMS, STRENGTHS, COMPOSITION AND PACKAGING	15
7 WARNINGS AND PRECAUTIONS	16
7.1 Special Populations	18
7.1.1 Pregnant Women	18
7.1.2 Breast-feeding	18
7.1.3 Pediatrics	18
7.1.4 Geriatrics	18
8 ADVERSE REACTIONS	19
8.1 Adverse Reaction Overview	19

8.2	Clinical Trial Adverse Reactions	19
8.3	Less Common Clinical Trial Adverse Reactions.....	22
8.4	Abnormal Laboratory Findings: Hematologic, Clinical Chemistry and Other Quantitative Data	22
8.5	Post-Market Adverse Reactions	22
9	DRUG INTERACTIONS	22
9.2	Drug Interactions Overview.....	22
9.3	Drug-Behavioral Interactions.....	22
9.4	Drug-Drug Interactions	22
9.5	Drug-Food Interactions	22
9.6	Drug-Herb Interactions	23
9.7	Drug-Laboratory Test Interactions	23
10	CLINICAL PHARMACOLOGY	23
10.1	Mechanism of Action	23
10.2	Pharmacodynamics.....	23
10.3	Pharmacokinetics.....	23
11	STORAGE, STABILITY AND DISPOSAL	24
12	SPECIAL HANDLING INSTRUCTIONS.....	25
	PART II: SCIENTIFIC INFORMATION	26
13	PHARMACEUTICAL INFORMATION.....	26
14	CLINICAL TRIALS	26
14.1	Clinical Trials by Indication	26
14.4	Immunogenicity	37
15	MICROBIOLOGY	37
16	NON-CLINICAL TOXICOLOGY	37
	PATIENT MEDICATION INFORMATION.....	39

PART I: HEALTH PROFESSIONAL INFORMATION

1 INDICATIONS

VABYSMO (faricimab injection) is indicated for the treatment of:

- Neovascular (wet) age-related macular degeneration (AMD)
- Diabetic macular edema (DME)
- Macular edema secondary to retinal vein occlusion (RVO)

1.1 Pediatrics

Pediatrics (< 18 years of age): No data are available to Health Canada; therefore, Health Canada has not authorized an indication for pediatric use.

1.2 Geriatrics

Geriatrics (≥ 65 years of age): No dose adjustment is required in patients ≥ 65 years of age (see 4.2 **Recommended Dose and Dosage Adjustment, Special Populations** and 10.3 **Pharmacokinetics, Special Populations and Conditions**).

2 CONTRAINDICATIONS

- Patients with ocular or periocular infections.
- Patients with active intraocular inflammation.
- Patients who are hypersensitive to Vabysmo or to any ingredient in the formulation, including any non-medicinal ingredient, or component of the container. For a complete listing, see 6 **DOSAGE FORMS, STRENGTHS, COMPOSITION AND PACKAGING**

4 DOSAGE AND ADMINISTRATION

4.1 Dosing Considerations

- Single-use pre-filled syringe or single-use vial for intravitreal injection only.
- Vabysmo must be administered by a qualified physician experienced in intravitreal injections.
- Each pre-filled syringe or vial should only be used for the treatment of a single eye.

4.2 Recommended Dose and Dosage Adjustment

Neovascular (wet) Age-related Macular Degeneration (AMD)

The recommended dose for Vabysmo is 6 mg (0.05 mL) administered by intravitreal injection every 4 weeks (approximately every 28 ± 7 days) for the first 4 doses.

Thereafter, an assessment of disease activity based on visual acuity and/or anatomic parameters is recommended 20 and/or 24 weeks after treatment initiation and regularly thereafter. In patients without disease activity, treatment every 16 weeks could be considered. In patients with disease activity, treatment every 8 weeks or 12 weeks could be considered. If visual and/or anatomic outcomes change, the treatment interval should be adjusted accordingly. Treatment interval should be shortened

up to 8 weeks in a 4-week or 8-week reduction if visual and/or anatomic outcomes deteriorate (see 14 **CLINICAL TRIALS**).

Patients should be assessed regularly. Monitoring between the dosing visits should be scheduled based on the patient's status and at the physician's discretion.

Diabetic Macular Edema (DME)

Vabysmo is recommended to be administered by following one of these two dose regimens (see 14 **CLINICAL TRIALS**):

- 1) Vabysmo 6 mg (0.05 mL) administered by intravitreal injection every 4 weeks (approximately every 28 ± 7 days) for the first 6 doses, followed by 6 mg (0.05 mL) every 8 weeks;
- 2) Vabysmo 6 mg (0.05 mL) administered by intravitreal injection every 4 weeks (approximately every 28 ± 7 days) for at least 4 doses or until macular edema is resolved based on the central subfield thickness (CST) of the macula as measured by optical coherence tomography. Thereafter, the dosing interval may be modified using a treat-and-extend approach based on anatomic and visual acuity outcomes at dosing visits. In patients without disease activity, the dosing interval may be extended up to every 16 weeks (4 months) in up to 4-week increments. If anatomic and/or visual outcomes deteriorate, then the treatment interval should be shortened accordingly.

Patients should be assessed regularly. Monitoring between the dosing visits should be scheduled based on the patient's status and at the physician's discretion.

Macular edema secondary to retinal vein occlusion (RVO)

The recommended dose is 6 mg (0.05 mL) administered by intravitreal injection every 4 weeks (approximately every 28 ± 7 days) for 6 months.

Patients should be assessed regularly. Monitoring between the dosing visits should be scheduled based on the patient's status and at the physician's discretion.

Special Populations

Pediatrics (< 18 years of age)

Health Canada has not authorized an indication for pediatric use.

Geriatrics

No dose adjustment is required in patients ≥ 65 years of age (see 7.1.4 **Geriatrics** and 10.3 **Pharmacokinetics, Special Populations and Conditions**).

4.3 Reconstitution

Not applicable.

4.4 Administration

Vabysmo should be inspected visually for particulate matter and discoloration prior to administration (see 12 **SPECIAL HANDLING INSTRUCTIONS**).

The injection procedure must be carried out under aseptic conditions, which include the use of surgical hand disinfection, sterile gloves, a sterile drape and a sterile eyelid speculum (or equivalent). Sterile paracentesis equipment should be available as a precautionary measure. Adequate anesthesia and a

broad-spectrum topical microbicide to disinfect the periocular skin, eyelid and ocular surface should be administered prior to the injection.

Immediately following the intravitreal injection, patients should be monitored for elevation in intraocular pressure. Appropriate monitoring may consist of a check for perfusion of the optic nerve head or tonometry. If required, sterile equipment for paracentesis should be available.

Following intravitreal injection, patients should be instructed to report any symptoms suggestive of endophthalmitis (e.g. vision loss, eye pain, redness of the eye, photophobia, blurring of vision) without delay.

Pre-filled Syringe

Pre-filled Syringe**Before you start**

Read all the instructions carefully before using Vabysmo.

The Vabysmo carton includes:



A sterile pre-filled syringe in a sealed tray. The pre-filled syringe is for a single dose only.



A sterile, 30-gauge x ½ inch, ETW (Extra Thin Wall) injection filter needle with an integrated filter in the hub. The injection filter needle is for single use only.

Only use the provided injection filter needle for the administration, as it was designed to ensure safe ophthalmic use of the medicinal product.



Vabysmo should be refrigerated at temperatures between 2°C to 8°C.

Do not freeze.



Allow Vabysmo to reach room temperature (up to 25°C) before proceeding with the administration.



Prior to use, keep the sealed tray in the original carton to **protect the pre-filled syringe from light**. The pre-filled syringe may be kept at room temperature in the original carton for up to **24 hours**.



Vabysmo should be inspected visually prior to administration.

Do not use if the carton seals have been tampered with.

Do not use if the packaging, pre-filled syringe, injection filter needle is expired, damaged, or have been tampered with.

Do not use if the injection filter needle is missing.

Do not remove the finger grip from the syringe.

Do not use if the syringe cap is detached from the Luer lock.

Do not use if particulates, cloudiness, or discoloration are visible. Vabysmo is a clear to opalescent and colourless to brownish-yellow liquid solution.

Carton contents

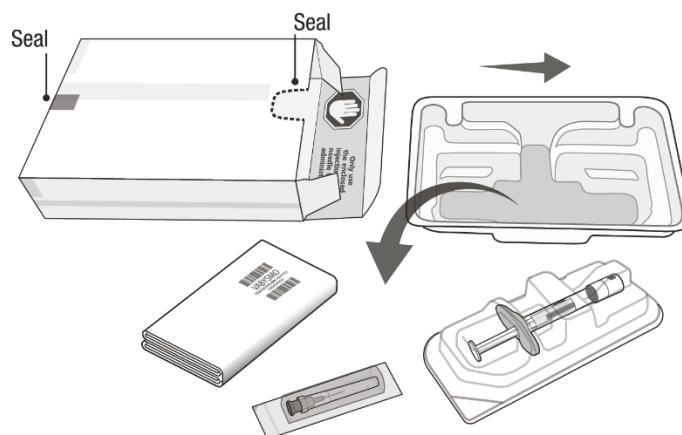

Figure A

Device description

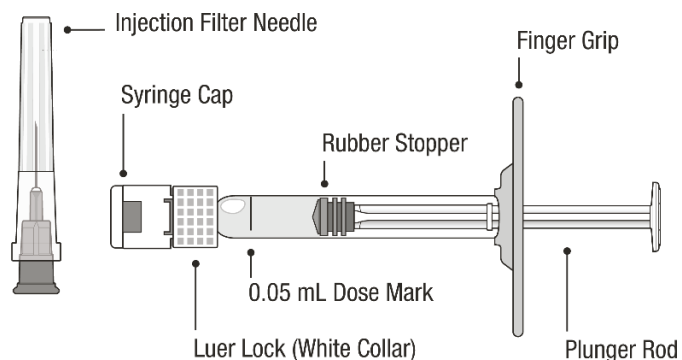

Figure B

Removal of the syringe from the syringe tray (step 1) and all subsequent steps should be done using aseptic technique.

Note: the dose must be set to the 0.05 mL dose mark.

Open tray and remove syringe cap

1. Peel the lid off the syringe tray and aseptically remove the pre-filled syringe.

2. Hold the syringe by the white collar; snap off the syringe cap (see **Figure C**).

Do not twist off the cap.

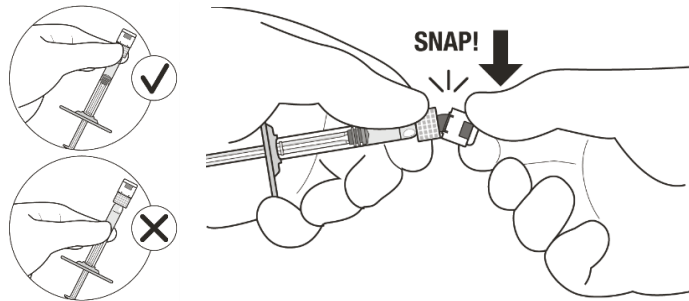

Figure C

Attach injection filter needle

3. Aseptically remove the injection filter needle from its packaging.
4. Aseptically and firmly attach the injection filter needle onto the syringe Luer lock (see **Figure D**).

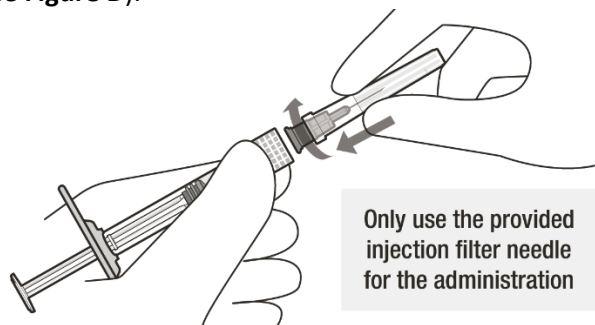

Figure D

5. Carefully remove the needle cap by pulling it straight off.

Dislodge air bubbles

6. Hold the syringe with the injection filter needle pointing up. Check the syringe for air bubbles.

7. If there are any air bubbles, gently tap the syringe with your finger until the bubbles rise to the top (see **Figure E**).

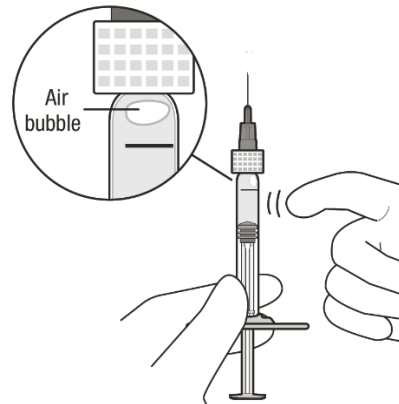

Figure E

Adjust medicinal product dose and expel air

8. Hold the syringe at eye level and **slowly** push the plunger rod until the **lower edge of the rubber stopper's dome** is aligned with the 0.05 mL dose mark (see **Figure F**). This will expel the air and the excess solution and set the dose to 0.05 mL.

Excess volume should be expelled prior to injection. The injection dose must be set to the 0.05 mL dose mark to avoid overdose.

Ensure that the injection is given **immediately** after preparation of the dose.

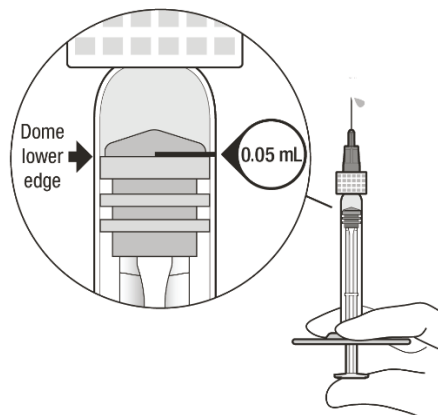

Figure F

Injection procedure

9. The injection procedure should be carried out under aseptic conditions. Inject **slowly** until rubber stopper reaches the bottom of the syringe to deliver the volume of 0.05 mL.
- Do not** recap or detach the injection filter needle from the syringe. Any unused medicinal product or waste material should be disposed of in accordance with local regulations.

Vial**Preparation for Administration****Vial****Before you start**

Read all the instructions carefully before using Vabysmo.



The Vabysmo kit includes a glass vial and transfer filter needle. The glass vial is for a single dose only. The filter needle is for single use only.



Vabysmo should be stored refrigerated at temperatures between 2°C to 8°C.

Do not freeze.

Do not shake.



Allow Vabysmo to reach room temperature (up to 25°C) before proceeding with the administration. Keep the vial in the original carton to **protect from light**.

The Vabysmo vial may be kept at room temperature for up to **24 hours**.



The Vabysmo vial should be inspected visually prior to administration. Vabysmo is a clear to opalescent and colourless to brownish-yellow liquid solution.

Do not use if particulates, cloudiness, or discolouration are visible.

Do not use if the packaging, vial and/or transfer filter needle are expired, damaged, or have been tampered with (see **Figure A**).

Use aseptic technique to carry out the preparation of the intravitreal injection.

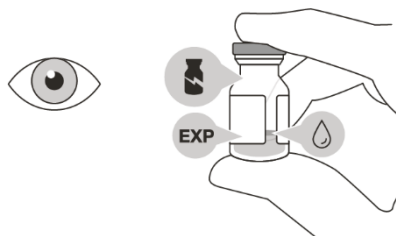

Figure A

Gather supplies**1.** Gather the following supplies:

- One Vabysmo vial (included)
- One sterile 5- μ m blunt transfer filter needle 18-gauge x 1½ inch (included)
- One sterile 1 mL Luer lock syringe with a 0.05 mL dose mark (**not included**)
- One sterile injection needle 30-gauge x ½ inch (**not included**)

Note that a 30-gauge injection needle is recommended to avoid increased injection forces that could be experienced with smaller diameter needles.

- Alcohol swab (**not included**).

- 2.** To ensure all liquid settles at the bottom of the vial, place the vial upright on a flat surface (for about 1 minute) after removal from packaging (see **Figure B**). Gently tap the vial with your finger (see **Figure C**), as liquid may stick to the top of the vial.

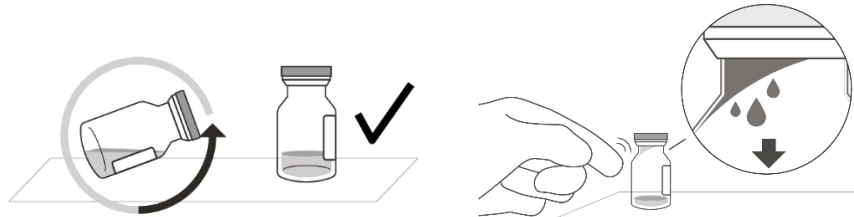

Figure B

Figure C

- 3.** Remove the flip-off cap from the vial (see **Figure D**) and wipe the vial septum with an alcohol swab (see **Figure E**).



Figure D

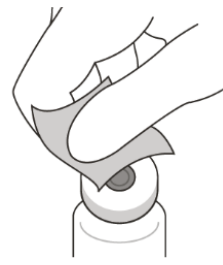

Figure E

Transfer drug product from vial to syringe

4. Aseptically and firmly attach the included 18-gauge x 1½ inch transfer filter needle onto a 1 mL Luer lock syringe (see **Figure F**).

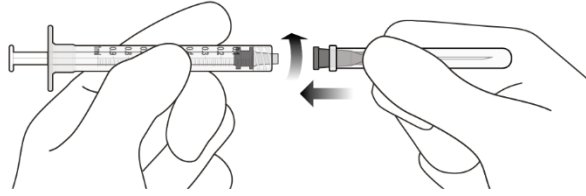

Figure F

5. Using aseptic technique, push the transfer filter needle into the center of the vial septum (see **Figure G**), push it all the way in, then tilt the vial slightly so that the needle touches the bottom edge of the vial (see **Figure H**).

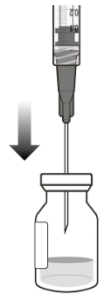

Figure G

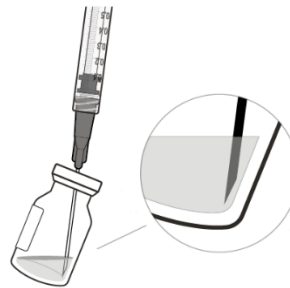

Figure H

6. Hold the vial slightly inclined and **slowly** withdraw all the liquid from the vial (see **Figure I**). Keep the bevel of the transfer filter needle submerged in the liquid, with the bevel facing down, to avoid introduction of air.

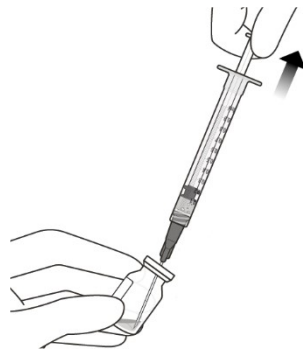

Figure I

Attach injection needle

7. Ensure that the plunger rod is drawn sufficiently back when emptying the vial, in order to completely empty the transfer filter needle (see **Figure I**).
8. Disconnect the transfer filter needle from the syringe and dispose of it in accordance with local regulations.

Do not use the transfer filter needle for the intravitreal injection.

9. Aseptically and firmly attach a 30-gauge x ½ inch injection needle onto the Luer lock syringe (see **Figure J**).

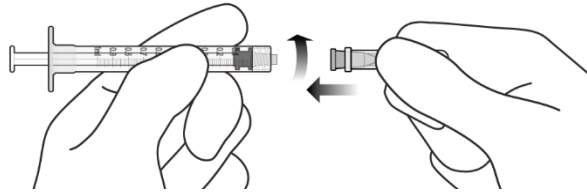

Figure J

Dislodge air bubbles and adjust drug dose

10. Carefully remove the plastic needle shield from the needle by pulling it straight off.
11. To check for air bubbles, hold the syringe with the needle pointing up. If there are any air bubbles, gently tap the syringe with your finger until the bubbles rise to the top (see **Figure K**).

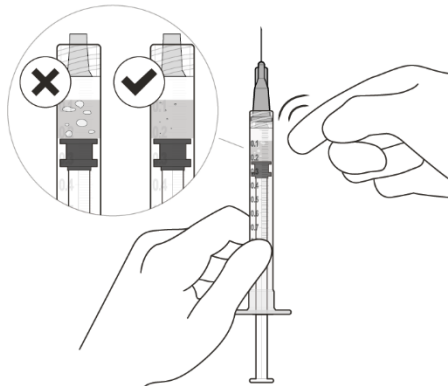

Figure K

12. Carefully expel the air from the syringe and needle, and **slowly** depress the plunger to align the rubber stopper tip to the 0.05 mL dose mark. The syringe is ready for the injection (see **Figure L**). Ensure that the injection is given **immediately** after preparation of the dose.

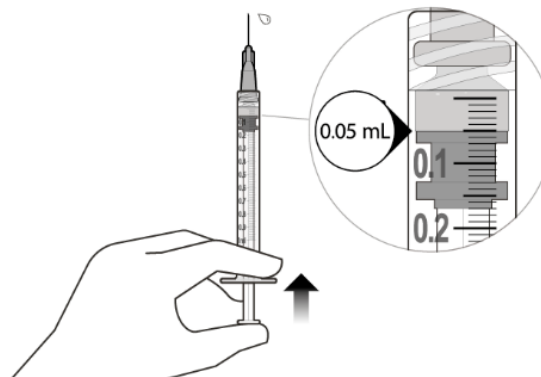

Figure L

Injection Procedure

Inject slowly until the rubber stopper reaches the end of the syringe to deliver the volume of 0.05 mL. Confirm delivery of the full dose by checking that the rubber stopper has reached the end of the syringe barrel.

Any waste material or unused medicinal product should be disposed of in accordance with local regulations.

4.5 Missed Dose

If a dose is delayed or missed, the patient should return to be assessed by physician as soon as possible and continue dosing depending on physician's discretion.

5 OVERDOSAGE

Doses higher than the recommended dosing regimen have not been studied. Overdosing with greater than recommended injection volume may increase intraocular pressure.

In the event of an overdose, intraocular pressure (IOP) should be monitored and, if deemed necessary by the treating physician, appropriate treatment should be initiated.

For management of a suspected drug overdose, contact your regional poison control centre.

6 DOSAGE FORMS, STRENGTHS, COMPOSITION AND PACKAGING

To help ensure the traceability of biologic products, including biosimilars, health professionals should recognise the importance of recording both the brand name and the non-proprietary (active ingredient) name as well as other product-specific identifiers such as the Drug Identification Number (DIN) and the batch/lot number of the product supplied.

Table 1 Dosage Forms, Strengths, Composition and Packaging

Route of Administration	Dosage Form / Strength/Composition	Non-medicinal Ingredients
Intravitreal Injection	Solution 6 mg/0.05 mL	Acetic acid 30% (for pH adjustment), D-sucrose, L-histidine, L-methionine, polysorbate 20, sodium chloride, water for injections

Vabysmo injection is a sterile, preservative-free, clear to opalescent, colourless to brownish-yellow solution, available in a single-use pre-filled syringe or single-use glass vial.

Pre-filled Syringe

Each pre-filled syringe contains 21 mg faricimab in 0.175 mL solution. This provides a usable amount to deliver a single dose of 0.05 mL solution containing 6 mg of faricimab.

Each carton contains one glass pre-filled syringe and one sterile Extra Thin Wall injection filter needle (30-gauge x ½ inch, 0.30 mm x 40 mm).

Vial

Each vial contains 28.8 mg faricimab in 0.24 mL solution. This provides a usable amount to deliver a single dose of 0.05 mL solution containing 6 mg of faricimab.

Each carton contains one glass vial and one sterile 5 µm blunt transfer filter needle (18-gauge x 1½ inch, 1.2 mm x 40 mm).

7 WARNINGS AND PRECAUTIONS**Driving and Operating Machinery**

Patients may experience temporary visual disturbances following the intravitreal injection with Vabysmo and the associated eye examination. Patients should not drive or use machines until visual function has recovered sufficiently.

Hypersensitivity

As with all therapeutic proteins, there is the potential for immune response to Vabysmo. Hypersensitivity reactions may manifest as rash, pruritus, urticaria, erythema, severe intraocular inflammation or anaphylactic reactions. Patients should be instructed to report any symptoms of anaphylaxis or intraocular inflammation such as vision loss, eye pain, increased sensitivity to light, floaters or worsening eye redness, which might be a clinical sign attributable to hypersensitivity.

Ophthalmologic***Endophthalmitis, Intraocular Inflammation, Retinal Detachments and Traumatic Cataract***

Intravitreal injections, including those with Vabysmo, have been associated with endophthalmitis, intraocular inflammation, rhegmatogenous retinal detachment, retinal tear and iatrogenic traumatic cataract (see 8 **ADVERSE REACTIONS**). Proper aseptic injection techniques must always be used when administering Vabysmo. Patients should be instructed to report any symptoms, such as eye pain, loss of vision, photophobia, blurred vision, floaters, or redness, suggestive of endophthalmitis or any of the above-mentioned events without delay, to permit prompt and appropriate management. Patients with increased frequency of injections may be at increased risk of procedural complications.

Retinal Vasculitis and Retinal Occlusive Vasculitis

Retinal vasculitis and retinal occlusive vasculitis have been reported with the use of Vabysmo, typically in the presence of intraocular inflammation or treatment with other intravitreal agents. Discontinue treatment with Vabysmo in patients who develop these events. Patients experiencing any change in vision following treatment should talk to their health care professional without delay.

Retinal Pigment Epithelial Tear

Retinal pigment epithelial tear has been reported with the use of Vabysmo (see 8 **ADVERSE REACTIONS**). Risk factors associated with the development of a retinal pigment epithelial tear after anti-VEGF therapy for wet AMD include a large and/or high pigment epithelial detachment. When initiating Vabysmo therapy, caution should be used in patients with these risk factors for retinal pigment epithelial tears.

Increases in Intraocular Pressure (IOP)

Transient increases in intraocular pressure (IOP) have been seen within 60 minutes of intravitreal injection, including those with Vabysmo. Sustained (present at 2 or more consecutive visits) IOP

increases > 21 mm Hg have also been reported. In all cases, both the IOP and perfusion of the optic nerve head and/or vision must be monitored and managed appropriately.

Special precaution is needed in patients with poorly controlled glaucoma. Do not inject Vabysmo while the IOP is ≥ 30 mmHg.

Bilateral Treatment

The safety and efficacy of Vabysmo administered in both eyes concurrently have not been studied.

Concomitant Use of Other Anti-VEGF

There are no data available on the concomitant use of Vabysmo with anti-VEGF medicinal products or other therapies (e.g., photodynamic therapy) in the same eye.

Withholding Treatment

Treatment should be withheld in patients with:

- Rhegmatogenous retinal detachment, stage 3 or 4 macular holes, retinal break; treatment should not be resumed until an adequate repair has been performed.
- Treatment related decrease in Best Corrected Visual Acuity (BCVA) of ≥ 30 letters compared with the last assessment of visual acuity; treatment should not be resumed earlier than the next scheduled treatment.
- Performed or planned intraocular surgery within the previous or next 28 days; treatment should not be resumed earlier than the next scheduled treatment.

Populations with Limited Data

In wet AMD clinical trials, there is limited data in patients with the total lesion size > 9 disc areas on fundus fluorescein angiography. There is only limited experience in the treatment of DME patients with HbA1c over 10%, patients with high-risk proliferative diabetic retinopathy (DR), or wet AMD, DME and RVO patients with active systemic infections. There is also no experience of treatment with Vabysmo in diabetic and RVO patients with uncontrolled hypertension. This lack of information should be considered by the physician when treating such patients.

Reproductive Health: Female and Male Potential

- **Contraception**

Women of childbearing potential have to use effective contraception during treatment with Vabysmo and for at least 3 months following the last dose of Vabysmo (see 7.1.1 **Pregnant Women**).

- **Fertility**

No reproductive or fertility studies have been conducted to assess Vabysmo's impact on fertility.

No effects on reproductive organs in male or female animals were observed in a 6-month cynomolgus monkey study at Vabysmo doses of up to 3 mg/eye (8-10 times the clinical exposure based on AUC). VEGF inhibition has been shown to affect follicular development, corpus luteum function and fertility. Based on the mechanism of action of VEGF and Ang-2 inhibitors, there is a potential risk to female reproductive capacity (see 16 **NON-CLINICAL TOXICOLOGY, Reproductive and Developmental Toxicology**).

Systemic Effects

Arterial Thromboembolic Events (ATEs) and Non-ocular Hemorrhage

Systemic adverse events including arterial thromboembolic events and non-ocular hemorrhage have been reported following intravitreal injection of VEGF inhibitors, including Vabysmo (see 8 **ADVERSE REACTIONS**) and there is a theoretical risk that these may be related to VEGF inhibition. ATEs are defined as nonfatal stroke, nonfatal myocardial infarction, vascular death or death of unknown cause.

There are limited/no data on safety of faricimab in patients with history of stroke or transient ischemic attack or myocardial infarction.

7.1 Special Populations

7.1.1 Pregnant Women

There are no data from the use of Vabysmo in pregnant women.

In an embryofetal development study in pregnant cynomolgus monkeys, faricimab given intravenously throughout the period of organogenesis did not adversely affect pregnancy or fetal development at doses up to 3 mg/kg IV (523 times the clinical exposure based on the C_{max} at the maximum recommended human dose of a single 6 mg/eye intravitreal dose) (see 16 **NON-CLINICAL TOXICOLOGY, Reproductive and Developmental Toxicology**).

It is not known whether faricimab can cross the placenta or cause harm to the fetus when administered to pregnant women. The systemic exposure to faricimab is low after ocular administration, but due to its mechanism of action of VEGF and Ang-2 inhibitors, faricimab must be regarded as potentially teratogenic and embryo/fetotoxic. Therefore, Vabysmo should not be used during pregnancy unless the potential benefit to the patient outweighs the potential risk to the fetus.

7.1.2 Breast-feeding

No studies have been conducted to assess Vabysmo's impact on milk production, its presence in breast milk, or its effects on the nursing child.

It is not known whether faricimab is excreted in human breast milk. Precaution should be exercised because many drugs can be excreted in human milk. A risk to the breastfed child cannot be excluded. Breastfeeding is not recommended during treatment with Vabysmo and for at least one month after the last dose of Vabysmo. A decision must be made whether to discontinue breast-feeding or to postpone, if feasible, therapy with Vabysmo. The benefits of therapy should be weighed against potential adverse effects on the breast-fed child from Vabysmo.

7.1.3 Pediatrics

Pediatrics (< 18 years of age): No data are available to Health Canada; therefore, Health Canada has not authorized an indication for pediatric use.

7.1.4 Geriatrics

Geriatrics (≥ 65 years of age): In the Phase III wet AMD, DME and RVO clinical studies, approximately 58% (1,496/2,571) of patients randomized to treatment with Vabysmo were ≥ 65 years of age. No significant differences in efficacy or safety of Vabysmo were seen with increasing age in these studies (see 4.2 **Recommended Dose and Dosage Adjustment, Special Populations** and 10.3 **Pharmacokinetics, Special Populations and Conditions**).

8 ADVERSE REACTIONS

8.1 Adverse Reaction Overview

A total of 4,489 patients constituted the safety population in the six Phase III clinical studies for two years (2,567 Vabysmo treated patients; 664 in wet AMD, 1,262 in DME and 641 in RVO).

Treatment of wet AMD

The most frequently reported serious adverse reactions in patients treated with Vabysmo were retinal pigment epithelial (RPE) tear (0.6%), cataract (0.5%), endophthalmitis (0.5%), uveitis (0.5%), and visual acuity reduced (0.3%).

The most frequently reported adverse reactions in patients treated with Vabysmo were cataract (9%), conjunctival hemorrhage (9%), vitreous detachment (5%), vitreous floaters (5%), intraocular pressure (IOP) increased (4%), eye pain (4%) and RPE tear (3%).

The adverse reactions (regardless of causality) leading to permanent discontinuation of Vabysmo were uveitis, endophthalmitis, iridocyclitis, vitritis, and RPE tear.

Treatment of DME

The most frequently reported serious adverse reactions in patients treated with Vabysmo were cataract (1%), endophthalmitis (0.5%), uveitis (0.2%), retinal tear (0.2%) and vitreous hemorrhage (0.2%).

The most frequently reported adverse reactions in patients treated with Vabysmo were cataract (15%), conjunctival hemorrhage (8%), vitreous detachment (5%), vitreous floaters (4%), IOP increased (4%) and eye pain (3%).

The most frequently reported adverse reactions (regardless of causality) leading to permanent discontinuation of Vabysmo was uveitis.

Treatment of RVO

The most frequently reported serious adverse reaction in patients treated with Vabysmo was uveitis (0.5%).

The most frequently reported adverse reactions in patients treated with Vabysmo were conjunctival hemorrhage (3%), vitreous detachment (2%), vitreous floaters (2%), and IOP increased (1%).

The most frequently reported adverse reaction (regardless of causality) leading to permanent discontinuation of Vabysmo was uveitis.

8.2 Clinical Trial Adverse Reactions

Clinical trials are conducted under very specific conditions. The adverse reaction rates observed in the clinical trials; therefore, may not reflect the rates observed in practice and should not be compared to the rates in the clinical trials of another drug. Adverse reaction information from clinical trials may be useful in identifying and approximating rates of adverse drug reactions in real-world use.

Neovascular (Wet) Age-related Macular Degeneration (AMD)

The data described below reflect exposure to Vabysmo in 664 patients with wet AMD treated with the 6 mg dose in the two randomized, double-masked, active comparator (aflibercept 2 mg every 8 weeks) controlled clinical studies (TENAYA and LUCERNE) through Week 112 (see 14 **CLINICAL TRIALS**).

Table 2 Adverse Reactions ($\geq 1\%$) in the TENAYA and LUCERNE wet AMD Studies through Week 112

Adverse Reactions SOC Preferred Term MedDRA version 24.0	Week 60		Week 112	
	Vabysmo n = 664	Aflibercept n = 662	Vabysmo n = 664	Aflibercept n = 662
Eye disorders				
Conjunctival hemorrhage	8%	8%	9%	9%
Cataract	5%	3%	9%	8%
Vitreous detachment	4%	3%	5%	5%
Vitreous floaters	3%	2%	5%	3%
Intraocular pressure increased	3%	3%	4%	4%
Eye pain	3%	3%	4%	4%
Intraocular inflammation ^a	2%	< 1%	3%	1%
Retinal pigment epithelial tear	3%	2%	3%	2%
Eye irritation	1%	< 1%	2%	1%
Corneal abrasion	1%	1%	2%	2%
Eye pruritus	1%	< 1%	1%	< 1%
Ocular discomfort	1%	< 1%	1%	< 1%
Ocular hyperaemia	1%	1%	1%	< 1%
Vision blurred	< 1%	< 1%	1%	< 1%

^aIncluding iridocyclitis, iritis, uveitis and vitritis

Diabetic Macular Edema (DME)

The data described below reflect exposure to Vabysmo in 1,262 patients with DME treated with the 6 mg dose in the two randomized, double-masked, active comparator (aflibercept 2 mg every 8 weeks) controlled clinical studies (YOSEMITE and RHINE) through Week 100 (see 14 **CLINICAL TRIALS**).

Table 3 Adverse Reactions ($\geq 1\%$) in the YOSEMITE and RHINE DME Studies through Week 100

Adverse Reactions SOC Preferred Term MedDRA version 23.1	Baseline to Week 56		Baseline to Week 100	
	Vabysmo n = 1,262	Aflibercept n = 625	Vabysmo n = 1,262	Aflibercept n = 625
Eye disorders				
Cataract	5%	5%	15%	12%

Adverse Reactions SOC Preferred Term MedDRA version 23.1	Baseline to Week 56		Baseline to Week 100	
	Vabysmo n = 1,262	Aflibercept n = 625	Vabysmo n = 1,262	Aflibercept n = 625
Conjunctival hemorrhage	7%	6%	8%	7%
Vitreous detachment	3%	3%	5%	4%
Vitreous floaters	3%	2%	4%	3%
Intraocular pressure increased	3%	2%	4%	3%
Eye pain	2%	3%	3%	3%
Intraocular inflammation ^a	1%	< 1%	1%	< 1%
Lacrimation increased	< 1%	< 1%	1%	< 1%
Vitreous hemorrhage	1%	< 1%	< 1%	< 1%

^aIncluding iridocyclitis, iritis, uveitis and vitritis

Macular Edema Secondary to Retinal Vein Occlusion (RVO)

The data described below reflect exposure to Vabysmo in 641 patients with RVO treated with the 6 mg dose in the two randomized, double-masked, active comparator (aflibercept 2 mg every 4 weeks) controlled clinical studies (BALATON and COMINO) through week 24 (see 14 **CLINICAL TRIALS**).

Table 4 Adverse Reactions (≥ 1%) in the BALATON and COMINO RVO Studies through Week 24

Adverse Reactions SOC Preferred Term MedDRA version 25.0	Baseline to Week 24	
	Vabysmo n = 641	Aflibercept n = 635
Eye disorders		
Conjunctival hemorrhage	3%	4%
Vitreous detachment	2%	2%
Vitreous floaters	2%	2%
Intraocular inflammation ^a	1%	< 1%
Investigations		
Intraocular pressure increased	1%	3%

^aIncluding iridocyclitis, iritis, uveitis and vitritis

Description of Selected Adverse Reactions from Clinical Trials

Arterial Thromboembolic Events (ATEs)

The incidence of reported ATEs in the wet AMD studies from baseline to Week 112 was 3% (22 out of 664) in patients treated with Vabysmo compared with 3% (20 out of 662) in patients treated with aflibercept.

The incidence of reported ATEs in the DME studies from baseline to Week 100 was 5% (64 out of 1,262) in patients treated with Vabysmo compared with 5% (32 out of 625) in patients treated with aflibercept.

The incidence of reported ATEs in the RVO studies during the first 6 months was 1.1% (7 out of 641) in patients treated with Vabysmo compared with 1.4% (9 out of 635) in patients treated with aflibercept.

8.3 Less Common Clinical Trial Adverse Reactions

Less common adverse reactions reported in < 1% of the patients treated with Vabysmo in all Phase III studies [pooled data for Phase 3 studies for wet AMD (Week 112), DME (Week 100)] and RVO are listed below.

Eye Disorders: blurred vision, conjunctival hyperaemia, eye irritation, eye pruritus, iridocyclitis, iritis, lacrimation increased, ocular discomfort, ocular hyperemia, retinal tear, rhegmatogenous retinal detachment, sensation of foreign body, uveitis, vitritis, visual acuity reduced, visual acuity reduced transiently, and vitreous hemorrhage.

Infections and infestations: endophthalmitis

Injury, poisoning and procedural complications: cataract traumatic, corneal abrasion, procedural pain

8.4 Abnormal Laboratory Findings: Hematologic, Clinical Chemistry and Other Quantitative Data

Clinical Trial Findings

There were no findings to suggest a relationship between Vabysmo and the development of clinically significant laboratory abnormalities in the Phase III (TENAYA, LUCERNE, YOSEMITE, and RHINE) studies.

8.5 Post-Market Adverse Reactions

Rare cases of retinal vasculitis and/or retinal occlusive vasculitis have been spontaneously reported in the post-marketing setting. Retinal vasculitis and retinal occlusive vasculitis have also been reported in patients treated with IVT therapies.

Eye disorders: retinal vasculitis, retinal occlusive vasculitis

9 DRUG INTERACTIONS

9.2 Drug Interactions Overview

No drug interaction studies have been performed with Vabysmo.

9.3 Drug-Behavioral Interactions

No drug-behavioral studies have been performed with Vabysmo.

9.4 Drug-Drug Interactions

No drug-drug interaction studies have been performed with Vabysmo.

9.5 Drug-Food Interactions

No drug-food studies have been performed with Vabysmo.

9.6 Drug-Herb Interactions

No drug-herb studies have been performed with Vabysmo.

9.7 Drug-Laboratory Test Interactions

No drug-laboratory studies have been performed with Vabysmo.

10 CLINICAL PHARMACOLOGY

10.1 Mechanism of Action

Faricimab is a humanized bispecific immunoglobulin G1 (IgG1) antibody that acts through inhibition of both Ang-2 and vascular endothelial growth factor A (VEGF-A). By inhibiting VEGF-A, faricimab suppresses endothelial cell proliferation, neovascularization and vascular permeability. By inhibiting Ang-2, faricimab is thought to increase vascular stability and desensitize blood vessels to the effects of VEGF-A. Ang-2 levels are increased in some patients with wet AMD, DME and RVO.

10.2 Pharmacodynamics

Following intravitreal administration of faricimab in wet AMD, DME and RVO patients, free Ang-2 and VEGF-A in aqueous humor was reduced.

Reductions in mean central subfield thickness (CST) from baseline were observed in patients with wet AMD, DME or RVO treated with Vabysmo in the six clinical trials (TENAYA, LUCERNE, RHINE, YOSEMITE, BALATON and COMINO).

In wet AMD patients, the mean CST change from baseline to the primary endpoint visits (averaged at Weeks 40, 44 and 48) for Vabysmo versus aflibercept (Q8W) was -137 μm vs. -129 μm (TENAYA) and -137 μm vs. -131 μm (LUCERNE); and -146.5 μm vs. -146.2 μm (TENAYA) and -150.3 μm vs. -141.6 μm (LUCERNE) averaged at Weeks 104, 108 and 112.

In DME patients treated with Vabysmo Q8W or Vabysmo variable dosing versus aflibercept Q8W, the mean change in CST from baseline was -207 μm and -197 μm vs. -170 μm (YOSEMITE) and -196 μm , -188 μm vs. -170 μm (RHINE) at the primary endpoint visits (averaged at Weeks 48, 52 and 56); and -216 μm , -205 μm vs. -196 μm (YOSEMITE) and -203 μm , -197 μm vs. -186 μm (RHINE) averaged at Weeks 92, 96 and 100.

In patients with branch retinal vein occlusion (BRVO; BALATON) and central/hemiretinal vein occlusion (C/HRVO; COMINO) treated with Vabysmo every 4 weeks (Q4W), the mean CST reduction from baseline to week 24 was 311.4 μm for Vabysmo versus 304.4 μm for aflibercept, and 461.6 μm for Vabysmo Q4W versus 448.8 μm for aflibercept Q4W, in BALATON and COMINO, respectively.

10.3 Pharmacokinetics

Absorption and Distribution

Based on a population pharmacokinetic analysis (including wet AMD and DME, N=2,246), maximum free (unbound to VEGF-A and Ang-2) faricimab plasma concentrations (C_{max}) are estimated to occur approximately 2 days post-dose. Mean (\pm SD) plasma C_{max} are estimated 0.23 (0.07) mcg/mL and 0.22 (0.07) mcg/mL respectively in wet AMD and DME patients. After repeated administrations, mean plasma free faricimab trough concentrations are predicted to be 0.002-0.003 mcg/mL for Q8W dosing.

No accumulation of faricimab was apparent in the vitreous or in plasma following repeated intravitreal

dosing. No apparent suppression of Ang-2 or VEGF-A was observed in plasma.

Pharmacokinetic analysis of patients with wet AMD, DME, and RVO (N = 2,977) has shown that the pharmacokinetics of faricimab are comparable in wet AMD, DME, and RVO patients.

Metabolism and Elimination

The metabolism of faricimab has not been directly studied. As a monoclonal antibody, faricimab is expected to be metabolized principally by catabolism through IgG proteolysis.

The estimated mean vitreous elimination half-life of faricimab is approximately 7.5 days.

Special Populations and Conditions

- No clinically meaningful differences in faricimab pharmacokinetics were observed based on age, gender, and race.
- **Hepatic Insufficiency:** No formal pharmacokinetic study has been conducted in patients with hepatic impairment.
- **Renal Insufficiency:** No formal pharmacokinetic study has been conducted in patients with renal impairment. Population pharmacokinetic analysis of pooled data from all clinical studies of which 63% had renal impairment (mild 38%, moderate 23%, and severe 2%), revealed no differences with respect to systemic pharmacokinetics of faricimab after intravitreal administration of Vabysmo.

11 STORAGE, STABILITY AND DISPOSAL

Store in a refrigerator (2°C to 8°C).

Do not freeze.

Keep the sealed tray containing the pre-filled syringe or vial in the original carton to protect from light.

Prior to use, the sealed tray containing the pre-filled syringe or unopened vial may be kept at room temperature (up to 25°C), in the original carton, for up to 24 hours.

Ensure that the injection is given immediately after preparation of the dose.

Vabysmo should not be used after the expiry date (EXP) shown on the pack.

Keep out of reach and sight of children.

Incompatibilities

In the absence of compatibility studies, this medicinal product must not be mixed with other medicinal products.

Disposal of Unused/Expired Medicines

The release of pharmaceuticals in the environment should be minimized. Medicines should not be disposed of via wastewater and disposal through household waste should be avoided.

The following points should be strictly adhered to regarding the use and disposal of syringes and other medicinal sharps:

- Needles and syringes should never be reused.
- Place all used needles and syringes into a sharps container (puncture-proof disposable container).

Any unused medicinal product or waste material should be disposed of in accordance with local requirements.

12 SPECIAL HANDLING INSTRUCTIONS

Do not shake.

Vabysmo should be inspected visually upon removal from the refrigerator and prior to administration. Do not use if particulates, cloudiness, or discolouration are visible. Do not use if the packaging, pre-filled syringe, injection filter needle, vial or transfer filter needle are damaged or expired.

The contents of the pre-filled syringe and vial are sterile and for single use only.

Use aseptic technique for preparation of the intravitreal injection.

PART II: SCIENTIFIC INFORMATION**13 PHARMACEUTICAL INFORMATION****Drug Substance**

Proper Name:	faricimab
Chemical name:	humanized bispecific antibody of the CrossMAb format that selectively binds vascular endothelial growth factor A (VEGF) and angiopoetin 2 (Ang 2)
Molecular formula and molecular mass:	C ₆₅₀₆ H ₉₉₆₂ N ₁₇₂₄ O ₂₀₄₁ S ₄₅ Approximately 146 kDa (peptide chains only, heavy chains without C terminal lysine residues)
Structural formula:	The recombinant bispecific antibody is produced in CHO cells and consists of two different heavy chains (VEGF HC: HC1 with 452 amino acid residues, Ang-2 HC: HC2 with 462 amino acid residues; without C-terminal lysine) and two different light chains (VEGF LC: LC1 with 214 amino acid residues, Ang-2-LC: LC2 with 213 amino acid residues) with inter and intra chain disulfide bonds that are typical for IgG1 antibodies plus an additional disulfide bridge in the C _H 3 C _H 3 interface
Physicochemical properties:	Faricimab is a sterile, preservative-free, clear to opalescent, colourless to brownish-yellow solution. The pH of the solution of faricimab is in the range of 5.3 – 5.8.
Pharmaceutical standard:	Professed

Product Characteristics:

Faricimab is a humanized bispecific antibody produced in mammalian Chinese Hamster Ovary (CHO) cell culture by recombinant DNA technology.

14 CLINICAL TRIALS**14.1 Clinical Trials by Indication****Treatment of wet AMD**

The safety and efficacy of Vabysmo (faricimab) were assessed in two randomized, multi-center, double-masked, active comparator-controlled studies in patients with wet AMD, Study GR40306 (TENAYA) and Study GR40844 (LUCERNE). A total of 1,329 patients were enrolled in these studies, with 1,135 (85%) patients completing the studies through Week 112. A total of 1,326 patients received at least one dose (664 with Vabysmo).

Table 5 Summary of patient demographics for clinical trials in wet AMD

Study #	Study design	Dosage, route of administration and duration	Study subjects (n)	Mean age (Range)	Sex
GR40306 (TENAYA)	Randomized, multi-center, double-masked, active comparator-controlled studies	Vabysmo (see below for details) Aflibercept 2mg Q8W after three initial monthly doses	Vabysmo: N=334	76.3 (50-99 years)	Male: 40.1 % Female: 59.9%
GR40844 (LUCERNE)			Aflibercept: N=337		
			Vabysmo: N=331	75.5 (50-99 years)	Male: 40.6 % Female: 59.4 %
			Aflibercept: N=327		

In both studies, patients were randomized in a 1:1 ratio to one of two treatment arms:

- Aflibercept 2 mg every 8 weeks (Q8W) after three initial monthly doses. Patients in the aflibercept arm remained on Q8W dosing throughout the study period.
- Vabysmo: After the first 6 mg four monthly doses (Weeks 0, 4, 8, and 12), patients received 6 mg every 16 weeks (Q16W), every 12 weeks (Q12W) or every 8 weeks (Q8W) dosing based on assessments of pre-specified visual and anatomic criteria at Weeks 20 and 24 as well as treating physician clinical assessment. Patients remained on these fixed dosing intervals until Week 60 without supplemental therapy. From Week 60 onwards, patients in the Vabysmo arm moved to an adjustable dosing regimen, where the dosing interval could be increased in up to 4-week increments (up to Q16W) or could be decreased by up to 8-week increments (up to Q8W) based on an objective assessment of pre-specified visual and anatomic disease activity criteria at study drug dosing visits.
- Both studies were 112 weeks in duration.

The primary efficacy endpoint was the mean change in BCVA from baseline based on an average at Weeks 40, 44 and 48 (i.e., Year 1), as measured by the Early Treatment Diabetic Retinopathy Study (ETDRS) letter score. The secondary endpoints included proportion of patients gaining ≥ 15 letters in BCVA from baseline based on an average at Weeks 40, 44 and 48.

In both studies (TENAYA and LUCERNE), non-inferiority of Vabysmo compared to aflibercept Q8W was demonstrated using mean change in BCVA from baseline at Year 1. The results are summarized in **Table 6** and in **Figure 1** and **Figure 2** below.

Table 6 Efficacy outcomes at Year 1^a in TENAYA and LUCERNE

Efficacy Outcomes	TENAYA		LUCERNE	
	Vabysmo N = 334	Aflibercept Q8W N = 337	Vabysmo N = 331	Aflibercept Q8W N = 327
Mean BCVA (SD) at baseline	61.3 (12.5)	61.5 (12.9)	58.7 (14.0)	58.9 (13.3)
Mean change in BCVA from baseline as measured by ETDRS letter score (95% CI)	5.8 (4.6, 7.1)	5.1 (3.9, 6.4)	6.6 (5.3, 7.8)	6.6 (5.3, 7.8)
Difference in LS mean (95% CI)	0.7 (-1.1, 2.5) ^b		0.0 (-1.7, 1.8) ^b	
Proportion of patients with ≥ 15 letter gain from baseline ^c	20.0% (15.6%, 24.4%)	15.7% (11.9%, 19.6%)	20.2% (15.9%, 24.6%)	22.2% (17.7%, 26.8%)
Difference (95% CI)	4.3% (-1.6%, 10.1%)		-2.0% (-8.3%, 4.3%)	

^aAverage of Weeks 40, 44 and 48^bMet the pre-specified non-inferiority margin of 4 letters for the primary endpoint in both studies^cCochran-Mantel-Haenszel weighted proportion

BCVA: Best Corrected Visual Acuity

ETDRS: Early Treatment Diabetic Retinopathy Study

CI: Confidence Interval

LS: Least Square

SD: Standard Deviation

Figure 1 Mean change in BCVA from baseline to Week 112 in TENAYA

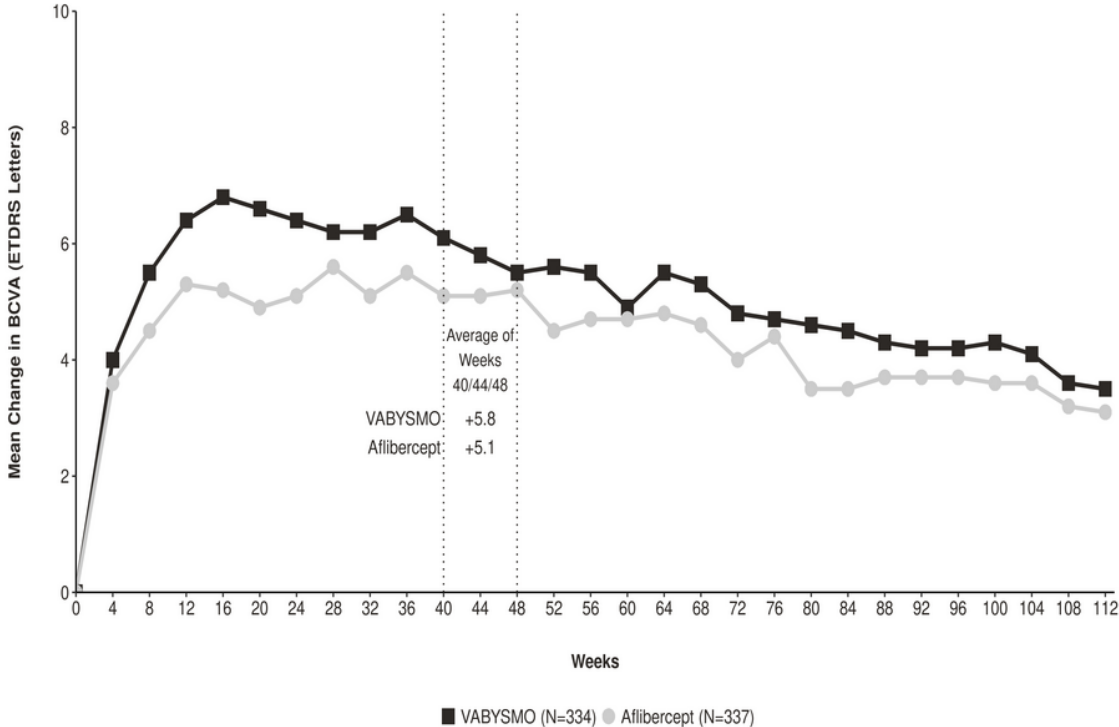
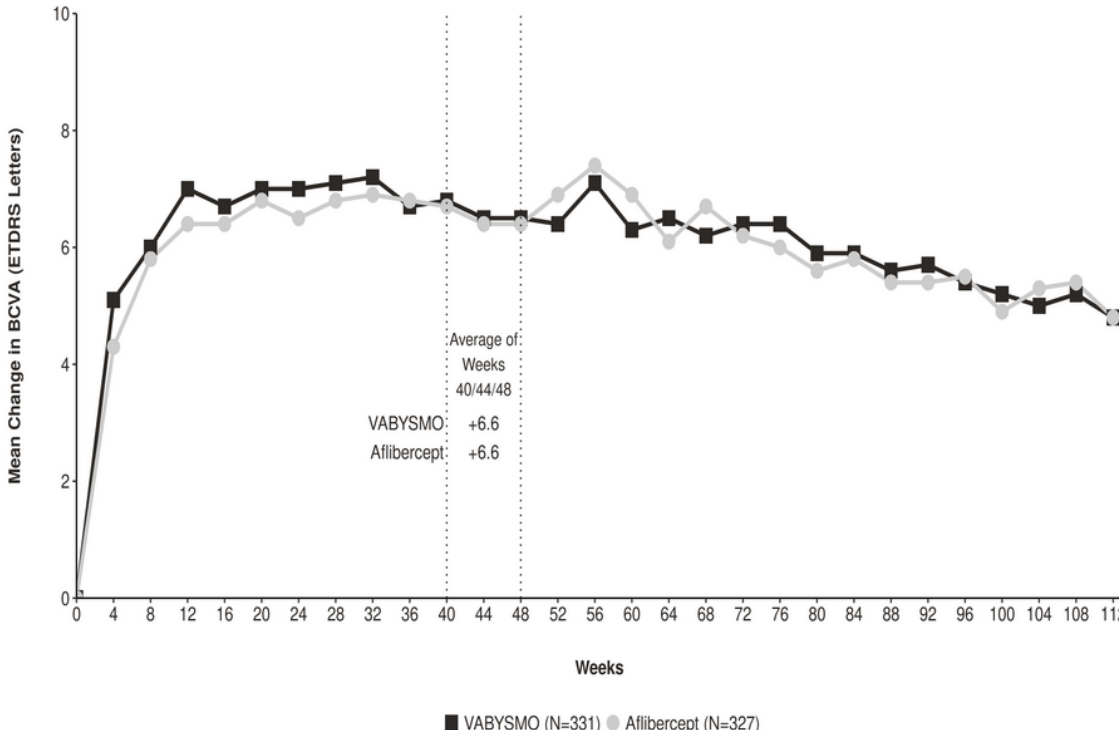

Figure 2 Mean change in BCVA from baseline to Week 112 in LUCERNE



The proportion of patients on each of the faricimab treatment intervals at Week 48 in TENAYA and LUCERNE, respectively was: Q16W: 46%, 45%; Q12W: 34%, 33%; Q8W: 20%, 22%. The proportion of patients on each of the faricimab treatment intervals at Week 112 in TENAYA and LUCERNE, respectively was: Q16W: 59%, 67%; Q12W: 15%, 14%; Q8W: 26%, 19%.

The mean change in BCVA from baseline in TENAYA and LUCERNE at Weeks 104, 108 and 112 (averaged across visits) was 3.7 and 5.0 letters for Vabysmo and 3.3 and 5.2 letters for aflibercept, respectively. The proportions of patients who gained at least 15 letters in BCVA from baseline at Week 112 in TENAYA and LUCERNE were 23% and 22% for patients receiving Vabysmo and 17% and 21% for patients receiving aflibercept Q8W, respectively.

Treatment of DME

The safety and efficacy of Vabysmo were assessed in two randomized, multi-centre, double-masked, active comparator-controlled 2-year studies (YOSEMITE and RHINE) in patients with DME. A total of 1,891 patients were enrolled in the two studies with 1622 (85.8%) patients completing the studies through Week 100. A total of 1,887 patients were treated with at least one dose through Week 56 (1,262 with Vabysmo). The overall population included both anti-VEGF naive patients (78%) and patients who had been previously treated with a VEGF inhibitor prior to study participation (22%).

Table 7 Summary of patient demographics for clinical trials in DME

Study #	Study design	Dosage, route of administration and duration	Study subjects (n)	Mean age (Range)	Sex
GR40349 (YOSEMITE)	Randomized, multi-center, double-masked, active comparator-controlled studies	Vabysmo administered every 8 weeks (Q8W) after the first 6 monthly doses.	Vabysmo (Q8W): N=315 Vabysmo variable dosing N=313 Aflibercept: N=312	62.2 (24-85 years)	Male: 59.8% Female: 40.2 %
GR40398 (RHINE)		Vabysmo variable dosing administered in variable intervals after the first 4 monthly doses. Aflibercept Q8W after the first 5 monthly doses.	Vabysmo (Q8W): N=317 Vabysmo variable dosing N=319 Aflibercept: N=315		

In both studies, patients were randomized in a 1:1:1 ratio to one of the three treatment regimens:

- Vabysmo 6 mg every 8 weeks (Q8W) after the first 6 monthly doses.
- Vabysmo 6 mg variable dosing: patients received Vabysmo 6 mg every 4 weeks for at least 4 doses and until resolution of edema based on the central subfield thickness (CST) of the macula measured by optical coherence tomography was achieved, then the interval of dosing was modified by up to 4 week interval extensions or reductions in 4 or 8 week interval decrements based on CST and visual acuity evaluation at study drug dosing visits.
- Aflibercept 2 mg every 8 weeks (Q8W) after the first 5 monthly doses.

The primary efficacy endpoint was the mean change in BCVA from baseline based on an average at Weeks 48, 52 and 56 (i.e., Year 1), as measured by the Early Treatment Diabetic Retinopathy Study (ETDRS) letter score. Additional secondary endpoint was the proportion of patients gaining ≥ 15 letters in BCVA from baseline based on an average at Weeks 48, 52 and 56.

In both studies (YOSEMITE and RHINE), non-inferiority of Vabysmo Q8W compared to aflibercept Q8W and of Vabysmo variable dosing compared to aflibercept Q8W was demonstrated using mean change in BCVA from baseline at Year 1, respectively. The results are summarized in **Table 8** and in **Figure 3** and **Figure 4** below.

At Week 52, in the Vabysmo variable dosing arm, 21% and 20% of patients achieved a Q12W dosing interval, and 53% and 51% of patients achieved a Q16W dosing interval in YOSEMITE and RHINE, respectively. Of the patients on Q16W at Week 52, 70% and 82% of patients maintained Q16W dosing without an interval reduction through Week 96 in YOSEMITE and RHINE, respectively. At Week 96, in the Vabysmo variable dosing arm, 60% and 64% of patients achieved a Q16W, 18% and 14% of patients achieved a Q12W dosing interval in YOSEMITE and RHINE, respectively. 4% and 6% of patients were extended to Q8W and stayed on \leq Q8W dosing intervals through Week 96; 3% and 5% received only Q4W dosing in YOSEMITE and RHINE through Week 96, respectively.

Table 8 Efficacy outcomes at Year 1^{ab} in YOSEMITE and RHINE

Efficacy Outcomes	YOSEMITE			RHINE		
	Vabysmo Q8W N = 315	Vabysmo variable dosing N = 313	Aflibercept Q8W N = 312	Vabysmo Q8W N = 317	Vabysmo variable dosing N = 319	Aflibercept Q8W N = 315
Mean BCVA (SD) at baseline	62.0 (9.9)	61.9 (10.2)	62.2 (9.5)	61.9 (10.1)	62.5 (9.3)	62.1 (9.4)
Mean change in BCVA from baseline as measured by ETDRS letter score (97.5% CI Year 1)	10.7 (9.4, 12.0)	11.6 (10.3, 12.9)	10.9 (9.6, 12.2)	11.8 (10.6, 13.0)	10.8 (9.6, 11.9)	10.3 (9.1, 11.4)
Difference in LS mean (97.5% CI)	-0.2 (-2.0, 1.6) ^b	0.7 (-1.1, 2.5) ^b		1.5 (-0.1, 3.2) ^b	0.5 (-1.1, 2.1) ^b	
Proportion of patients who gained at least 15 letters in BCVA from baseline ^c	29.2% (23.9%, 34.5%)	35.5% (30.1%, 40.9%)	31.8% (26.6%, 37.0%)	33.8% (28.4%, 39.2%)	28.5% (23.6%, 33.3%)	30.3% (25.0%, 35.5%)
Difference in % (95% CI)	-2.6% (-10.0%, 4.9%)	3.5% (-4.0%, 11.1%)		3.5% (-4.0%, 11.1%)	-2.0% (-9.1%, 5.2%)	

^aAverage of Weeks 48, 52 and 56

^bMet the pre-specified non-inferiority margin of 4 letters for the primary endpoint in both studies

^cCochran-Mantel-Haenszel weighted proportion

BCVA: Best Corrected Visual Acuity; ETDRS: Early Treatment Diabetic Retinopathy Study; CI: Confidence Interval; LS: Least Square

Figure 3 Mean change in BCVA from baseline to Year 2 (Week 100) in YOSEMITE

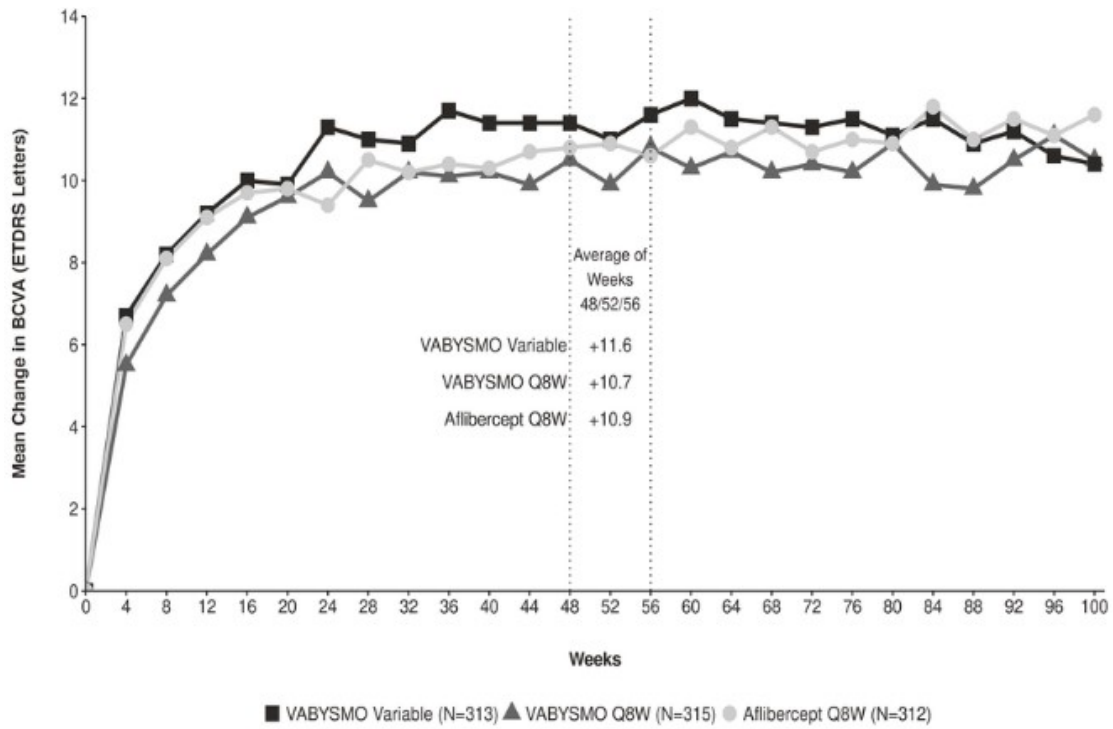
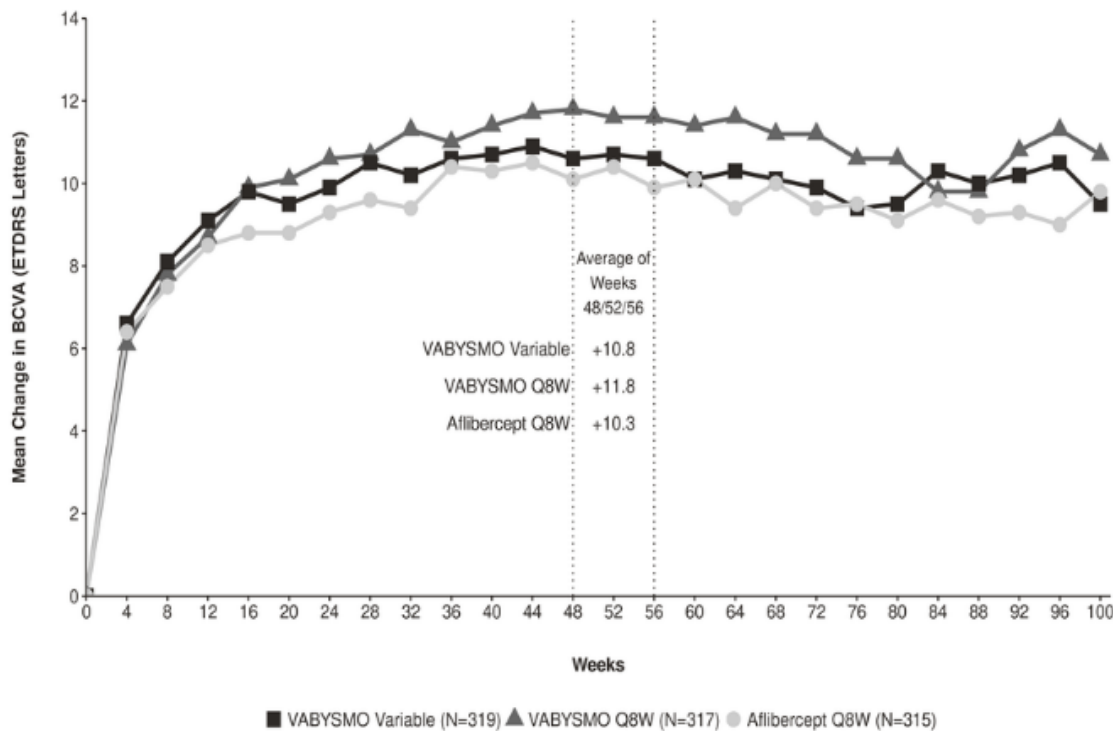

Figure 4 Mean change in BCVA from baseline to Year 2 (Week 100) in RHINE



At Year 2 (average of Weeks 92, 96 and 100), the mean change in BCVA from baseline was 10.7, 10.7, and 11.4 letters for patients receiving Vabysmo Q8W, Vabysmo variable dosing, or aflibercept Q8W, respectively, in YOSEMITE; the results were 10.9, 10.1, and 9.4 letters in RHINE. The proportions of patients who gained at least 15 letters in BCVA from baseline at Year 2 in YOSEMITE were 37%, 38% and 37% for patients receiving Vabysmo Q8W, Vabysmo variable dosing, or aflibercept Q8W, respectively; the results in RHINE were 40%, 31% and 39%, respectively.

Treatment of Macular Edema Secondary to RVO

The safety and efficacy of Vabysmo were assessed in two randomised, multi-centre, double-masked, studies in patients with macular edema secondary to BRVO (BALATON) or CRVO/HRVO (COMINO). Active comparator-controlled data are available through month 6.

A total of 1,282 patients (553 in BALATON and 729 in COMINO) were enrolled in the two studies, with 1,276 patients treated with at least one dose through week 24 (641 with Vabysmo).

Table 9 Summary of patient demographics for clinical trials in RVO

Study #	Study design	Dosage, route of administration and duration	Study subjects (n)	Mean age (Range)	Sex
GR41984 (BALATON)	Randomized, multi-center, double-masked, studies	Vabysmo 6 mg Q4W for six consecutive monthly doses	Vabysmo (Q4W) for six monthly doses: N=276	64.1 (28-93 years)	Male: 49.4% Female: 50.6 %
			Aflibercept (Q4W) for six monthly doses: N=277		
GR41986 (COMINO)		Aflibercept 2 mg Q4W for six consecutive monthly doses	Vabysmo (Q4W) for six monthly doses: N=366	65.1 (22-100 years)	Male: 53.9 % Female: 46.1 %
			Aflibercept (Q4W) for six monthly doses: N=363		

In both studies, patients were randomized in a 1:1 ratio to one of two treatment arms:

- Vabysmo 6 mg Q4W for six consecutive monthly doses
- Aflibercept 2 mg Q4W for six consecutive monthly doses

In both studies the primary endpoint was the change from baseline in BCVA at week 24, as measured by the ETDRS Letter Score. In both studies, Vabysmo Q4W treated patients had a non-inferior mean change from baseline in BCVA at week 24, compared to patients treated with aflibercept Q4W.

Detailed results of both studies are shown in **Table 10**, **Figure 5** and **Figure 6** below.

Table 10 Efficacy outcomes at the week 24 visit in BALATON and COMINO

Efficacy Outcomes	BALATON		COMINO	
	Vabysmo N = 276	Aflibercept N = 277	Vabysmo N = 366	Aflibercept N = 363
Mean BCVA (SD) at baseline	57.5 (13.0)	57.6 (12.2)	50.3 (16.3)	50.7 (16.3)
Mean change in BCVA as measured by ETDRS letter score from baseline (95% CI)	16.9 (15.7, 18.1)	17.5 (16.3, 18.6)	16.9 (15.4, 18.3)	17.3 (15.9, 18.8)
Difference in LS mean (95% CI) ^a	-0.6 (-2.2, 1.1) ^b		-0.4 (-2.5, 1.6) ^b	

^a: Estimated using MMRM. Missing data were implicitly imputed by MMRM

^b: Met the pre-specified non-inferiority margin of 4 letters for the primary endpoint in both studies

BCVA: Best Corrected Visual Acuity

ETDRS: Early Treatment Diabetic Retinopathy Study

CI: Confidence Interval

LS: Least Square

At week 24, the proportion of patients with ≥ 15 letter gain from baseline was 56% in the faricimab arm and 60% in the aflibercept arm, and 56% in the faricimab arm and 58% in the aflibercept arm, in the BALATON and COMINO studies, respectively.

Figure 5 Mean change in visual acuity from baseline to week 24 in BALATON

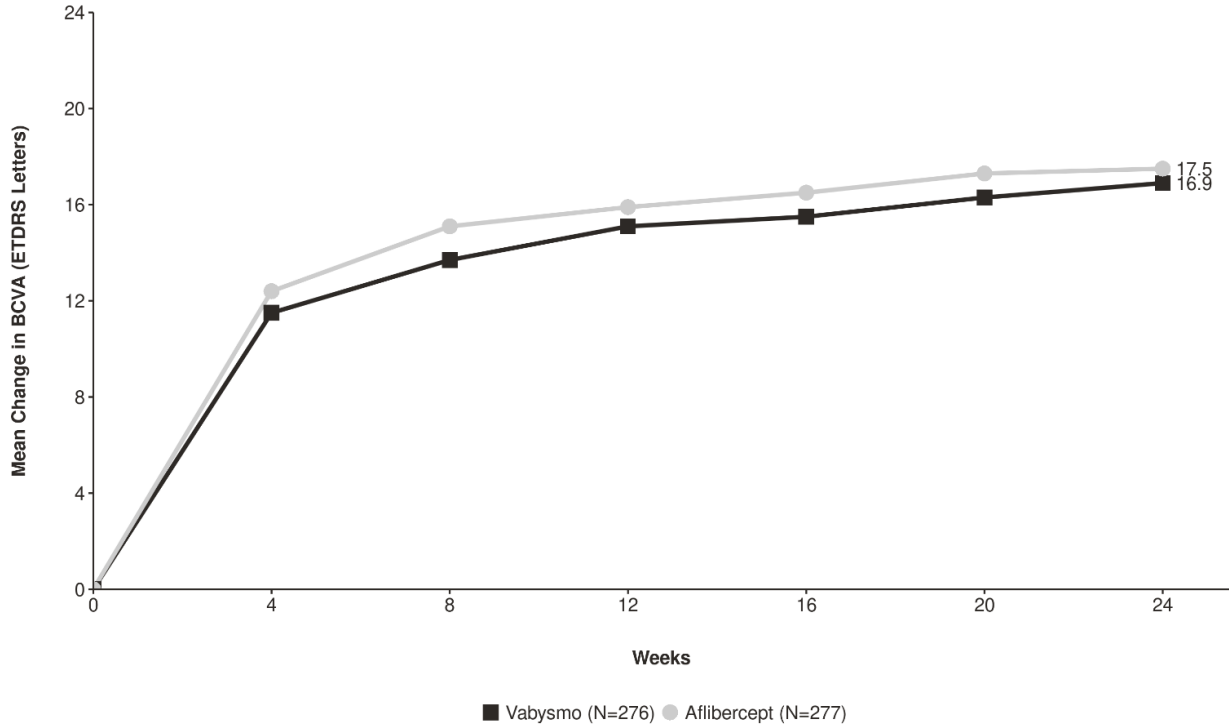
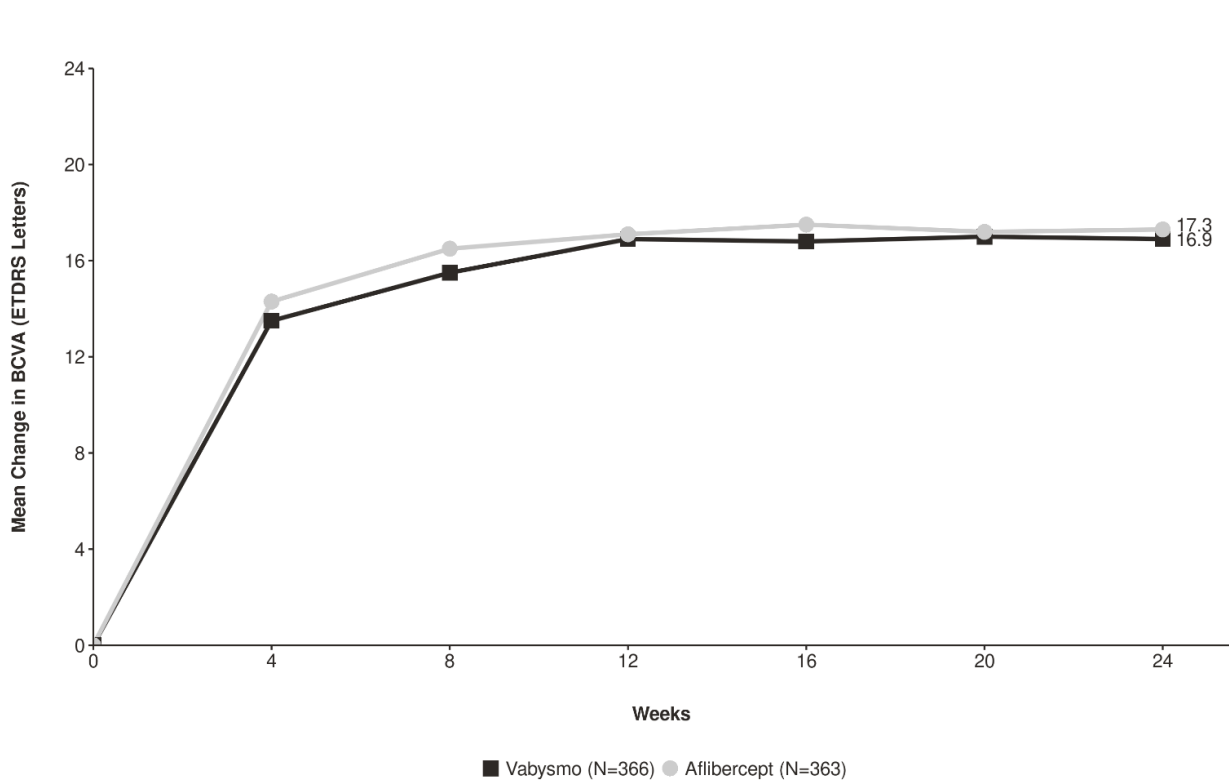

Figure 6 Mean change in visual acuity from baseline to week 24 in COMINO



14.4 Immunogenicity

Immunogenicity assay results are highly dependent on several factors including assay sensitivity and specificity, assay methodology, sample handling, timing of sample collection, concomitant medications and underlying disease. For these reasons, comparison of incidence of antibodies to Vabysmo with the incidence of antibodies to other products may be misleading.

As with all therapeutic proteins, there is a potential for an immune response in patients treated with Vabysmo (see 7 **WARNINGS AND PRECAUTIONS**). After dosing with Vabysmo for up to 112 (wet AMD), 100 (DME) and 24 (RVO) weeks, treatment emergent anti-faricimab antibodies were detected in approximately 91 out of 660 (13.8%), 120 out of 1252 (9.6%) and 48 out of 597 (8.0%) of patients randomized to faricimab respectively.

Intraocular inflammation adverse reactions were observed in 12 out of 98 (12.2%, wet AMD), 15 out of 128 (11.7%, DME) and 1 out of 54 (1.9%, RVO) ADA-positive patients and in 8 out of 562 (1.4%, wet AMD), 5 out of 1124 (0.4%, DME) and 7 out of 543 (1.3%, RVO) ADA-negative patients randomized to faricimab, respectively.

15 MICROBIOLOGY

No microbiological information is required for this drug product.

16 NON-CLINICAL TOXICOLOGY

General Toxicology: The toxicology program of faricimab included 2-, 9-, and 26-week repeat-dose ITV toxicity studies in cynomolgus monkeys. Unilateral intravitreal administration of faricimab to cynomolgus monkeys at doses between 0.5 mg/eye and 3.0 mg/eye once every 4 weeks for up to 26 weeks (6 months) resulted in dose-dependent ocular inflammation. At the no observed adverse effect level (NOAEL) of 0.5 mg per eye in cynomolgus monkeys, the systemic exposure (AUC) was 1.5 times higher than the exposure observed in humans after the recommended intravitreal dose of 6 mg/eye. The observed ocular inflammation was consistent with immune-mediated complex formation. Faricimab did not appear to affect the retinal function or cause significant changes in intraocular pressure (IOP). Assessments after the 13 weeks recovery period indicated recovery from faricimab-induced ocular inflammation.

Carcinogenicity: No studies have been conducted to establish the carcinogenic potential of faricimab.

Genotoxicity: No studies have been conducted to establish the mutagenic potential of faricimab.

Reproductive and Developmental Toxicology: No fertility studies or reproductive toxicity testing of faricimab have been conducted.

In a 6-month cynomolgus monkey study with faricimab doses of up to 3 mg/eye, no treatment-related changes were noted in reproductive organs in male or female animals that denote adverse effects on fertility.

VEGF inhibition has been shown to cause malformations, embryo-fetal resorption, and decreased fetal weight. VEGF inhibition has also been shown to affect follicular development, corpus luteum function, and fertility. No dedicated studies addressing the effects of Ang-2 inhibition on pregnancy are available; however, based on non-clinical information, Ang-2 inhibition may lead to effects comparable to VEGF inhibition.

In an embryo-fetal development study, no treatment-related maternal changes or fetal developmental effects were observed in pregnant cynomolgus monkeys given 5 weekly IV injections of faricimab at

1 mg/kg or 3 mg/kg starting on day 20 up to day 48 of gestation. The no observed adverse effect level (NOAEL) was determined to be 3 mg/kg, the highest dose tested (523 times the clinical exposure based on the Cmax at the maximum recommended human dose of a single 6 mg/eye intravitreal dose).

PATIENT MEDICATION INFORMATION

READ THIS FOR SAFE AND EFFECTIVE USE OF YOUR MEDICINE

PrVABYSMO®

faricimab injection

Read this carefully before you start taking **Vabysmo** and each time you get a refill. This leaflet is a summary and will not tell you everything about this drug. Talk to your healthcare professional about your medical condition and treatment and ask if there is any new information about **Vabysmo**.

What is Vabysmo used for?

- Vabysmo is a medicine that is injected into the eye by your doctor to treat eye disorders called
 - neovascular (wet) age-related macular degeneration (AMD)
 - diabetic macular edema (DME)
 - macular edema secondary to retinal vein occlusion (RVO)

How does Vabysmo work?

Vabysmo specifically recognizes and blocks the activity of proteins known as angiopoietin-2 and vascular endothelial growth factor A. In conditions like wet AMD, DME, and RVO, these proteins can be present at high levels, and this can cause the growth of abnormal blood vessels, damage to the normal vessels and/or blockage of the blood vessels. These changes to the blood vessels can result in leakage into the retina causing swelling or damage to the retina, which can worsen your vision. By attaching to these proteins, Vabysmo can block their actions and prevent abnormal vessel growth, leakage, swelling and blockage. Vabysmo may improve disease and/or slow down worsening of the disease meaning it can maintain or even improve your vision.

What are the ingredients in Vabysmo?

Medicinal ingredients: faricimab

Non-medicinal ingredients: acetic acid 30%, D-sucrose, L-histidine, L-methionine, polysorbate 20, sodium chloride, water for injections.

Vabysmo comes in the following dosage forms:

Solution for intravitreal injection in single-use pre-filled syringe or single-use vial.

Pre-filled Syringe: A single-use glass pre-filled syringe contains 21 mg faricimab in 0.175 mL solution. This provides a usable amount to deliver a single dose of 0.05 mL solution containing 6 mg of faricimab.

Vial: A single-use glass vial contains 28.8 mg faricimab in 0.24 mL solution. This provides a usable amount to deliver a single dose of 0.05 mL solution containing 6 mg of faricimab.

Do not use Vabysmo if:

- you have an active or suspected infection in or around the eye.
- you have pain or redness in your eye (eye inflammation).
- you are allergic to faricimab or any of the other ingredients in Vabysmo (see **What are the ingredients in Vabysmo?**).

If any of these apply to you, tell your doctor. You should not be given Vabysmo.

To help avoid side effects and ensure proper use, talk to your healthcare professional before you take Vabysmo. Talk about any health conditions or problems you may have, including if you:

- have glaucoma (an eye condition usually caused by high pressure in the eye).
- have a history of seeing flashes of light or floaters (dark floating spots) and if you have a sudden increase in the size and number of floaters.
- have had eye surgery in the last four weeks or if eye surgery is planned in the next four weeks.
- have ever had any eye diseases or eye treatments.
- have had a stroke or experienced transient signs of stroke (weakness or paralysis of limbs or face, difficulty speaking or understanding).
- are pregnant or planning to become pregnant.
- are breast-feeding.

During treatment with Vabysmo, tell your doctor immediately if you:

- develop signs of detachment or tear of the retina at the back of the eye, such as sudden vision loss, flashing lights and black spots.
- develop signs of a possible eye infection or inflammation, such as redness of the eye or worsening redness of the eye, eye pain, increased eye discomfort, blurred or decreased vision, an increased number of small particles in your vision, increased sensitivity to light.
- develop signs of a possible retinal vasculitis (inflammation of the vessels of the retina) and/or retinal occlusive vasculitis (blockage in a vein that drains blood from your retina), such as blurred or decreased vision, an increased number of small particles in your vision, eye pain, redness of the eye or worsening redness of the eye, increased eye discomfort, or black spots in your vision.
- develop signs of a cataract (clouding of the lens of the eye), such as clouded, blurred or dim vision.
- develop signs of a possible allergic reaction (for example, fast pulse, low blood pressure, sweating, allergic skin reactions such as rash, itching or stinging).

Other warnings you should know about:

- The safety and efficacy of Vabysmo given to both eyes at the same time has not been studied and use in this way may lead to an increased risk of experiencing side effects.
- Injections with Vabysmo may cause a temporary increase in eye pressure (intraocular pressure) in some patients within 60 minutes of the injection. Your doctor will monitor this after each injection.
- Your doctor will check whether you have other risk factors that may increase the chance of a tear or detachment of one of the layers at the back of the eye (retinal detachment or tear, and retinal pigment epithelial detachment or tear), in which case Vabysmo must be given with caution.
- The use of vascular endothelial growth factor inhibitors, substances similar to those contained in Vabysmo, is potentially related to the risk of blood clots blocking blood vessels (arterial

thromboembolic events), which may lead to heart attack or stroke. There could be a risk of such events following injection of Vabysmo into the eye.

Children and adolescents (< 18 years)

Vabysmo is **NOT** used in children and adolescents.

Pregnancy, breastfeeding and contraception

Vabysmo has not been studied in pregnant women. Vabysmo should be avoided during pregnancy unless the potential benefit to the patient outweighs the potential risk to the unborn child. If you are pregnant, think you may be pregnant or are planning to have a baby, ask your doctor for advice before starting Vabysmo treatment.

Breastfeeding is not recommended during treatment with Vabysmo because it is not known whether Vabysmo passes into human milk. A risk to the breast-fed child cannot be excluded. You should not breastfeed your child during Vabysmo treatment, and for at least one month after the last injection when stopping treatment with Vabysmo. Ask your doctor for advice before starting Vabysmo treatment. A decision must be made whether to discontinue breast-feeding or to abstain from Vabysmo therapy.

Women who could become pregnant must use an effective method of birth control during treatment and for at least three months after stopping treatment with Vabysmo. If you become pregnant or think you are pregnant during treatment, tell your doctor right away.

Driving and using machines

After your injection with Vabysmo, you may have temporary vision problems (for example, blurred vision). Do not drive or use machines as long as these last.

Tell your healthcare professional about all the medicines you take, including any drugs, vitamins, minerals, natural supplements or alternative medicines.

How to take Vabysmo:

- Vabysmo is injected into your eye (intravitreal injection) by a doctor experienced in giving eye injections.
- Before the injection, your doctor will use a disinfectant eyewash to clean your eye carefully to prevent infection. Your doctor will give you an eye drop (local anesthetic) to numb the eye to reduce or prevent pain from the injection.

Usual dose:

The recommended dose is 6 mg of faricimab.

Your doctor will determine how often you will need to get an injection.

wet AMD

- You will be treated with one injection every month for the first 4 months.
- After that, you may receive injections up to every 4 months. Your doctor will determine how often you will need treatment (your treatment interval) based on the condition of your eye.

DME

- You will be treated with one injection every month for the first 4 months.
- After that, you may receive injections up to every 4 months. Your doctor will determine how

often you need treatment (your treatment interval) based on the condition of your eye.

RVO

- You will be treated with one injection every month for 6 months.

Your doctor will regularly monitor your condition to check that the treatment is working for you. Your doctor may also check your eyes during a visit and not give you an injection.

Speak with your doctor before stopping treatment. Stopping treatment may increase your risk of vision loss and your vision may worsen.

If you have any further questions on the use of this medicine, ask your doctor.

Overdose:

If you think you, or a person you are caring for, has been given too much Vabysmo, contact a healthcare professional, hospital emergency department, or regional poison control centre immediately, even if there are no symptoms.

Missed Dose:

If you miss a dose, schedule a new appointment with your doctor as soon as possible.

What are possible side effects from using Vabysmo?

These are not all the possible side effects you may feel when taking Vabysmo. The side effects with the Vabysmo injection are either from the medicine itself or from the injection procedure and they mostly affect the eye. If you experience any side effects not listed here, tell your healthcare professional.

Contact your doctor if any of the following side effects become severe.

Very common (may affect more than 1 in 10 people):

- None

Common (may affect up to 1 in 10 people):

- Cloudy lens in the eye (cataract)
- Detachment of the gel-like substance inside the eye (vitreous detachment)
- Bleeding from small blood vessels in the outer layer of the eye (conjunctival hemorrhage)
- Moving spots or dark shapes in your vision (vitreous floaters)
- Eye pain

Uncommon (may affect up to 1 in 100 people):

- Eye discomfort
- Itching (eye pruritus)
- Red eye (ocular/conjunctival hyperemia)
- A feeling of having something in the eye (foreign body sensation in eye)
- Pain during the procedure (procedural pain)
- Increased tear production (lacrimation increased)

- Scratched cornea, damage to the clear layer of the eyeball that covers the iris (corneal abrasion)
- Eye irritation

Rare (may affect up to 1 in 1000 people):

- Temporary decreased sharpness of vision (visual acuity reduced transiently)

Serious side effects and what to do about them			
Symptom / effect	Talk to your healthcare professional		Stop taking drug and get immediate medical help
	Only if severe	In all cases	
COMMON			
Cataract (clouded, blurred or dim vision)		✓	
Tear of one of the layers in the back of the eye (retinal pigment epithelial tear, a sudden decrease or change in vision, wet AMD only)		✓	
Increased pressure in the eye		✓	
UNCOMMON			
Inflammation or infections (redness of the eye, eye pain, increased eye discomfort, blurred or decreased vision, increased number of small particles in your vision, increased sensitivity to light)		✓	
Tear or detachment of one of the layers at the back of the eye (the retina) (a sudden decrease or change in vision, flashing lights, black spots)		✓	
Signs of stroke (weakness or paralysis of limbs or face, difficulty speaking or understanding, sudden blurring or loss of vision)*		✓	
Disturbed or blurred vision		✓	
Bleeding in the eye		✓	
Shock (hypersensitivity) – fast pulse, low blood pressure, sweating		✓	
UNKNOWN			
Retinal vasculitis (inflammation of the vessels of the retina) and/or retinal occlusive vasculitis		✓	

Serious side effects and what to do about them			
Symptom / effect	Talk to your healthcare professional		Stop taking drug and get immediate medical help
	Only if severe	In all cases	
(blockage in a vein that drains blood from your retina)			

* There is a potential risk of Arterial Thromboembolic Events (ATEs), including stroke, following injection of Vabysmo into the eye.

If you have a troublesome symptom or side effect that is not listed here or becomes bad enough to interfere with your daily activities, talk to your healthcare professional.

Reporting Side Effects

You can report any suspected side effects associated with the use of health products to Health Canada by:

- Visiting the Web page on Adverse Reaction Reporting (<https://www.canada.ca/en/health-canada/services/drugs-health-products/medeffect-canada.html>) for information on how to report online, by mail or by fax; or
- Calling toll-free at 1-866-234-2345.

NOTE: Contact your health professional if you need information about how to manage your side effects. The Canada Vigilance Program does not provide medical advice.

Storage:

- Keep out of reach and sight of children.
- Do not use this medicine after the expiry date which is stated on the carton and label after EXP. The expiry date refers to the last day of that month.
- Store in a refrigerator (2°C to 8°C).
- Do not freeze. Do not shake.
- Keep the sealed tray containing the pre-filled syringe or vial in the outer carton in order to protect from light.
- Prior to use, the sealed tray containing the pre-filled syringe or unopened vial may be kept at room temperature (up to 25°C), in the original carton, for up to 24 hours.
- Vabysmo is for single use only. Any unused product or waste material should be disposed of in accordance with local requirements.

If you want more information about Vabysmo:

- Talk to your healthcare professional
- Find the full product monograph that is prepared for healthcare professionals and includes this Patient Medication Information by visiting the Health Canada website: (<https://www.canada.ca/en/health-canada/services/drugs-health-products/drug-products/drug-product-database.html>); the manufacturer's website (www.rochecanada.com), or by calling 1-888-

762-4388.

This leaflet was prepared by Hoffmann-La Roche Limited.

Last Revised: December 13, 2024

©Copyright 2024, Hoffmann-La Roche Limited

VABYSMO® is a registered trademark of F. Hoffmann-La Roche AG, used under license



Hoffmann-La Roche Limited
Mississauga, ON L5N 5M8