

**Product Monograph**  
**Including Patient Medication Information**

**PrDENOZA™**

Denosumab injection

60 mg / 1 mL solution for subcutaneous  
injection

Prefilled Syringe

Professed Standard

RANK Ligand Inhibitor  
(Bone Metabolism Regulator)

Apotex Inc.  
150 Signet Drive  
Toronto, Ontario  
M9L 1T9

Date of Authorization:

March 11, 2026

Control Number: 289109

**Recent Major Label Changes**

Not applicable	
----------------	--

**Table of Contents**

Certain sections or subsections that are not applicable at the time of preparation of the most recent authorized product monograph are not listed.

**Recent Major Label Changes ..... 2**

**Table of Contents..... 2**

**Part 1: Healthcare Professional Information..... 5**

**1 Indications ..... 5**

    1.1 Pediatrics ..... 6

    1.2 Geriatrics ..... 6

**2 Contraindications..... 6**

**4 Dosage and Administration..... 6**

    4.1 Dosing Considerations ..... 6

    4.2 Recommended Dose and Dosage Adjustment ..... 7

        4.2.1 Discontinuing Treatment..... 7

    4.4 Administration ..... 7

    4.5 Missed Dose ..... 8

**5 Overdose ..... 8**

**6 Dosage Forms, Strengths, Composition, and Packaging ..... 8**

**7 Warnings and Precautions ..... 8**

    General ..... 8

    Carcinogenesis and Genotoxicity ..... 9

    Endocrine and Metabolism ..... 9

    Hepatic/Biliary/Pancreatic..... 9

    Immune ..... 9

    Monitoring and Laboratory Tests ..... 10

    Musculoskeletal..... 10

    Renal ..... 12

Skin .....	12
7.1 Special Populations.....	12
7.1.1 Pregnancy.....	12
7.1.2 Breastfeeding .....	13
7.1.3 Pediatrics.....	13
7.1.4 Geriatrics.....	14
<b>8 Adverse Reactions .....</b>	<b>15</b>
8.1 Adverse Reaction Overview .....	15
8.2 Clinical Trial Adverse Reactions.....	15
8.3 Less Common Clinical Trial Adverse Reactions (< 1%) .....	45
8.4 Abnormal Laboratory Findings: Hematologic, Clinical Chemistry and Other Quantitative Data .....	48
8.5 Post-Market Adverse Reactions .....	48
<b>9 Drug Interactions .....</b>	<b>49</b>
9.2 Drug Interactions Overview .....	49
9.3 Drug-Behaviour Interactions.....	50
9.4 Drug-Drug Interactions .....	50
9.5 Drug-Food Interactions .....	50
9.6 Drug-Herb Interactions .....	50
9.7 Drug-Laboratory Test Interactions .....	50
<b>10 Clinical Pharmacology .....</b>	<b>50</b>
10.1 Mechanism of Action.....	50
10.2 Pharmacodynamics.....	51
10.3 Pharmacokinetics.....	51
10.4 Immunogenicity .....	54
<b>11 Storage, Stability, and Disposal .....</b>	<b>54</b>
<b>Part 2: Scientific Information.....</b>	<b>55</b>
<b>13 Pharmaceutical Information.....</b>	<b>55</b>
<b>14 Clinical Trials.....</b>	<b>55</b>
14.1 Clinical Trials by Indication .....	55
Treatment of Osteoporosis in Postmenopausal Women.....	55

Treatment to Increase Bone Mass in Men with Osteoporosis at High Risk for Fracture . 60

Treatment to Increase Bone Mass in Men with Nonmetastatic Prostate Cancer receiving Androgen Deprivation Therapy (ADT), Who Are at High Risk for Fracture ..... 61

Treatment to Increase Bone Mass in Women Receiving Adjuvant AI Therapy for Nonmetastatic Breast Cancer Who Have Low Bone Mass and Are at High Risk for Fracture ..... 62

Treatment and Prevention of Glucocorticoid-Induced Osteoporosis (GIOP) in Men and Women at High Risk for Fracture ..... 63

**15 Microbiology..... 65**

**16 Non-Clinical Toxicology ..... 65**

**17 Supporting Product Monographs..... 74**

**Patient Medication Information ..... 75**

## Part 1: Healthcare Professional Information

DENOZA™ (denosumab injection) is a biosimilar biologic drug (biosimilar) to PROLIA® (denosumab injection). A biosimilar is a biologic drug that was granted authorization based on a demonstration of similarity to a version previously authorized in Canada, known as the reference biologic drug.

### 1 Indications

Indications have been granted on the basis of similarity between DENOZA and the reference biologic drug PROLIA®.

DENOZA (denosumab injection) is indicated:

- **Postmenopausal Osteoporosis**

for the treatment of postmenopausal women with osteoporosis at high risk for fracture, defined as a history of osteoporotic fracture, or multiple risk factors for fracture; or patients who have failed or are intolerant to other available osteoporosis therapy. In postmenopausal women with osteoporosis, DENOZA reduces the incidence of vertebral, nonvertebral and hip fractures (see [14 Clinical Trials](#)).

- **Treatment to Increase Bone Mass in Men with Osteoporosis at High Risk for Fracture**

as a treatment to increase bone mass in men with osteoporosis at high risk for fracture, defined as a history of osteoporotic fracture, or multiple risk factors for fracture; or patients who have failed or are intolerant to other available osteoporosis therapy (see [14 Clinical Trials](#)).

- **Treatment to Increase Bone Mass in Men with Nonmetastatic Prostate Cancer receiving Androgen Deprivation Therapy (ADT), who are at high risk for fracture**

as a treatment to increase bone mass in men with nonmetastatic prostate cancer receiving androgen deprivation therapy (ADT), who are at high risk for fracture (see [14 Clinical Trials](#)).

- **Treatment to Increase Bone Mass in Women Receiving Adjuvant Aromatase Inhibitor Therapy for Nonmetastatic Breast Cancer**

as a treatment to increase bone mass in women with nonmetastatic breast cancer receiving adjuvant aromatase inhibitor (AI) therapy, who have low bone mass and are at high risk for fracture (see [14 Clinical Trials](#)).

- **Treatment to Increase Bone Mass for the Treatment and Prevention of Glucocorticoid-Induced Osteoporosis in Women and Men at High Risk for Fracture**

- as a treatment to increase bone mass in women and men at high risk for fracture due to sustained systemic glucocorticoid therapy (see [14 Clinical Trials](#)).
- as a treatment to increase bone mass in women and men at high risk for fracture who are starting or have recently started long term glucocorticoid therapy (see [14 Clinical](#)

[Trials](#)).

### 1.1 Pediatrics

**Pediatrics (< 18 years of age):** Based on the data submitted and reviewed by Health Canada, the safety and efficacy of denosumab in pediatric patients has not been established; therefore, Health Canada has not authorized an indication for pediatric use (see [7 Warnings and Precautions, Special Populations, Pediatrics](#)).

### 1.2 Geriatrics

**Geriatrics (≥ 65 years of age):** The majority of patients treated with denosumab in the postmenopausal osteoporosis (PMO) clinical trial were ≥ 65 years old (see [7 Warnings and Precautions, Special Populations, Geriatrics](#)).

- Of the patients in the osteoporosis study in men, 133 patients (55%) were ≥ 65 years old, while 39 patients (16%) were ≥ 75 years old.
- In the clinical trial of men with bone loss associated with ADT for nonmetastatic prostate cancer, 1364 patients (93%) were ≥ 65 years old.
- In a clinical trial of women with bone loss associated with adjuvant AI therapy for breast cancer, 76 patients (30%) were ≥ 65 years old.
- In a clinical trial of patients with glucocorticoid-induced osteoporosis, 355 patients (44.7%) were ≥ 65 years old.

## 2 Contraindications

- DENOZA is contraindicated in patients who are hypersensitive to this drug or to any ingredient in the formulation, including any non-medicinal ingredient, or component of the container. For a complete listing, see [6 Dosage Forms, Strengths, Composition, and Packaging](#). Anaphylactic reactions have been reported (see [7 Warnings and Precautions, Immune, Hypersensitivity](#) and [8 Adverse Reactions, Post-Market Adverse Reactions](#)).
- Hypocalcemia (see [7 Warnings and Precautions, Endocrine and Metabolism, Hypocalcemia](#))
- Female patients who are pregnant or who are trying to become pregnant. DENOZA may cause fetal harm when administered to a pregnant woman. In women of reproductive potential, pregnancy testing should be performed prior to initiating treatment with DENOZA. In utero denosumab exposure in cynomolgus monkeys resulted in increased fetal loss, stillbirths, and postnatal mortality, along with evidence of absent lymph nodes, abnormal bone growth and decreased neonatal growth. If this drug is used during pregnancy, or if the patient becomes pregnant while taking this drug, the patient should be apprised of the potential hazard to a fetus (see [7 Warnings and Precautions, Special Populations, Pregnancy](#)).

## 4 Dosage and Administration

### 4.1 Dosing Considerations

DENOZA is intended for use under the guidance and supervision of physicians who have fully familiarized themselves with the efficacy/safety profile of DENOZA. After an initial training in proper subcutaneous injection technique, patients may self-inject DENOZA if a physician determines that is appropriate and with medical follow-up as necessary. Patients should be informed that serious hypersensitivity reactions including anaphylaxis have been reported with denosumab injections.

Pregnancy must be ruled out prior to administration of DENOZA. Perform pregnancy testing in all women of reproductive potential prior to administration of DENOZA. Based on findings in animals, denosumab may cause fetal harm when administered to pregnant women (see [2 Contraindications](#), [7 Warnings and Precautions](#) and [16 Non-Clinical Toxicology, General Toxicology](#)).

Patients must be adequately supplemented with calcium and vitamin D at the recommended doses<sup>a</sup>.

## 4.2 Recommended Dose and Dosage Adjustment

Health Canada has not authorized an indication for pediatric use (see [7 Warnings and Precautions, Special Populations, Pediatrics](#)).

The recommended dose of DENOZA (denosumab) is a single SC injection of 60 mg, once every 6 months.

### 4.2.1 Discontinuing Treatment

#### Multiple Vertebral Fractures (MVF) Following Discontinuation of Denosumab Treatment

Multiple vertebral fractures (MVF) may occur following discontinuation of treatment with denosumab, particularly in patients with a history of vertebral fracture.

Advise patients not to interrupt OBODENCE therapy without their physician's advice. Evaluate the individual benefit-risk before discontinuing treatment with OBODENCE. If OBODENCE treatment is discontinued, consider transitioning to an alternative antiresorptive therapy.

## 4.4 Administration

Administration of DENOZA should be performed by an individual who has been adequately trained in injection techniques.

The prefilled syringe is not made with natural rubber latex.

Parenteral drug products should be inspected visually for particulate matter and discoloration prior to administration, whenever solution and container permit. DENOZA is a colourless to yellowish solution. Do not use if the solution is cloudy.

Prior to administration, DENOZA may be allowed to reach room temperature (up to 25°C) in the original carton. This generally takes about 30 minutes.

---

<sup>a</sup> 2010 clinical practice guidelines for the diagnosis and management of osteoporosis in Canada: summary

Administer DENOZA via SC injection in the upper arm, the upper thigh, or the abdomen.

#### 4.5 Missed Dose

If a dose is missed, it should be given as soon as convenient. The next dose should be scheduled 6 months from the date of the previous injection.

#### 5 Overdose

There is no experience with overdosage with DENOZA.

For the most recent information in the management of a suspected drug overdose, contact your regional poison control centre or Health Canada's toll-free number, 1-844 POISON-X (1-844-764-7669).

#### 6 Dosage Forms, Strengths, Composition, and Packaging

To help ensure the traceability of biologic products, healthcare professionals should record both the brand name and the non-proprietary (active ingredient) name as well as other product-specific identifiers such as the Drug Identification Number (DIN) and the batch/lot number of the product supplied.

Route of Administration	Dosage Form / Strength/Composition	Non-Medicinal Ingredients
Subcutaneous	Solution for injection / 60 mg denosumab in 1 mL solution in a single use prefilled syringe (PFS)	Acetic acid, polysorbate 20, sodium hydroxide, sorbitol, and water for injection (USP).

DENOZA is a sterile, preservative-free, colourless to yellowish solution formulated at pH 5.2.

DENOZA is supplied in a single use prefilled syringe with a safety guard. The prefilled syringe is not made with natural rubber latex.

Each 1.0 mL single use prefilled syringe of DENOZA contains 60 mg denosumab, 46.0 mg (4.6%) sorbitol, 1.1 mg (18 mM) acetic acid, 0.1 mg (0.01%) polysorbate 20, water for injection (USP), and sodium hydroxide to a pH of 5.2.

DENOZA is supplied in a dispensing pack containing one prefilled syringe.

#### 7 Warnings and Precautions

##### General

Adequate intake of calcium and vitamin D is important in all patients.

Patients being treated with DENOZA should not be treated concomitantly with other

denosumab-containing medicinal products.

## **Carcinogenesis and Genotoxicity**

### ***Malignancies***

See [8 Adverse Reactions, Clinical Trial Adverse Reactions](#).

## **Endocrine and Metabolism**

### ***Hypercalcemia in Pediatric Patients with Osteogenesis Imperfecta***

DENOZA is not indicated for use in pediatric patients.

In clinical trials, hypercalcemia has been reported in pediatric patients with osteogenesis imperfecta treated with denosumab. Some cases required hospitalization (see [Special Populations, Pediatrics](#)).

### ***Hypocalcemia***

Hypocalcemia must be corrected by adequate intake of calcium and vitamin D prior to initiating therapy with DENOZA. Other disorders affecting mineral metabolism (such as vitamin D deficiency) should be treated.

Clinical monitoring of calcium levels is recommended before each dose and, in patients predisposed to hypocalcemia within two weeks after the initial dose (see [Monitoring and Laboratory Tests](#)).

Patients are advised to report to their physicians any symptoms of hypocalcemia, such as paresthesias or muscle spasms, twitching and muscle cramps ([8 Adverse Reactions, Hypocalcemia](#)). Calcium levels should be measured if any patient presents with suspected symptoms of hypocalcemia during treatment.

In the postmarket setting, severe symptomatic hypocalcemia (resulting in hospitalization, life-threatening events, and fatal cases) has been reported, particularly in patients with severe renal impairment, receiving dialysis or treatment with other calcium lowering drugs (see [8 Adverse Reactions, Post-Market Adverse Reactions, Severe Hypocalcemia](#)). While most cases occurred in the first weeks of initiating therapy, it can also occur later. Examples of the clinical manifestations of severe symptomatic hypocalcemia have included QT interval prolongation, tetany, convulsions and altered mental status.

## **Hepatic/Biliary/Pancreatic**

The safety and efficacy of DENOZA have not been studied in patients with hepatic impairment.

## **Immune**

### ***Hypersensitivity***

Clinically significant hypersensitivity reactions including anaphylaxis have been reported with denosumab. Symptoms have included hypotension, dyspnea, throat tightness, facial and upper airway edema, pruritus, and urticaria.

If an anaphylactic or other clinically significant allergic reaction occurs, initiate appropriate treatment immediately and discontinue further use of DENOZA (see [2 Contraindications](#) and [8 Adverse Reactions](#)).

### ***Infections***

In a 3-year clinical trial in women with postmenopausal osteoporosis, serious infections leading to hospitalization were reported more frequently in the denosumab group (4.1%) than in the placebo group (3.4%). Skin infections leading to hospitalization were reported more frequently in the denosumab (0.4%) versus the placebo (< 0.1%) groups. These cases were predominantly cellulitis. As well, infections of the abdomen, urinary tract, and ear, were more frequent in patients treated with denosumab. Endocarditis was also reported more frequently in denosumab-treated patients (< 0.1% denosumab group; 0% placebo group). The incidence of opportunistic infections was balanced between denosumab and placebo groups and the overall incidence of skin infections was similar between the denosumab (1.5%) and placebo (1.2%) groups. Patients should be advised to seek prompt medical attention if they develop signs or symptoms of severe infection, including cellulitis and erysipelas (see [8 Adverse Reactions, Infections](#)).

Patients on concomitant immunosuppressant agents (eg, glucocorticoids) or with impaired immune systems may be at increased risk for serious infections. Limited information is available on the safety of denosumab treatment in patients with glucocorticoid-induced osteoporosis who have a clinically important active infection, or a history of recurrent or chronic infections. Consider the benefit-risk profile in such patients before treating with DENOZA. In patients who develop serious infections while on DENOZA, prescribers should assess the need for continued DENOZA therapy.

### **Monitoring and Laboratory Tests**

Clinical monitoring of calcium is recommended before each dose. In patients with a history of hypocalcemia, or signs and symptoms of hypocalcemia or predisposed to hypocalcemia (eg, history of hypoparathyroidism, thyroid surgery, parathyroid surgery, malabsorption syndromes, excision of small intestine, severe renal impairment [creatinine clearance < 30 mL/min] or receiving dialysis, or treatment with other calcium lowering drugs), clinical monitoring of calcium levels is recommended within the first 2 weeks of the initial dose. Calcium levels should be measured if any patient presents with suspected symptoms of hypocalcemia during treatment (see [7 Warnings and Precautions, Endocrine and Metabolism, Hypocalcemia](#)).

### **Musculoskeletal**

#### ***Osteonecrosis of the Jaw (ONJ)***

Osteonecrosis of the jaw (ONJ) has been reported in patients treated with denosumab or bisphosphonates, another class of anti-resorptive agents. Most cases have been in cancer patients; however, some have occurred in patients with osteoporosis. The risk of ONJ may increase with duration of exposure to DENOZA. ONJ has been reported in clinical studies in patients receiving denosumab at a dose of 60 mg every 6 months for osteoporosis. There have been reports of ONJ in clinical studies in patients with advanced cancer treated with denosumab

at the studied dose of 120 mg administered every 4 weeks.

Known risk factors for ONJ include previous treatment with bisphosphonates, older age, smoking, a diagnosis of cancer, concomitant therapies (eg, chemotherapy, antiangiogenic biologics, corticosteroids, radiotherapy to head and neck), poor oral hygiene, invasive dental procedures (eg, dental extractions, dental implants, oral surgery), and co-morbid disorders (eg, periodontal and/or other pre-existing dental disease, ill-fitting dentures, anemia, coagulopathy, infection).

It is important to evaluate patients for risk factors for ONJ before starting treatment. A dental examination with appropriate preventative dentistry is recommended prior to treatment with DENOZA in patients with risk factors for ONJ.

Good oral hygiene practices should be maintained during treatment with DENOZA. Patients should receive routine dental check-ups, and immediately report any oral symptoms such as dental mobility, pain or swelling during treatment with DENOZA.

Avoid invasive dental procedures during treatment with DENOZA. For patients in whom invasive dental procedures cannot be avoided, the clinical judgment of the treating physician should guide the management plan of each patient based on individual benefit-risk assessment.

Patients who are suspected of having ONJ or patients who develop ONJ during treatment with DENOZA should receive care by a dentist or an oral surgeon. In patients who develop ONJ during treatment with DENOZA, a temporary interruption of treatment should be considered based on individual benefit-risk assessment until the condition resolves (see [8 Adverse Reactions, Osteonecrosis of the Jaw \(ONJ\)](#)).

### ***Atypical Femoral Fractures***

Atypical femoral fractures have been reported in patients receiving denosumab. Atypical femoral fractures may occur with little or no trauma in the subtrochanteric and diaphyseal regions of the femur and may be bilateral. Specific radiographic findings characterize these events. Atypical femoral fractures have also been reported in patients with certain comorbid conditions (eg, vitamin D deficiency, rheumatoid arthritis, hypophosphatasia) and with use of certain pharmaceutical agents (eg, bisphosphonates, glucocorticoids, proton pump inhibitors). These events have also occurred without antiresorptive therapy. During DENOZA treatment, patients should be advised to report new or unusual thigh, hip, or groin pain. Patients presenting with such symptoms should be evaluated for an incomplete femoral fracture, and the contralateral femur should also be examined.

### ***Suppression of Bone Turnover***

In clinical trials in women with postmenopausal osteoporosis, treatment with denosumab resulted in significant suppression of bone remodeling as evidenced by markers of bone turnover and bone histomorphometry. The significance of these findings and the effect of long-term treatment with denosumab are unknown. Monitor patients for osteonecrosis of the jaw, atypical fractures, and delayed fracture healing (see [8 Adverse Reactions, Fracture Healing, Osteonecrosis of the Jaw \(ONJ\)](#); [10 Clinical Pharmacology, Pharmacodynamics](#); [14 Clinical Trials, Bone Histology and Histomorphometry](#)).

## Renal

In a study of 55 patients with varying degrees of renal function, including patients on dialysis, the degree of renal impairment had no effect on the pharmacokinetics of denosumab; thus, dose adjustment for renal impairment is not necessary.

In clinical studies, patients with severe renal impairment (creatinine clearance < 30 mL/min) or receiving dialysis were at greater risk of developing hypocalcemia. Adequate intake of calcium and vitamin D is important in patients with severe renal impairment or receiving dialysis (see [7 Warnings and Precautions, Endocrine and Metabolism, Hypocalcemia](#)).

## Skin

In a large, 3-year clinical trial of over 7800 women with postmenopausal osteoporosis, epidermal and dermal adverse events such as dermatitis, eczema, and rashes occurred at a significantly higher rate in the denosumab (10.8%) group compared to the placebo (8.2%) group. Most of these events were not specific to the injection site. Consider discontinuing DENOZA if severe symptoms develop (see [8 Adverse Reactions, Skin](#)).

### 7.1 Special Populations

#### 7.1.1 Pregnancy

There have been no studies of denosumab in pregnant women.

DENOZA is contraindicated in pregnant women and in women trying to conceive. Verify the pregnancy status of women of reproductive potential prior to initiating DENOZA treatment. Advise women of reproductive potential of the risk of DENOZA use in pregnancy and to use effective contraception during therapy; and for at least 5 months after the last dose of DENOZA.

Denosumab may cause fetal harm when administered to a pregnant woman based on findings in animal studies (see [2 Contraindications](#), [4 Dosage and Administration](#) and [16 Non-Clinical Toxicology, General Toxicology](#)).

Developmental toxicity studies have been performed in cynomolgus monkeys at AUC exposures of up to 100-fold higher than the human exposure. No evidence of impaired fertility was observed.

In a study of cynomolgus monkeys dosed with denosumab during the period equivalent to the first trimester at AUC exposures up to 99-fold higher than the human dose (60 mg every 6 months), there was no evidence of maternal or fetal harm. In this study, fetal lymph nodes were not examined.

In another study, in utero denosumab exposure in cynomolgus monkeys at 50 mg/kg body weight every 4 weeks, from gestation day 20 through to parturition resulted in increased fetal loss, stillbirths and post-natal mortality. Findings in the infants included skeletal abnormalities resulting from impaired bone resorption during rapid growth, reduced bone strength and treatment-related bone fractures; reduced hematopoiesis; tooth malalignment and dental dysplasia (in the absence of adverse effects on tooth eruption); absence of peripheral lymph nodes; and decreased neonatal growth. There was no evidence of maternal toxicity. Maternal

mammary gland development was normal.

Studies in mice suggest absence of RANKL during pregnancy may interfere with maturation of the mammary gland leading to impaired lactation postpartum (see [16 Non-Clinical Toxicology, General Toxicology](#)).

## Males

In healthy men administered a single dose of denosumab, denosumab was present in the seminal fluid at maximum concentrations corresponding to approximately 0 to 5% of that present in serum. It is unlikely that a female partner or embryo/fetus would be exposed to pharmacologically relevant concentrations of denosumab via seminal fluid following unprotected sexual intercourse with a male partner treated with DENOZA ([10 Clinical Pharmacology, Pharmacokinetics](#)).

### 7.1.2 Breastfeeding

DENOZA is not recommended for use in nursing women (see also [Pediatrics](#) below). It is not known whether denosumab is excreted into human milk. Because DENOZA has the potential to cause adverse reactions in nursing infants, a decision should be made whether to discontinue nursing or discontinue the drug.

### 7.1.3 Pediatrics

**Pediatrics (< 18 years of age):** Based on the data submitted and reviewed by Health Canada, the safety and efficacy of denosumab in pediatric patients has not been established; therefore, Health Canada has not authorized an indication for pediatric use.

In clinical trials, hypercalcemia has been reported very commonly in pediatric patients with osteogenesis imperfecta treated with denosumab. Some cases required hospitalization and were complicated by acute renal injury (see [7 Warning and Precautions, Endocrine and Metabolism](#)).

Adolescent primates (cynomolgus monkeys) dosed with denosumab at 27 and 150 times (10 and 50 mg/kg dose) the clinical exposure based on AUC had abnormal growth plates. In neonatal rats, inhibition of RANKL (target of denosumab therapy) with a construct of osteoprotegerin bound to Fc (OPG-Fc) at high doses was associated with inhibition of bone growth and tooth eruption. Therefore, treatment with DENOZA may inhibit bone growth in children with open growth plates and may inhibit eruption of dentition. In neonatal cynomolgus monkeys exposed in utero to denosumab at 50 mg/kg, there was increased post-natal mortality; skeletal abnormalities resulting from impaired bone resorption during rapid growth, reduced bone strength and treatment-related bone fractures; reduced hematopoiesis; tooth malalignment and dental dysplasia (in the absence of adverse effects on tooth eruption); absence of peripheral lymph nodes; and decreased neonatal growth. Following a recovery period from birth out to 6 months of age, findings still observed were mildly reduced bone length (femoral, vertebral, jaw), reduced cortical thickness with associated reduced strength; extramedullary hematopoiesis; dental dysplasia; and the absence or decreased size of some lymph nodes. One infant had minimal to moderate mineralization in multiple tissues (see [16](#)

[Non-Clinical Toxicology, General Toxicology](#)).

#### 7.1.4 Geriatrics

##### Geriatrics (≥ 65 years of age)

###### Females

In the PMO clinical trial, 94.7% of the patients who received denosumab were ≥ 65 years old and 31.6% were ≥ 75 years old. No overall differences in safety or efficacy were observed between patients ≥ 65 years old and patients ≥ 75 years old. Other reported clinical experience has not identified differences in responses between the elderly and younger patients, but greater sensitivity of some older individuals cannot be ruled out.

In a clinical trial of women with bone loss associated with adjuvant AI therapy for breast cancer, 30% of the patients who received denosumab were ≥ 65 years old.

In a clinical trial of patients with glucocorticoid-induced osteoporosis, 248 (44.6%) of the female subjects were ≥ 65 years old.

###### Males

In the male osteoporosis trial, no overall differences in efficacy were observed in patients ≥ 65 years of age (N = 133) who received denosumab, compared with younger patients. However, greater sensitivity of some older individuals cannot be ruled out.

There were 133 patients (55%) ≥ 65 years of age, of whom 39 patients (16%) were ≥ 75 years. The incidence of adverse events (AEs) in patients ≥ 65 and ≥ 75 years of age were 107 events in 50 patients (73.5%) and 30 events in 14 patients (70.0%) in the denosumab group vs. 124 events in 43 patients (67.2%) and 45 events in 12 patients (63.2%) in the placebo group, respectively; the incidence of serious adverse events (SAEs) were 14 events in 10 patients (14.7%) and 5 events in 4 patients (20.0%) in the denosumab group vs. 8 events in 6 patients (9.4%) and 1 event in 1 patient (5.3%) in the placebo group, respectively. The incidence of AEs in patients < 65 years of age were 61 events in 36 patients (69.2%) in the denosumab group vs. 100 events in 41 patients (73.2%) in the placebo group; the incidence of SAEs in patients < 65 years of age were 2 events in 1 patient (1.9%) in the denosumab group vs. 5 events in 4 patients (7.1%) in the placebo group.

In the clinical trial of men with bone loss associated with ADT for nonmetastatic prostate cancer, 93% of the patients who received denosumab were ≥ 65 years old. No overall differences in safety or efficacy were observed between these patients and younger patients.

In a clinical trial of patients with glucocorticoid-induced osteoporosis, 107 (44.8%) of the male subjects were ≥ 65 years old.

For men with sexual partners who could become pregnant, see also [Special Populations, Pregnancy](#) and [Special Populations, Males](#).

##### Information to be Provided to the Patient

Patients must be adequately supplemented with calcium and vitamin D. All patients should be

instructed on the importance of calcium and vitamin D supplementation in maintaining serum calcium levels. Patients should be advised to seek prompt medical attention if they develop signs or symptoms of hypocalcemia (eg, paresthesias or muscle spasms) (see [Patient Medication Information](#)).

Patients should be advised to seek prompt medical attention if they develop signs or symptoms of cellulitis.

Patients should be aware of the most commonly associated side effects of denosumab therapy.

If a dose of DENOZA is missed, the injection should be administered as soon as convenient. Thereafter, injections should be scheduled every 6 months from the date of the last injection.

## **8 Adverse Reactions**

### **8.1 Adverse Reaction Overview**

A total of 8091 women (4050 denosumab vs. 4041 placebo) were enrolled in placebo-controlled studies of women with postmenopausal osteoporosis or low bone mass (Study 1 and Study 2), and a total of 242 men (121 denosumab vs. 121 placebo) were enrolled in a placebo-controlled study of men with osteoporosis (Study 5). A total of 1468 men (734 denosumab vs. 734 placebo) were enrolled in a placebo-controlled study of bone loss in men with nonmetastatic prostate cancer receiving androgen deprivation therapy (ADT) (Study 6). A total of 252 women (127 denosumab vs. 125 placebo) were enrolled in a placebo-controlled study of bone loss in women with breast cancer receiving adjuvant aromatase inhibitor (AI) therapy (Study 7). A total of 795 patients, 70% women and 30% men, (398 denosumab vs. 397 risedronate) were enrolled in an active controlled study of glucocorticoid-induced osteoporosis (Study 8).

### **8.2 Clinical Trial Adverse Reactions**

Clinical trials are conducted under very specific conditions. Therefore, the frequencies of adverse reactions observed in the clinical trials; may not reflect frequencies observed in clinical practice and should not be compared to frequencies reported in clinical trials of another drug.

#### **Treatment of Postmenopausal Osteoporosis**

The safety of denosumab in the treatment of postmenopausal osteoporosis was assessed in a large, 3-year, randomized, double-blind, placebo-controlled, multinational study of 7808 postmenopausal women aged 60 to 91 years with osteoporosis (Study 1). A total of 3876 women received placebo and 3886 women received denosumab administered once every 6 months as a single 60 mg subcutaneous (SC) dose. All women received calcium (at least 1000 mg) and vitamin D (at least 400 IU) supplementation per day.

The incidence of adverse events was 93% in both treatment groups (n = 3605 in the denosumab group and 3607 in the placebo group).

- The 3 most common adverse events overall were back pain (1347 [34.7%] denosumab, 1340 [34.6%] placebo), arthralgia (784 [20.2%] denosumab, 782 [20.2%] placebo), and hypertension (614 [15.8%] denosumab, 636 [16.4%] placebo).

- The most common adverse events (> 5% and more common than placebo) were back pain (1347 [34.7%] denosumab, 1340 [34.6%] placebo), pain in extremity (453 [11.7%] denosumab, 430 [11.1%] placebo), hypercholesterolemia (280 [7.2%] denosumab, 236 [6.1%] placebo), musculoskeletal pain (297 [7.6%] denosumab, 291 [7.5%] placebo) and cystitis (228 [5.9%] denosumab, 225 [5.8%] placebo).

The incidence of serious adverse events was 25.8% (n = 1004) in the denosumab group and 25.1% (n = 972) in the placebo group.

- The 3 most common serious adverse events were osteoarthritis (63 [1.6%] denosumab, 79 [2.0%] placebo), atrial fibrillation (36 [0.9%] denosumab, 33 [0.9%] placebo), and pneumonia (34 [0.9%] denosumab, 36 [0.9%] placebo). Deaths occurred in 70 subjects (1.8%) in the denosumab group and 90 subjects (2.3%) in the placebo group. Adverse events leading to treatment discontinuation occurred in 192 (4.9%) women in the denosumab group and 202 (5.2%) women in the placebo group.
- The 3 most common adverse events leading to treatment discontinuation were breast cancer (including patients with a history of breast cancer) (20 [0.5%] denosumab, 10 [0.3%] placebo), back pain (6 [0.2%] denosumab, 10 [0.3%] placebo), and constipation (6 [0.2%] denosumab, 6 [0.2%] placebo). Cardiac disorders leading to discontinuation were reported in 14 patients (0.4%) in the denosumab group and 3 patients (< 0.1%) in the placebo group.

Adverse events reported in  $\geq 1\%$  of postmenopausal women with osteoporosis are shown in [Table 1](#).

**Table 1. Adverse Events Occurring in  $\geq 1\%$  of Patients with Postmenopausal Osteoporosis**

<b>SYSTEM ORGAN CLASS</b> Preferred Term	<b>denosumab</b> <b>(N = 3886)</b> <b>n (%)</b>	<b>Placebo</b> <b>(N = 3876)</b> <b>n (%)</b>
<b>BLOOD AND LYMPHATIC SYSTEM DISORDERS</b>		
Anemia	129 (3.3)	107 (2.8)
<b>CARDIAC DISORDERS</b>		
Angina pectoris	101 (2.6)	87 (2.2)
Atrial fibrillation	79 (2.0)	77 (2.0)
Palpitations	59 (1.5)	59 (1.5)
Cardiac failure	53 (1.4)	38 (1.0)
Arrhythmia	41 (1.1)	41 (1.1)
<b>EAR AND LABYRINTH DISORDERS</b>		
Vertigo	195 (5.0)	187 (4.8)
Tinnitus	35 (0.9)	55 (1.4)
<b>ENDOCRINE DISORDERS</b>		
Hypothyroidism	62 (1.6)	59 (1.5)
<b>EYE DISORDERS</b>		
Cataract	229 (5.9)	253 (6.5)

**Table 1. Adverse Events Occurring in  $\geq 1\%$  of Patients with Postmenopausal Osteoporosis**

<b>SYSTEM ORGAN CLASS</b> Preferred Term	<b>denosumab</b> <b>(N = 3886)</b> <b>n (%)</b>	<b>Placebo</b> <b>(N = 3876)</b> <b>n (%)</b>
Glaucoma	59 (1.5)	64 (1.7)
Conjunctivitis	48 (1.2)	59 (1.5)
<b>GASTROINTESTINAL DISORDERS</b>		
Constipation	355 (9.1)	361 (9.3)
Diarrhea	228 (5.9)	236 (6.1)
Dyspepsia	178 (4.6)	212 (5.5)
Nausea	178 (4.6)	193 (5.0)
Abdominal pain	146 (3.8)	149 (3.8)
Abdominal pain upper	129 (3.3)	111 (2.9)
Gastritis	99 (2.5)	109 (2.8)
Vomiting	91 (2.3)	93 (2.4)
Flatulence	84 (2.2)	53 (1.4)
Gastroesophageal reflux disease	80 (2.1)	66 (1.7)
Hemorrhoids	55 (1.4)	50 (1.3)
Hiatus hernia	49 (1.3)	56 (1.4)
<b>GENERAL DISORDERS AND ADMINISTRATION SITE CONDITIONS</b>		
Edema peripheral	189 (4.9)	155 (4.0)
Fatigue	115 (3.0)	127 (3.3)
Asthenia	90 (2.3)	73 (1.9)
Noncardiac chest pain	84 (2.2)	90 (2.3)
Pain	47 (1.2)	55 (1.4)
Pyrexia	45 (1.2)	40 (1.0)
<b>HEPATOBIILIARY DISORDERS</b>		
Cholelithiasis	52 (1.3)	69 (1.8)
<b>INFECTIONS AND INFESTATIONS</b>		
Nasopharyngitis	563 (14.5)	600 (15.5)
Influenza	331 (8.5)	335 (8.6)
Bronchitis	301 (7.7)	301 (7.8)
Urinary tract infection	245 (6.3)	253 (6.5)
Cystitis	228 (5.9)	225 (5.8)
Upper respiratory tract infection	190 (4.9)	167 (4.3)
Pneumonia	152 (3.9)	150 (3.9)
Sinusitis	101 (2.6)	121 (3.1)
Pharyngitis	91 (2.3)	78 (2.0)
Gastroenteritis	81 (2.1)	94 (2.4)
Herpes zoster	79 (2.0)	72 (1.9)

**Table 1. Adverse Events Occurring in  $\geq 1\%$  of Patients with Postmenopausal Osteoporosis**

<b>SYSTEM ORGAN CLASS</b> Preferred Term	<b>denosumab</b> <b>(N = 3886)</b> <b>n (%)</b>	<b>Placebo</b> <b>(N = 3876)</b> <b>n (%)</b>
Lower respiratory tract infection	69 (1.8)	86 (2.2)
Viral infection	66 (1.7)	72 (1.9)
Rhinitis	63 (1.6)	84 (2.2)
Respiratory tract infection	55 (1.4)	69 (1.8)
Ear infection	43 (1.1)	21 (0.5)
Tooth infection	26 (0.7)	41 (1.1)
<b>INJURY, POISONING AND PROCEDURAL COMPLICATIONS</b>		
Fall	205 (5.3)	250 (6.4)
Contusion	162 (4.2)	192 (5.0)
Radius fracture	104 (2.7)	116 (3.0)
Joint sprain	60 (1.5)	65 (1.7)
Procedural pain	57 (1.5)	54 (1.4)
Humerus fracture	42 (1.1)	49 (1.3)
Rib fracture	40 (1.0)	33 (0.9)
Ulna fracture	37 (1.0)	39 (1.0)
Foot fracture	34 (0.9)	39 (1.0)
Lumbar vertebral fracture	25 (0.6)	72 (1.9)
Thoracic vertebral fracture	22 (0.6)	53 (1.4)
<b>INVESTIGATIONS</b>		
Weight decreased	41 (1.1)	49 (1.3)
<b>METABOLISM AND NUTRITION DISORDERS</b>		
Hypercholesterolemia	280 (7.2)	236 (6.1)
Diabetes mellitus	62 (1.6)	58 (1.5)
Hyperlipidemia	45 (1.2)	35 (0.9)
<b>MUSCULOSKELETAL AND CONNECTIVE TISSUE DISORDERS</b>		
Back pain	1347 (34.7)	1340 (34.6)
Arthralgia	784 (20.2)	782 (20.2)
Pain in extremity	453 (11.7)	430 (11.1)
Osteoarthritis	436 (11.2)	442 (11.4)
Musculoskeletal pain	297 (7.6)	291 (7.5)
Muscle spasms	167 (4.3)	182 (4.7)
Bone pain	142 (3.7)	117 (3.0)
Neck pain	129 (3.3)	136 (3.5)
Myalgia	114 (2.9)	94 (2.4)
Spinal osteoarthritis	82 (2.1)	64 (1.7)

**Table 1. Adverse Events Occurring in  $\geq 1\%$  of Patients with Postmenopausal Osteoporosis**

<b>SYSTEM ORGAN CLASS</b> Preferred Term	<b>denosumab</b> <b>(N = 3886)</b> <b>n (%)</b>	<b>Placebo</b> <b>(N = 3876)</b> <b>n (%)</b>
Musculoskeletal chest pain	61 (1.6)	63 (1.6)
Tendonitis	56 (1.4)	47 (1.2)
Joint swelling	55 (1.4)	66 (1.7)
Arthritis	48 (1.2)	53 (1.4)
<b>NERVOUS SYSTEM DISORDERS</b>		
Headache	237 (6.1)	258 (6.7)
Dizziness	217 (5.6)	218 (5.6)
Sciatica	178 (4.6)	149 (3.8)
Syncope	67 (1.7)	71 (1.8)
Paresthesia	63 (1.6)	56 (1.4)
Memory impairment	52 (1.3)	37 (1.0)
<b>PSYCHIATRIC DISORDERS</b>		
Depression	213 (5.5)	221 (5.7)
Insomnia	126 (3.2)	122 (3.1)
Anxiety	123 (3.2)	123 (3.2)
<b>RENAL AND URINARY DISORDERS</b>		
Urinary incontinence	39 (1.0)	40 (1.0)
Renal cyst	23 (0.6)	39 (1.0)
<b>RESPIRATORY, THORACIC AND MEDIASTINAL DISORDERS</b>		
Cough	224 (5.8)	238 (6.1)
Dyspnea	93 (2.4)	105 (2.7)
Asthma	66 (1.7)	65 (1.7)
Pharyngolaryngeal pain	52 (1.3)	67 (1.7)
Chronic obstructive pulmonary disease	38 (1.0)	39 (1.0)
<b>SKIN AND SUBCUTANEOUS TISSUE DISORDERS</b>		
Rash	96 (2.5)	79 (2.0)
Pruritus	87 (2.2)	82 (2.1)
Eczema	50 (1.3)	25 (0.6)
Alopecia	31 (0.8)	41 (1.1)
<b>VASCULAR DISORDERS</b>		
Hypertension	614 (15.8)	636 (16.4)
Varicose vein	58 (1.5)	60 (1.5)
Hematoma	38 (1.0)	51 (1.3)

N = Number of subjects who received  $\geq 1$  dose of investigational product

n = Number of subjects reporting  $\geq 1$  event

Includes only treatment-emergent adverse events

### **Hypocalcemia**

In postmenopausal women with osteoporosis in Study 1, declines of serum calcium concentrations to less than the normal range were reported in 15 (0.4%) women in the placebo group and 63 (1.6%) women in the denosumab group. Declines of serum calcium concentrations to < 7.5 mg/dL (< 1.88 mmol/L) were reported in 2 (< 0.1%) women in the placebo group and (< 0.1%) in the denosumab group. In clinical studies, subjects with impaired renal function were more likely to have greater reductions in serum calcium levels compared to subjects with normal renal function. In a study of 55 patients with varying degrees of renal function who did not receive calcium and vitamin D supplementation, symptomatic hypocalcemia or serum calcium levels < 7.5 mg/dL was observed in 5 subjects, including no subjects in the normal renal function group, 10% (1 out of 10) of subjects in the CrCL 50 to 80 mL/min group, 29% (2 out of 7) of subjects in the CrCL < 30 mL/min group, and 29% (2 out of 7) of subjects in the hemodialysis group (see [7 Warnings and Precautions](#)).

### **Infections**

Receptor activator of nuclear factor kappa-B ligand (RANKL) is expressed on activated T and B lymphocytes and in lymph nodes. Therefore, a RANKL inhibitor such as denosumab may increase the risk of infection. In the clinical study of 7808 postmenopausal women with osteoporosis, the incidence of infections resulting in death was 6 (0.2%) in both placebo and denosumab treatment groups. The incidence of nonfatal serious infections was 3.3% (n = 128) in the placebo group and 4.0% (n = 154) in the denosumab group. Hospitalizations due to serious infections in the abdomen 28 (0.7%) placebo vs. 36 (0.9%) denosumab, urinary tract 20 (0.5%) placebo vs. 29 (0.7%) denosumab, and ear 0 (0.0%) placebo vs. 5 (0.1%) denosumab were reported. Endocarditis was reported in 0 (0.0%) placebo patients and 3 (0.1%) patients receiving denosumab.

Overall skin infections leading to hospitalization were reported more frequently in patients treated with denosumab (2 [< 0.1%] placebo vs. 15 [0.4%] denosumab) among women with postmenopausal osteoporosis in Study 1. These events were predominantly comprised of erysipelas (0 [0%] placebo and 7 [0.2%] denosumab) and cellulitis (1 [< 0.1%] placebo and 6 [0.2%] denosumab) (see [7 Warnings and Precautions](#)).

The overall incidence of infections was similar between the denosumab and placebo groups (2055 [52.9%] denosumab, 2108 [54.4%] placebo). The incidence of specific infection types was as follows: urinary tract infections (245 [6.3%] denosumab, 253 [6.5%] placebo), upper respiratory infections (190 [4.9%] denosumab, 167 [4.3%] placebo), ear infections (43 [1.1%] denosumab, 21 [0.5%] placebo), and diverticulitis (28 [0.7%] denosumab, 22 [0.6%] placebo).

There was no imbalance in the reporting of opportunistic infections (4 [0.1%] denosumab, 3 [0.1%] placebo).

### **Skin**

A significantly higher number of patients treated with denosumab developed epidermal and dermal adverse events (such as dermatitis, eczema, and rashes), with these events reported in 8.2% (n = 316) of placebo and 10.8% (n = 421) of denosumab group (p < 0.0001). Most of these events were not specific to the injection site (see [7 Warnings and Precautions, Skin](#)).

***Osteonecrosis of the Jaw (ONJ)***

ONJ has been reported rarely in the open-label osteoporosis clinical trial program in patients treated with denosumab (see [7 Warnings and Precautions](#)).

***Atypical Femoral Fracture***

In the osteoporosis clinical trial program, atypical femoral fractures were reported in patients treated with denosumab (see [7 Warnings and Precautions](#)).

***Multiple Vertebral Fractures (MVF) Following Discontinuation of denosumab Treatment***

In the osteoporosis clinical trial program, MVF were reported in patients following discontinuation of treatment with denosumab, particularly in those with a history of vertebral fracture.

***Cardiovascular Disorders***

The incidence of positively adjudicated cardiovascular serious adverse events was 186 (4.8%) denosumab and 178 (4.6%) placebo, with a hazard ratio (95% confidence interval) of 1.02 (0.83, 1.25). Adjudicated cardiovascular events were further sub-categorized as follows: cardiovascular death, acute coronary syndrome, stroke/transient ischemic attack, congestive heart failure, other vascular event, and arrhythmia. The incidence of these subcategories was 23 (0.6%) denosumab and 31 (0.8%) placebo for cardiovascular death, 47 (1.2%) denosumab and 39 (1.0%) placebo for acute coronary syndrome, 56 (1.4%) denosumab and 54 (1.4%) placebo for stroke/transient ischemic attack, 27 (0.7%) denosumab and 22 (0.6%) placebo for congestive heart failure, 31 (0.8%) denosumab and 30 (0.8%) placebo for other vascular event, and 52 (1.3%) denosumab and 45 (1.2%) placebo for arrhythmia.

***Fracture Healing***

Delayed fracture healing of nonvertebral fractures was reported in 2 out of 303 (0.7%) subjects in the denosumab group (3 out of 386 [0.8%] nonvertebral fractures) and 2 out of 364 (0.5%) subjects in the placebo group (2 out of 465 [0.4%] nonvertebral fractures). In addition, nonunion of nonvertebral fractures was reported in 0 out of 303 (0%) subjects in the denosumab group (0 out of 386 [0%] nonvertebral fractures) and 1 out of 364 (0.3%) subjects in the placebo group (1 out of 465 [0.2%] nonvertebral fractures). For fractures that occurred near the final study closure, additional follow-up after study closure identified 2 additional subjects in the placebo group and 0 in the denosumab group with delayed fracture healing. Of the subjects with a distal radius fracture, 1 out of 104 (1.0%) subjects in the denosumab group (1 out of 106 [0.9%] distal radius fractures) and 0 out of 116 (0%) subjects in the placebo group (0 out of 118 [0%] distal radius fractures) had delayed fracture healing.

***Malignancies***

The overall incidence of new malignancies was 188 (4.8%) in the denosumab and 166 (4.3%) in the placebo groups. The most common malignancies ( $\geq 0.2\%$ ) included: breast cancer (28 [0.7%] denosumab, 26 [0.7%] placebo), colon cancer (11 [0.3%] denosumab, 8 [0.2%] placebo), lung neoplasm malignant (9 [0.2%] denosumab, 9 [0.2%] placebo), gastric cancer (7 [0.2%] denosumab, 3 [0.1%] placebo), pancreatic carcinoma (7 [0.2%] denosumab, 3 [0.1%] placebo),

squamous cell carcinoma of skin (6 [0.2%] denosumab, 8 [0.2%] placebo), and recurrent breast cancer (6 [0.2%] denosumab, 2 [0.1%] placebo). Other malignancies reported include: thyroid cancer (2 [0.1%] denosumab, 0 [0%] placebo), carcinoid of the stomach (1 [ $< 0.1\%$ ] denosumab, 0 [0%] placebo), uterine cancer (3 [0.1%] denosumab, 1 [ $< 0.1\%$ ] placebo), ovarian cancer metastatic (2 [0.1%] denosumab, 0 [0%] placebo), ovarian epithelial cancer (2 [0.1%] denosumab, 0 [0%] placebo), vulval cancer (2 [0.1%] denosumab, 0 [0%] placebo), and lentigo maligna stage unspecified (3 [0.1%] denosumab, 0 [0%] placebo). A causal relationship to drug exposure has not been established.

### ***Hypersensitivity Reactions***

The incidence of adverse drug reactions potentially associated with hypersensitivity was 50 (1.3%) in the denosumab group and 50 (1.3%) in the placebo group. The most common adverse event potentially associated with hypersensitivity was urticaria (27 [0.7%] denosumab, 27 [0.7%] placebo).

### ***Pancreatitis***

Pancreatitis was reported in 4 patients (0.1%) in the placebo and 8 patients (0.2%) in the denosumab groups. Of these reports, one patient in the placebo group and all 8 patients in the denosumab group had serious events including 2 deaths in the denosumab group. Several patients had a prior history of pancreatitis or a confounding event (eg, gallstones). The time from product administration to event occurrence was variable.

### ***Laboratory Abnormalities***

The most frequent laboratory abnormalities were changes in serum calcium with compensatory physiological changes in serum phosphorus. The median percent change from baseline (interquartile range) at month 1 for serum calcium was -2.1% (-5.2% to 1.0%) for denosumab and 1.0% (-2.0% to 3.2%) for placebo. The median percent change from baseline (interquartile range) at month 1 for serum phosphorus was -8.3% (-15.8% to 0%) for denosumab and 0% (-5.6% to 8.3%) for placebo. Alkaline phosphatase was also reduced, by month 6, which reflects reduced osteoclast activity in bone, with a decrease from baseline of 25% in denosumab subjects compared to 3% to 8% in placebo subjects.

Serum phosphorous levels were between 2.0 and 2.5 mg/dL in 2.0% (n = 82) of patients in the placebo group and 7.0% (n = 263) of patients in the denosumab group. Decrease in platelet levels to between 50,000/mm<sup>3</sup> and 75,000/mm<sup>3</sup> was reported at 0.2% (n = 7) in the placebo group and 0.4% (n = 14) in the denosumab group, and decrease in platelet levels to  $< 25,000/\text{mm}^3$  was reported at  $< 0.1\%$  (n = 2) in the placebo group and at 0.1% (n = 4) in the denosumab group. Increase in aspartate aminotransferase (AST) levels to between 1.0 and 2.5 x the upper limit of normal (ULN) was reported at 5.0% (n = 206) in the placebo group and 7.0% (n = 264) in the denosumab group, and increase in alanine aminotransferase levels (ALT) to between 2.5 and 5.0 x ULN were reported at 0.5% (n = 21) in the placebo group and 1.0% (n = 37) in the denosumab group. Increase in total bilirubin value to between 3.0 and 10.0 x ULN was reported at 0.0% (n = 0) in the placebo group and 0.1% (n = 5) in the denosumab group.

### ***Long Term Safety in Postmenopausal Osteoporosis***

The safety of denosumab was assessed in clinical studies of up to 10 years in duration.

A total of 4550 patients who completed Study 1 (N = 7808) enrolled into a 7-year, multinational, multicenter, open label, single-arm extension study to evaluate the long-term safety and efficacy of denosumab. All patients in the extension study were to receive denosumab every 6 months as a single 60 mg SC dose, as well as daily calcium (1 g) and vitamin D (at least 400 IU).

Based on data from 7 years of the extension study for patients who received denosumab in Study 1 and continued on therapy (years 4 through 10 of denosumab treatment; N = 2343), the overall subject incidence rates of adverse events and serious adverse events reported (event rates per 100 patient-years) were similar to that observed in the initial 3 years of Study 1. For patients who crossed over to denosumab from placebo in Study 1 (N = 2206), the overall subject incidence rates of adverse events and serious adverse events reported (event rates per 100 patient-years) were also similar to that observed in the first 3 years of Study 1. Events of osteonecrosis of the jaw and atypical femoral fractures have been observed.

A summary of the safety results are provided in the following [Table 2](#).

**Table 2. Patient-year-adjusted Adverse Events Rates (per 100 Patient-years)**

	Placebo	denosumab		
	Study 1 Years 1-3 N = 3883 (Patient-year = 10738.8) Rate (Events)	Study 1 Years 1-3 N = 3879 (Patient-year = 10805.6) Rate (Events)	Cross-Over Extension Years 1-7 N = 2206 (Patient-year = 12082.7) Rate (Events)	Long-Term Extension Years 4- 10 N = 2343 (Patient-year = 12798.0) Rate (Events)
<b>All Adverse Events (AE)</b>	237.3 (25482)	235.1 (25406)	174.5 (21083)	174.8 (22374)
<b>Most Common AEs</b>				
Arthralgia	10.2 (1093)	10.3 (1112)	6.3 (765)	6.1 (778)
Back Pain	19.1 (2052)	19.0 (2053)	5.9 (710)	5.3 (676)
Hypertension	6.7 (723)	6.5 (701)	5.0 (604)	4.9 (629)
Nasopharyngitis	7.3 (782)	7.0 (751)	4.7 (565)	4.5 (576)
Osteoarthritis	5.5 (587)	4.8 (519)	4.4 (536)	4.7 (602)
Pain in extremity	5.2 (555)	5.6 (600)	2.8 (338)	3.0 (389)
<b>Serious Adverse Events</b>	16.4 (1758)	17.3 (1870)	17.2 (2080)	17.3 (2217)
<b>Deaths</b>	0.9 (92)	0.7 (72)	0.8 (102)	0.9 (111)
<b>Clinically Significant AEs</b>				

	Placebo	denosumab		
	Study 1 Years 1-3 N = 3883 (Patient-year = 10738.8) Rate (Events)	Study 1 Years 1-3 N = 3879 (Patient-year = 10805.6) Rate (Events)	Cross-Over Extension Years 1-7 N = 2206 (Patient-year = 12082.7) Rate (Events)	Long-Term Extension Years 4- 10 N = 2343 (Patient-year = 12798.0) Rate (Events)
Hypocalcemia	<0.1 (3)	0 (0)	<0.1 (10)	<0.1 (6)
Osteonecrosis of the Jaw	0 (0)	0 (0)	<0.1 (6)	<0.1 (7)
Atypical Femoral Fracture	0 (0)	0 (0)	<0.1 (1)	<0.1 (1)
Serious Infections	1.4 (152)	1.8 (191)	1.9 (230)	2.0 (253)
Infections	40.9 (4396)	40.6 (4385)	32.7 (3948)	33.6 (4296)
Malignancies	1.8 (191)	1.9 (210)	2.4 (291)	2.2 (287)
Delayed Fracture Healing	<0.1 (2)	<0.1 (1)	0 (0.0)	<0.1 (1)
Pancreatitis	<0.1 (3)	<0.1 (9)	<0.1 (5)	<0.1 (11)
Eczema	0.7 (77)	1.3 (139)	1.1 (129)	1.0 (131)
Hypersensitivity	3.2 (347)	4.2 (457)	3.0 (359)	2.9 (370)

Patient-year = Total patient-years of follow-up, including time through the end of study date; Events = Number of events;

Rate = Event rate per 100 patient-years ( $[(\text{Events} / \text{Patient-year}) * 100]$ )

N = Number of patients who received  $\geq 1$  dose of investigational product. Treatment groups in Extension are based on the original randomized assignments in the 20030216 study.

Multiple occurrences of the same event for a patient are counted as multiple events. Includes only treatment-emergent adverse events.

### Other Studies in Postmenopausal Women

The safety of denosumab was assessed in a 2-year, randomized, double-blind, placebo-controlled, multinational study of 332 postmenopausal women aged 43 to 83 years with low bone mass (Study 2). A total of 165 women received placebo and 164 women received denosumab administered once every 6 months as a single 60 mg SC dose. All women received calcium (at least 1000 mg) and vitamin D (at least 400 IU) supplementation per day. The incidence of adverse events was 156 (95%) in the denosumab group and 157 (95%) in the placebo group. The incidence of serious adverse events was 11% (n = 18) in the denosumab group and 6% (n = 9) in the placebo group. No subject died during the study. The 3 most common adverse events were arthralgia (26% (n = 43) denosumab vs. 26% (n = 42) placebo), nasopharyngitis (22% (n = 36) denosumab vs. 19% (n = 32) placebo), and back pain (20% (n = 33) denosumab vs. 21% (n = 34) placebo).

Two randomized, double-blind, active-controlled studies (Study 3 and Study 4) assessed the safety of denosumab compared with alendronate. In Study 3, a total of 1179 postmenopausal women with low bone mass who were treatment naive (593 randomized to denosumab 60 mg SC once every 6 months, 586 randomized to alendronate tablets 70 mg once weekly) received investigational product and were evaluated for safety. All women received daily supplemental calcium (at least 1000 mg) and vitamin D (at least 400 IU). The incidence of adverse events was 81% (n = 480) in the denosumab group and 82% (n = 482) in the alendronate group. The incidence of serious adverse events was 6% (n = 34) in the denosumab group and 6% (n = 37) in the alendronate group. One subject in each treatment group died during the study. The 3 most frequent adverse events were arthralgia (13% (n = 75) denosumab vs. 10% (n = 56) alendronate), nasopharyngitis (8% (n = 45) denosumab vs. 7% (n = 43) alendronate), and back pain (7% (n = 42) denosumab vs. 10% (n = 56) alendronate).

In Study 4, a total of 502 postmenopausal women with low bone mass who were being treated with alendronate for a median duration of 3 years (253 denosumab 60 mg SC every 6 months, 249 alendronate tablets 70 mg once weekly) received investigational product and were evaluated for safety. All women received daily supplemental calcium (at least 1000 mg) and vitamin D (at least 400 IU). The incidence of adverse events was 78% (n = 197) in the denosumab group and 79% (n = 196) in the alendronate group. The incidence of serious adverse events was 6% (n = 15) in the denosumab group and 6% (n = 16) in the alendronate group. One subject in the denosumab treatment group died during the study. The 3 most frequent adverse events were nasopharyngitis (13% (n = 34) denosumab vs. 11% (n = 27) alendronate), back pain (11% (n = 27) denosumab vs. 12% (n = 29) alendronate), and arthralgia (6% (n = 15) denosumab vs. 10% (n = 26) alendronate).

The safety profile of denosumab in women with postmenopausal osteoporosis was consistent with results in these 3 studies among women with postmenopausal bone loss. No notable differences were observed between those women who had received prior osteoporosis therapy versus those who had not received prior osteoporosis therapy (i.e., alendronate).

### **Treatment to Increase Bone Mass in Men with Osteoporosis at High Risk for Fracture**

The safety of denosumab in the treatment of men with osteoporosis was assessed in a randomized, double-blind, placebo-controlled study; a 1 year double-blind phase followed by a 1 year open-label extension.

During the double-blind phase, a total of 242 men (121 denosumab, 121 placebo) were enrolled; a total of 120 men were exposed to placebo and 120 men were exposed to denosumab administered subcutaneously once every 6 months as a single 60 mg dose. All men were instructed to take at least 1000 mg of calcium and 800 IU of vitamin D supplementation per day.

The most common adverse reactions ( $\geq 5\%$  and more common than placebo) reported in men with osteoporosis were: back pain (10 [8.3%] denosumab, 8 [6.7%] placebo), arthralgia (8 [6.7%] denosumab, 7 [5.8%] placebo), and nasopharyngitis (8 [6.7%] denosumab, 7 [5.8%] placebo).

There were 2 deaths during the clinical trial: 1 (0.8%, acute myocardial infarction) in the

denosumab group and 1 (0.8%, basilar artery thrombosis) in the placebo group.

There were 16 serious adverse events (SAEs) in 11 patients (9.2%) in the denosumab group: 6 cardiovascular (2 arterial thrombosis limb, 2 myocardial infarction, 1 peripheral ischemia, 1 vascular pseudoaneurysm), 3 prostate cancer, and one each of: chest pain, acute pancreatitis, cholecystitis, injury, post procedural complication, road traffic accident, spinal column stenosis (severity: 3 moderate, 12 severe, and 1 fatal). In the placebo group, there were 13 SAEs in 10 patients (8.3%): 3 cardiovascular (peripheral ischemia, atrial fibrillation, basilar artery thrombosis), 3 musculoskeletal (ligament rupture, meniscus lesion, osteoarthritis), 2 ophthalmic (retinal detachment, vitreous hemorrhage), and one each of: pancreatitis, pneumonia, prostatic adenoma, skull malformation, and cerebral hemorrhage (severity: 2 mild, 8 moderate, 2 severe, and 1 fatal).

The number (percentage) of patients who discontinued the investigational product or withdrew from the study due to adverse events was 4 patients (3.3%) with 4 events for the denosumab group (prostate cancer, myocardial infarction, upper respiratory tract infections, and road traffic accident), vs. 0 for the placebo group.

Adverse events reported in  $\geq 1\%$  of denosumab-treated or placebo-treated patients are shown in [Table 3](#).

**Table 3. Adverse Events Occurring in  $\geq 1\%$  of Men with Osteoporosis (First 12 Months Analysis)**

<b>SYSTEM ORGAN CLASS</b> Preferred Term	<b>denosumab</b> <b>(N = 120)</b> <b>n (%)</b>	<b>Placebo</b> <b>(N = 120)</b> <b>n (%)</b>
<b>CARDIAC DISORDERS</b>		
Angina pectoris	2 (1.7)	0 (0.0)
Arrhythmia	2 (1.7)	0 (0.0)
Atrial fibrillation	0 (0.0)	2 (1.7)
<b>EYE DISORDERS</b>		
Cataract	2 (1.7)	3 (2.5)
Conjunctivitis	0 (0.0)	2 (1.7)
<b>GASTROINTESTINAL DISORDERS</b>		
Diarrhea	2 (1.7)	3 (2.5)
Flatulence	2 (1.7)	0 (0.0)
Gastroesophageal reflux disease	1 (0.8)	2 (1.7)
Constipation	0 (0.0)	7 (5.8)
Abdominal pain upper	0 (0.0)	3 (2.5)
Dyspepsia	0 (0.0)	2 (1.7)
Gastric polyps	0 (0.0)	2 (1.7)
Inguinal hernia	0 (0.0)	2 (1.7)
<b>GENERAL DISORDERS AND ADMINISTRATION SITE CONDITIONS</b>		
Chest pain	2 (1.7)	1 (0.8)

<b>SYSTEM ORGAN CLASS</b> Preferred Term	<b>denosumab</b> <b>(N = 120)</b> n (%)	<b>Placebo</b> <b>(N = 120)</b> n (%)
Fatigue	1 (0.8)	2 (1.7)
<b>INFECTIONS AND INFESTATIONS</b>		
Nasopharyngitis	8 (6.7)	7 (5.8)
Sinusitis	2 (1.7)	1 (0.8)
Tooth infection	2 (1.7)	1 (0.8)
Upper respiratory tract infection	2 (1.7)	1 (0.8)
Influenza	1 (0.8)	4 (3.3)
Pneumonia	0 (0.0)	2 (1.7)
<b>INJURY, POISONING AND PROCEDURAL COMPLICATIONS</b>		
Fall	2 (1.7)	2 (1.7)
Contusion	2 (1.7)	0 (0.0)
Post procedural hematoma	1 (0.8)	2 (1.7)
Procedural pain	0 (0.0)	3 (2.5)
Arthropod bite	0 (0.0)	2 (1.7)
<b>INVESTIGATIONS</b>		
Weight decreased	0 (0.0)	2 (1.7)
<b>METABOLISM AND NUTRITION DISORDERS</b>		
Hypercholesterolemia	3 (2.5)	0 (0.0)
Hyperglycemia	0 (0.0)	2 (1.7)
Hyponatremia	0 (0.0)	2 (1.7)
<b>MUSCULOSKELETAL AND CONNECTIVE TISSUE DISORDERS</b>		
Back pain	10 (8.3)	8 (6.7)
Arthralgia	8 (6.7)	7 (5.8)
Osteoarthritis	4 (3.3)	2 (1.7)
Muscle spasms	3 (2.5)	0 (0.0)
Myalgia	2 (1.7)	5 (4.2)
Pain in extremity	2 (1.7)	3 (2.5)
Bone pain	2 (1.7)	0 (0.0)
Musculoskeletal pain	1 (0.8)	4 (3.3)
Musculoskeletal chest pain	1 (0.8)	2 (1.7)
Musculoskeletal stiffness	0 (0.0)	2 (1.7)
Spinal osteoarthritis	0 (0.0)	2 (1.7)
<b>NEOPLASMS BENIGN, MALIGNANT AND UNSPECIFIED (INCLUDING CYSTS AND POLYPS)</b>		
Prostate cancer <sup>a</sup>	3 (2.5)	0 (0.0)
Prostatic adenoma	1 (0.8)	2 (1.7)
<b>NERVOUS SYSTEM DISORDERS</b>		
Dizziness	2 (1.7)	2 (1.7)
Headache	1 (0.8)	5 (4.2)

<b>SYSTEM ORGAN CLASS</b> Preferred Term	<b>denosumab</b> <b>(N = 120)</b> <b>n (%)</b>	<b>Placebo</b> <b>(N = 120)</b> <b>n (%)</b>
<b>RENAL AND URINARY DISORDERS</b>		
Renal cyst	0 (0.0)	2 (1.7)
<b>RESPIRATORY, THORACIC AND MEDIASTINAL DISORDERS</b>		
Cough	1 (0.8)	3 (2.5)
Asthma	0 (0.0)	2 (1.7)
<b>SKIN AND SUBCUTANEOUS TISSUE DISORDERS</b>		
Rash	1 (0.8)	2 (1.7)
<b>VASCULAR DISORDERS</b>		
Arterial thrombosis limb	2 (1.7)	0 (0.0)
Hypertension	1 (0.8)	5 (4.2)

N = Number of subjects who received  $\geq 1$  dose of investigational

product n = Number of subjects reporting  $\geq 1$  event

Includes only treatment-emergent adverse events

<sup>a</sup> 2 of the prostate cancer cases were diagnosed within the first month of the patients receiving denosumab

### ***Osteonecrosis of the Jaw***

Osteonecrosis of the jaw (ONJ) has been reported in patients treated with denosumab or bisphosphonates, another class of anti-resorptive agents (see [7 Warnings and Precautions, Osteonecrosis of the Jaw](#)).

### ***New Malignancies***

New malignancies were reported in 4 patients (3.3%; 3 prostate cancers, 1 basal cell carcinoma) in the denosumab group and 0 in the placebo group.

### ***Cardiac Disorders***

There were 6 patients (5.0%) with cardiac AEs (2 angina pectoris, 2 myocardial infarction and 2 arrhythmia) in the denosumab group, and 3 patients (2.5%, 2 atrial fibrillation and 1 palpitations) in the placebo group. There were 2 patients (1.7%) with serious cardiac AEs (2 myocardial infarction) in the denosumab group, and 1 (0.8%, atrial fibrillation) in the placebo group.

### ***Fracture***

Clinical fractures were confirmed for 1 patient (0.8%) in the denosumab group and 2 patients (1.7%) in the placebo group; new morphometric vertebral fractures were confirmed in no patients in the denosumab group and 1 patient (0.8%) in the placebo group.

### ***Laboratory Abnormalities***

Denosumab administration was associated with decreases in serum calcium. At day 15, median change from baseline in albumin-adjusted serum calcium was -1.1% in the denosumab group and 0.0% in the placebo group. No decrease in median serum calcium was observed at months

6 and 12. No patients had Grade 3 or 4 low serum calcium values during the study.

Denosumab administration also was associated with decreases in serum phosphorus. Median change from baseline in phosphorus was (denosumab, placebo) -6.0%, 2.9% at day 15; -4.7%, 0.0% at month 6; and 0.0%, 0.0% at month 12. No patients had Grade 3 or 4 low serum phosphorus values during the study.

### Treatment to Increase Bone Mass in Patients Receiving ADT for Prostate Cancer

The safety of denosumab in the treatment of bone loss in men with nonmetastatic prostate cancer receiving ADT was assessed in a 3 year, randomized, double-blind, placebo-controlled, multinational study.

During the double-blind phase, a total of 1468 men aged 48 to 97 years were enrolled; the median age was 76 years, and 92.9% of subjects were  $\geq 65$  years of age. A total of 725 men were exposed to placebo and 731 men were exposed to denosumab administered once every 6 months as a single 60 mg subcutaneous dose. All men were instructed to take at least 1000 mg of calcium and 400 IU of vitamin D supplementation per day.

Adverse events reported in  $\geq 5\%$  of denosumab-treated patients receiving ADT for nonmetastatic prostate cancer, and more frequently than in the placebo-treated patients were (denosumab vs. placebo): arthralgia (92 [12.6%] denosumab, 80 [11.0%] placebo), back pain (81 [11.1%] denosumab, 74 [10.2%] placebo), pain in extremity (66 [9.0%] denosumab, 51 [7.0%] placebo), hypertension (57 [7.8%] denosumab, 51 [7.0%] placebo), edema peripheral (53 [7.3%] denosumab, 48 [6.6%] placebo), nasopharyngitis (47 [6.4%] denosumab, 45 [6.2%] placebo), dizziness (41 [5.6%] denosumab, 31 [4.3%] placebo), musculoskeletal pain (41 [5.6%] denosumab, 26 [3.6%] placebo), diarrhea (40 [5.5%] denosumab, 39 [5.4%] placebo), hot flush (38 [5.2%] denosumab, 32 [4.4%] placebo), and urinary tract infection (37 [5.1%] denosumab, 32 [4.4%] placebo).

The incidence of SAEs was 34.6% (n = 253) in the denosumab group and 30.6% (n = 222) in the placebo group. The 3 most common serious adverse events were myocardial infarction (14 [1.9%] denosumab, 18 [2.5%] placebo), pneumonia (11 [1.5%] denosumab, 11 [1.5%] placebo), and atrial fibrillation (11 [1.5%] denosumab, 8 [1.1%] placebo). Deaths occurred in 44 subjects (6.0%) in the denosumab group and 46 subjects (6.3%) in the placebo group.

The percentage of patients who withdrew from the study due to adverse events was 51 (7.0%) and 44 (6.1%) for the denosumab and placebo groups, respectively.

Adverse events reported in  $\geq 1\%$  of denosumab-treated or placebo-treated patients are shown in [Table 4](#).

**Table 4. Adverse Events Occurring in  $\geq 1\%$  of Men with Bone Loss Associated with ADT for Nonmetastatic Prostate Cancer**

SYSTEM ORGAN CLASS Preferred Term	denosumab (N = 731) n (%)	Placebo (N = 725) n (%)
<b>BLOOD AND LYMPHATIC SYSTEM DISORDERS</b>		

<b>SYSTEM ORGAN CLASS</b> Preferred Term	<b>denosumab</b> <b>(N = 731) n</b> <b>(%)</b>	<b>Placebo</b> <b>(N = 725) n</b> <b>(%)</b>
Anemia	33 (4.5)	35 (4.8)
<b>CARDIAC DISORDERS</b>		
Atrial fibrillation	21 (2.9)	18 (2.5)
Angina pectoris	17 (2.3)	8 (1.1)
Coronary artery disease	15 (2.1)	17 (2.3)
Myocardial infarction	14 (1.9)	18 (2.5)
Cardiac failure congestive	13 (1.8)	18 (2.5)
Bradycardia	8 (1.1)	4 (0.6)
<b>EAR AND LABYRINTH DISORDERS</b>		
Vertigo	13 (1.8)	9 (1.2)
<b>ENDOCRINE DISORDERS</b>		
Hypothyroidism	9 (1.2)	2 (0.3)
<b>EYE DISORDERS</b>		
Cataract	34 (4.7)	9 (1.2)
<b>GASTROINTESTINAL DISORDERS</b>		
Constipation	73 (10.0)	75 (10.3)
Diarrhea	40 (5.5)	39 (5.4)
Nausea	22 (3.0)	27 (3.7)
Abdominal pain	15 (2.1)	21 (2.9)
Gastroesophageal reflux disease	12 (1.6)	13 (1.8)
Gastritis	11 (1.5)	8 (1.1)
Inguinal hernia	11 (1.5)	4 (0.6)
Vomiting	11 (1.5)	17 (2.3)
Dyspepsia	10 (1.4)	13 (1.8)
Abdominal pain upper	9 (1.2)	12 (1.7)
Rectal hemorrhage	7 (1.0)	9 (1.2)
Edema peripheral	53 (7.3)	48 (6.6)
Fatigue	44 (6.0)	45 (6.2)
Asthenia	31 (4.2)	27 (3.7)
Pyrexia	11 (1.5)	10 (1.4)
Chest pain	8 (1.1)	10 (1.4)
Non-cardiac chest pain	8 (1.1)	8 (1.1)
Pain	6 (0.8)	11 (1.5)
<b>HEPATOBIILIARY DISORDERS</b>		
Cholelithiasis	7 (1.0)	12 (1.7)
<b>INFECTIONS AND INFESTATIONS</b>		
Nasopharyngitis	47 (6.4)	45 (6.2)
Urinary tract infection	37 (5.1)	32 (4.4)

<b>SYSTEM ORGAN CLASS</b> Preferred Term	<b>denosumab</b> <b>(N = 731) n</b> <b>(%)</b>	<b>Placebo</b> <b>(N = 725) n</b> <b>(%)</b>
Upper respiratory tract infection	31 (4.2)	26 (3.6)
Bronchitis	30 (4.1)	21 (2.9)
Pneumonia	29 (4.0)	25 (3.4)
Influenza	23 (3.1)	20 (2.8)
Sinusitis	17 (2.3)	15 (2.1)
Herpes zoster	11 (1.5)	7 (1.0)
Cystitis	10 (1.4)	8 (1.1)
Diverticulitis	9 (1.2)	0 (0.0)
Cellulitis	6 (0.8)	8 (1.1)
Lower respiratory tract infection	3 (0.4)	10 (1.4)
<b>INJURY, POISONING AND PROCEDURAL COMPLICATIONS</b>		
Fall	22 (3.0)	27 (3.7)
Contusion	16 (2.2)	11 (1.5)
Rib fracture	16 (2.2)	14 (1.9)
Procedural pain	15 (2.1)	3 (0.4)
Skin laceration	12 (1.6)	4 (0.6)
Muscle strain	10 (1.4)	6 (0.8)
Radius fracture	2 (0.3)	12 (1.7)
<b>INVESTIGATIONS</b>		
Weight decreased	10 (1.4)	10 (1.4)
Blood cholesterol increased	6 (0.8)	8 (1.1)
Cardiac murmur	4 (0.5)	11 (1.5)
<b>METABOLISM AND NUTRITION DISORDERS</b>		
Diabetes mellitus	14 (1.9)	18 (2.5)
Dehydration	12 (1.6)	5 (0.7)
Hypercholesterolemia	12 (1.6)	9 (1.2)
Hypokalemia	12 (1.6)	7 (1.0)
Hyperlipidemia	10 (1.4)	11 (1.5)
Gout	9 (1.2)	7 (1.0)
Anorexia	7 (1.0)	8 (1.1)
Hyperlipidemia	10 (1.4)	11 (1.5)
Gout	9 (1.2)	7 (1.0)
Anorexia	7 (1.0)	8 (1.1)
<b>MUSCULOSKELETAL AND CONNECTIVE TISSUE DISORDERS</b>		
Arthralgia	92 (12.6)	80 (11.0)
Back pain	81 (11.1)	74 (10.2)
Pain in extremity	66 (9.0)	51 (7.0)
Musculoskeletal pain	41 (5.6)	26 (3.6)

<b>SYSTEM ORGAN CLASS</b> Preferred Term	<b>denosumab</b> <b>(N = 731) n</b> <b>(%)</b>	<b>Placebo</b> <b>(N = 725) n</b> <b>(%)</b>
Osteoarthritis	31 (4.2)	23 (3.2)
Muscle spasms	18 (2.5)	17 (2.3)
Muscular weakness	15 (2.1)	13 (1.8)
Spinal osteoarthritis	14 (1.9)	5 (0.7)
Bone pain	13 (1.8)	18 (2.5)
Joint swelling	13 (1.8)	9 (1.2)
Myalgia	13 (1.8)	10 (1.4)
Arthritis	12 (1.6)	18 (2.5)
Intervertebral disc degeneration	12 (1.6)	16 (2.2)
Neck pain	12 (1.6)	11 (1.5)
Flank pain	8 (1.1)	2 (0.3)
Musculoskeletal chest pain	4 (0.5)	11 (1.5)
Musculoskeletal stiffness	3 (0.4)	8 (1.1)
<b>NEOPLASMS BENIGN, MALIGNANT AND UNSPECIFIED (INCL CYSTS AND POLYPS)</b>		
Metastases to bone	34 (4.7)	25 (3.4)
Basal cell carcinoma	13 (1.8)	7 (1.0)
<b>NERVOUS SYSTEM DISORDERS</b>		
Dizziness	41 (5.6)	31 (4.3)
Headache	22 (3.0)	27 (3.7)
Hypoesthesia	16 (2.2)	9 (1.2)
Syncope	14 (1.9)	10 (1.4)
Cerebrovascular accident	13 (1.8)	14 (1.9)
Transient ischemic attack	11 (1.5)	8 (1.1)
Sciatica	10 (1.4)	11 (1.5)
Dementia	8 (1.1)	6 (0.8)
Amnesia	7 (1.0)	8 (1.1)
<b>PSYCHIATRIC DISORDERS</b>		
Depression	35 (4.8)	28 (3.9)
Insomnia	23 (3.1)	16 (2.2)
Anxiety	11 (1.5)	11 (1.5)
Confusional state	9 (1.2)	1 (0.1)
<b>RENAL AND URINARY DISORDERS</b>		
Hematuria	23 (3.1)	25 (3.4)
Urinary retention	23 (3.1)	11 (1.5)
Dysuria	17 (2.3)	14 (1.9)
Nocturia	17 (2.3)	17 (2.3)
Pollakiuria	16 (2.2)	24 (3.3)
Urine flow decreased	11 (1.5)	4 (0.6)

<b>SYSTEM ORGAN CLASS</b> Preferred Term	<b>denosumab</b> <b>(N = 731) n</b> <b>(%)</b>	<b>Placebo</b> <b>(N = 725) n</b> <b>(%)</b>
Urinary incontinence	9 (1.2)	8 (1.1)
Micturition urgency	8 (1.1)	11 (1.5)
Renal failure	8 (1.1)	9 (1.2)
Nephrolithiasis	5 (0.7)	10 (1.4)
<b>REPRODUCTIVE SYSTEM AND BREAST DISORDERS</b>		
Gynecomastia	13 (1.8)	16 (2.2)
Erectile dysfunction	8 (1.1)	1 (0.1)
<b>RESPIRATORY, THORACIC AND MEDIASTINAL DISORDERS</b>		
Cough	33 (4.5)	27 (3.7)
Dyspnea	32 (4.4)	31 (4.3)
Chronic obstructive pulmonary disease	13 (1.8)	10 (1.4)
Pleural effusion	13 (1.8)	7 (1.0)
<b>SKIN AND SUBCUTANEOUS TISSUE DISORDERS</b>		
Rash	16 (2.2)	17 (2.3)
Pruritus	6 (0.8)	11 (1.5)
<b>VASCULAR DISORDERS</b>		
Hypertension	57 (7.8)	51 (7.0)
Hot flush	38 (5.2)	32 (4.4)
Aortic calcification	10 (1.4)	9 (1.2)
Hypotension	10 (1.4)	7 (1.0)
Aortic aneurysm	6 (0.8)	9 (1.2)

N = Number of subjects who received  $\geq 1$  dose of investigational product

n = Number of subjects reporting  $\geq 1$  event Includes only treatment-emergent adverse events

### ***New Malignancies***

Over the entire study period (double-blind and safety follow-up), the subject incidence of new primary malignancy adverse events was 7.0% in denosumab-treated patients and 5.5% in placebo-treated patients. In the open-label extension period, the subject incidence of new primary malignancy adverse events was 5.5% in the denosumab/denosumab group and 2.2% in the placebo/denosumab group.

### ***Osteonecrosis of the Jaw***

Osteonecrosis of the jaw (ONJ) has been reported in patients treated with denosumab or bisphosphonates, another class of anti-resorptive agents (see [7 Warnings and Precautions, Osteonecrosis of the Jaw](#)).

### ***Hypocalcemia***

Denosumab administration was associated with decreases in serum calcium. Hypocalcemia was reported in 1 (0.1%) subject in the denosumab group and 0 subjects in the placebo group.

**Hypersensitivity**

Adverse events potentially associated with hypersensitivity were reported in 37 (5.1%) subjects in the denosumab group and 35 (4.8%) subjects in the placebo group.

**Infections**

Infections were reported in 257 (35.2%) subjects in the denosumab group and 226 (31.2%) subjects in the placebo group. Serious adverse events of infection were reported for 43 (5.9%) denosumab subjects and 33 (4.6%) placebo subjects. A difference in the subject incidence of serious adverse events of diverticulitis was observed (5 [0.7%] denosumab vs. 0 placebo).

**Cataracts**

In denosumab-treated men with nonmetastatic prostate cancer receiving ADT, a greater incidence of cataracts was observed (34 [4.7%] denosumab, 9 [1.2%] placebo). During the 24-month safety follow-up period, cataracts were reported in 1.0% of subjects in the prior denosumab group and 1.8% of subjects in the prior placebo group.

**Atypical Femoral Fracture**

Atypical femoral fractures have been reported in patients receiving denosumab (see [7 Warnings and Precautions, Atypical Femoral Fractures](#)).

**Treatment to Increase Bone Mass in Women Receiving Adjuvant AI Therapy for Nonmetastatic Breast Cancer Who Have Low Bone Mass and are at High Risk for Fracture**

The safety of denosumab in the treatment of bone loss in women with breast cancer receiving adjuvant AI therapy was assessed in a 2 year, randomized, double-blind, placebo-controlled, multinational study.

During the double-blind phase, a total of 252 postmenopausal women aged 35 to 84 years were enrolled. A total of 120 women were exposed to placebo and 129 women were exposed to denosumab, administered once every 6 months as a single 60 mg subcutaneous dose. All women were instructed to take 1000 mg of calcium and at least 400 IU of vitamin D supplementation per day.

Adverse events reported in  $\geq 5\%$  of denosumab-treated patients receiving adjuvant AI therapy for breast cancer, and more frequently than in the placebo-treated patients were (denosumab vs. placebo): pain in extremity (19 [14.7%] vs. 14 [11.7%]), back pain (18 [14.0%] vs. 15 [12.5%]), constipation (15 [11.6%] vs. 11 [9.2%]), cough (13 [10.1%] vs. 5 [4.2%]), headache (11 [8.5%] vs. 9 [7.5%]), myalgia (11 [8.5%] vs. 5 [4.2%]), shoulder pain (11 [8.5%] vs. 4 [3.3%]), rash (10 [7.8%] vs. 6 [5.0%]), upper respiratory tract infection (10 [7.8%] vs. 6 [5.0%]), sinusitis (9 [7.0%] vs. 4 [3.3%]), vulvovaginal dryness (9 [7.0%] vs. 3 [2.5%]), anxiety (8 [6.2%] vs. 6 [5.0%]), edema peripheral (8 [6.2%] vs. 5 [4.2%]), vomiting (8 [6.2%] vs. 6 [5.0%]), dyspnea (7 [5.4%] vs. 5 [4.2%]), hypoesthesia (7 [5.4%] vs. 4 [3.3%]), muscle spasms (7 [5.4%] vs. 6 [5.0%]), Musculoskeletal chest pain (7 [5.4%] vs. 6 [5.0%]), and urinary tract infection (7 [5.4%] vs. 5 [4.2%]).

New primary malignancy was reported in 0 patients in the denosumab group and 1 patient in the placebo group (0.8%) (gastric cancer). The incidence of malignant disease progression

(breast cancer) was 3% in both treatment groups (4 subjects in the denosumab group, 4 subjects in the placebo group), with 1 death in each treatment group being attributable to underlying breast cancer. During the safety follow-up phase, new primary malignancies were reported in 1 patient in the prior denosumab group (adenocarcinoma of the pancreas) and 1 patient in the prior placebo group (multiple myeloma). Three patients (3.1%) in the prior denosumab group and 4 patients (4.4%) in the prior placebo group had an adverse event of metastasis.

A higher number of positively adjudicated fracture events was observed in patients treated with denosumab after discontinuation of treatment, compared with the 24 months treatment phase (off-treatment vs. on-treatment): osteoporotic vertebral fracture: 2 (2.1%) vs. 0; non-vertebral: 11 (11.5%) vs. 8 (6.0%). In patients treated with placebo, no increase was noted: osteoporotic vertebral fracture: 0 vs. 0; non-vertebral: 5 (5.6%) vs. 8 (6.0%).

The incidence of SAEs was 14.7% (n = 19) in the denosumab group and 9.2% (n = 11) in the placebo group. The 3 most common serious adverse events were osteoarthritis (2 [1.6%] denosumab, 0 [0.0%] placebo), myocardial infarction (1 [0.8%] denosumab, 0 [0.0%] placebo), and transient ischemic attack (1 [0.8%] denosumab, 1 [0.8%] placebo). Deaths occurred in 1 subject (0.8%) in the denosumab group and 1 subject (0.8%) in the placebo group.

The percentage of patients who withdrew from the study due to adverse events was 1 (0.8%) and 5 (4.2%) for the denosumab and placebo groups, respectively.

Adverse events reported in  $\geq 1\%$  of denosumab-treated or placebo-treated patients are shown in [Table 5](#).

**Table 5. Adverse Events Occurring in  $\geq 1\%$  of Women with Bone Loss Associated with Adjuvant AI Therapy for Breast Cancer**

<b>SYSTEM ORGAN CLASS</b> Preferred Term	<b>denosumab</b> <b>(N = 129)</b> <b>n (%)</b>	<b>Placebo (N</b> <b>= 120) n</b> <b>(%)</b>
<b>BLOOD AND LYMPHATIC SYSTEM DISORDERS</b>		
Anemia	2 (1.6)	3 (2.5)
<b>CARDIAC DISORDERS</b>		
Palpitations	2 (1.6)	2 (1.7)
Atrial fibrillation	0 (0.0)	2 (1.7)
Cardiac failure congestive	0 (0.0)	2 (1.7)
<b>EAR AND LABYRINTH DISORDERS</b>		
Tinnitus	0 (0.0)	2 (1.7)
<b>ENDOCRINE DISORDERS</b>		
Hypothyroidism	3 (2.3)	2 (1.7)
<b>EYE DISORDERS</b>		
Visual disturbance	3 (2.3)	0 (0.0)
Dry eye	2 (1.6)	0 (0.0)

<b>SYSTEM ORGAN CLASS</b> Preferred Term	<b>denosumab</b> <b>(N = 129)</b> <b>n (%)</b>	<b>Placebo (N</b> <b>= 120) n</b> <b>(%)</b>
Eye hemorrhage	0 (0.0)	2 (1.7)
<b>GASTROINTESTINAL DISORDERS</b>		
Constipation	15 (11.6)	11 (9.2)
Nausea	10 (7.8)	11 (9.2)
Vomiting	8 (6.2)	6 (5.0)
Abdominal pain	6 (4.7)	4 (3.3)
Diarrhea	5 (3.9)	9 (7.5)
Dyspepsia	4 (3.1)	5 (4.2)
Dry mouth	3 (2.3)	2 (1.7)
Hemorrhoids	3 (2.3)	2 (1.7)
Abdominal discomfort	2 (1.6)	2 (1.7)
Abdominal pain upper	2 (1.6)	1 (0.8)
Gastroesophageal reflux disease	2 (1.6)	8 (6.7)
Stomatitis	2 (1.6)	1 (0.8)
Abdominal distension	0 (0.0)	2 (1.7)
Hiatus hernia	0 (0.0)	2 (1.7)
Irritable bowel syndrome	0 (0.0)	2 (1.7)
<b>GENERAL DISORDERS AND ADMINISTRATION SITE CONDITIONS</b>		
Fatigue	17 (13.2)	17 (14.2)
Edema peripheral	8 (6.2)	5 (4.2)
Chest pain	6 (4.7)	2 (1.7)
Pain	5 (3.9)	3 (2.5)
Pyrexia	4 (3.1)	1 (0.8)
Non-cardiac chest pain	3 (2.3)	1 (0.8)
Asthenia	2 (1.6)	1 (0.8)
Axillary pain	2 (1.6)	1 (0.8)
Injection site pain	2 (1.6)	2 (1.7)
Localised edema	2 (1.6)	0 (0.0)
Pelvic mass	2 (1.6)	0 (0.0)
Malaise	1 (0.8)	3 (2.5)
<b>HEPATOBIILIARY DISORDERS</b>		
Cholelithiasis	1 (0.8)	4 (3.3)
<b>IMMUNE SYSTEM DISORDERS</b>		
Hypersensitivity	3 (2.3)	3 (2.5)
<b>INFECTIONS AND INFESTATIONS</b>		
Upper respiratory tract infection	10 (7.8)	6 (5.0)
Sinusitis	9 (7.0)	4 (3.3)
Urinary tract infection	7 (5.4)	5 (4.2)

<b>SYSTEM ORGAN CLASS</b> Preferred Term	<b>denosumab</b> <b>(N = 129)</b> <b>n (%)</b>	<b>Placebo (N</b> <b>= 120) n</b> <b>(%)</b>
Bronchitis	5 (3.9)	7 (5.8)
Herpes zoster	4 (3.1)	2 (1.7)
Influenza	4 (3.1)	5 (4.2)
Nasopharyngitis	4 (3.1)	4 (3.3)
Cellulitis	3 (2.3)	1 (0.8)
Herpes simplex	3 (2.3)	0 (0.0)
Hordeolum	3 (2.3)	0 (0.0)
Pneumonia	2 (1.6)	1 (0.8)
Tinea infection	2 (1.6)	0 (0.0)
Vaginal infection	0 (0.0)	2 (1.7)
<b>INJURY, POISONING AND PROCEDURAL COMPLICATIONS</b>		
Procedural pain	4 (3.1)	3 (2.5)
Contusion	3 (2.3)	5 (4.2)
Foot fracture	3 (2.3)	2 (1.7)
Excoriation	2 (1.6)	0 (0.0)
Fibula fracture	2 (1.6)	0 (0.0)
Joint sprain	2 (1.6)	3 (2.5)
Post-traumatic pain	2 (1.6)	0 (0.0)
Rib fracture	2 (1.6)	1 (0.8)
Fall	1 (0.8)	4 (3.3)
Meniscus lesion	1 (0.8)	2 (1.7)
Radius fracture	1 (0.8)	2 (1.7)
Incision site complication	0 (0.0)	3 (2.5)
<b>INVESTIGATIONS</b>		
Weight decreased	5 (3.9)	2 (1.7)
Blood cholesterol increased	4 (3.1)	1 (0.8)
Blood pressure increased	3 (2.3)	1 (0.8)
Weight increased	1 (0.8)	3 (2.5)
<b>METABOLISM AND NUTRITION DISORDERS</b>		
Decreased appetite	4 (3.1)	3 (2.5)
Hypercholesterolemia	3 (2.3)	1 (0.8)
Hypokalemia	3 (2.3)	2 (1.7)
Anorexia	2 (1.6)	1 (0.8)
<b>MUSCULOSKELETAL AND CONNECTIVE TISSUE DISORDERS</b>		
Arthralgia	31 (24.0)	30 (25.0)
Pain in extremity	19 (14.7)	14 (11.7)
Back pain	18 (14.0)	15 (12.5)
Myalgia	11 (8.5)	5 (4.2)

<b>SYSTEM ORGAN CLASS</b> Preferred Term	<b>denosumab</b> <b>(N = 129)</b> <b>n (%)</b>	<b>Placebo (N</b> <b>= 120) n</b> <b>(%)</b>
Shoulder pain	11 (8.5)	4 (3.3)
Muscle spasms	7 (5.4)	6 (5.0)
Musculoskeletal chest pain	7 (5.4)	6 (5.0)
Osteoarthritis	6 (4.7)	3 (2.5)
Arthritis	5 (3.9)	6 (5.0)
Bone pain	5 (3.9)	8 (6.7)
Exostosis	4 (3.1)	1 (0.8)
Musculoskeletal discomfort	4 (3.1)	1 (0.8)
Intervertebral disc protrusion	3 (2.3)	2 (1.7)
Joint swelling	3 (2.3)	3 (2.5)
Osteopenia	3 (2.3)	0 (0.0)
Bunion	2 (1.6)	0 (0.0)
Joint range of motion decreased	2 (1.6)	1 (0.8)
Muscular weakness	2 (1.6)	0 (0.0)
Neck pain	2 (1.6)	1 (0.8)
Tendonitis	2 (1.6)	3 (2.5)
Musculoskeletal pain	0 (0.0)	2 (1.7)
Musculoskeletal stiffness	0 (0.0)	2 (1.7)
<b>NEOPLASMS BENIGN, MALIGNANT AND UNSPECIFIED (INCL CYSTS AND POLYPS)</b>		
Benign breast neoplasm	5 (3.9)	1 (0.8)
Basal cell carcinoma	2 (1.6)	3 (2.5)
Breast cancer in situ	2 (1.6)	0 (0.0)
Metastases to bone	2 (1.6)	3 (2.5)
Seborrheic keratosis	2 (1.6)	0 (0.0)
Uterine leiomyoma	2 (1.6)	0 (0.0)
<b>NERVOUS SYSTEM DISORDERS</b>		
Headache	11 (8.5)	9 (7.5)
Hypoesthesia	7 (5.4)	4 (3.3)
Dizziness	5 (3.9)	4 (3.3)
Neuropathy	3 (2.3)	0 (0.0)
Tremor	3 (2.3)	0 (0.0)
Amnesia	2 (1.6)	0 (0.0)
Memory impairment	2 (1.6)	0 (0.0)
Neuropathy peripheral	2 (1.6)	1 (0.8)
Paresthesia	2 (1.6)	2 (1.7)
Neuralgia	0 (0.0)	2 (1.7)
<b>PSYCHIATRIC DISORDERS</b>		
Insomnia	12 (9.3)	14 (11.7)

<b>SYSTEM ORGAN CLASS</b> Preferred Term	<b>denosumab</b> <b>(N = 129)</b> <b>n (%)</b>	<b>Placebo (N</b> <b>= 120) n</b> <b>(%)</b>
Anxiety	8 (6.2)	6 (5.0)
Depression	7 (5.4)	11 (9.2)
Mood swings	3 (2.3)	0 (0.0)
<b>RENAL AND URINARY DISORDERS</b>		
Pollakiuria	5 (3.9)	1 (0.8)
Incontinence	3 (2.3)	0 (0.0)
Nocturia	2 (1.6)	1 (0.8)
<b>REPRODUCTIVE SYSTEM AND BREAST DISORDERS</b>		
Vulvovaginal dryness	9 (7.0)	3 (2.5)
Breast cyst	3 (2.3)	0 (0.0)
Breast pain	3 (2.3)	6 (5.0)
Vaginal hemorrhage	3 (2.3)	1 (0.8)
Breast tenderness	2 (1.6)	1 (0.8)
Breast induration	0 (0.0)	2 (1.7)
<b>RESPIRATORY, THORACIC AND MEDIASTINAL DISORDERS</b>		
Cough	13 (10.1)	5 (4.2)
Dyspnea	7 (5.4)	5 (4.2)
Pharyngolaryngeal pain	5 (3.9)	1 (0.8)
Nasal congestion	3 (2.3)	0 (0.0)
Respiratory tract congestion	2 (1.6)	1 (0.8)
Rhinorrhea	2 (1.6)	0 (0.0)
Rhinitis allergic	1 (0.8)	2 (1.7)
Sinus congestion	1 (0.8)	2 (1.7)
Chronic obstructive pulmonary disease	0 (0.0)	2 (1.7)
Epistaxis	0 (0.0)	2 (1.7)
Pneumonitis	0 (0.0)	2 (1.7)
<b>SKIN AND SUBCUTANEOUS TISSUE DISORDERS</b>		
Rash	10 (7.8)	6 (5.0)
Alopecia	5 (3.9)	2 (1.7)
Night sweats	3 (2.3)	0 (0.0)
Dry skin	2 (1.6)	1 (0.8)
Erythema	2 (1.6)	2 (1.7)
Skin lesion	2 (1.6)	1 (0.8)
Dermatitis	1 (0.8)	2 (1.7)
Hyperhidrosis	1 (0.8)	2 (1.7)
Dermatitis contact	0 (0.0)	2 (1.7)
Nail disorder	0 (0.0)	3 (2.5)
<b>VASCULAR DISORDERS</b>		

<b>SYSTEM ORGAN CLASS</b> Preferred Term	<b>denosumab</b> <b>(N = 129)</b> <b>n (%)</b>	<b>Placebo (N</b> <b>= 120) n</b> <b>(%)</b>
Hot flush	7 (5.4)	8 (6.7)
Lymphoedema	4 (3.1)	4 (3.3)
Hypertension	2 (1.6)	7 (5.8)

N = Number of subjects who received  $\geq 1$  dose of investigational product

n = Number of subjects reporting  $\geq 1$  event Includes only treatment-emergent adverse events

### **Treatment and Prevention of Glucocorticoid-Induced Osteoporosis in Women and Men at High Risk for Fracture**

The safety of denosumab in the treatment of glucocorticoid-induced osteoporosis was demonstrated in a 1-year, randomized, multicentre, double-blind, double-dummy, parallel-group, active-controlled study of 795 patients (70% women and 30% men) aged 20 to 94 years (mean age of 63.1 years) treated with  $\geq 7.5$  mg daily oral prednisone (or equivalent) at high risk for fracture.

Two subpopulations were studied: glucocorticoid-continuing ( $\geq 7.5$  mg daily prednisone or its equivalent for  $\geq 3$  months prior to study enrollment and planning to continue treatment for a total of at least 6 months; n = 505) and glucocorticoid-initiating ( $\geq 7.5$  mg daily prednisone or its equivalent for  $< 3$  months prior to study enrollment and planning to continue treatment for a total of at least 6 months; n = 290).

A total of 394 patients were exposed to denosumab, administered once every 6 months as a single 60 mg subcutaneous injection. A total of 384 patients were exposed to risedronate, administered orally at a dose of 5 mg once daily (active control). All patients were instructed to take at least 1000 mg calcium and 800 IU vitamin D supplementation daily.

The most common adverse events reported with denosumab were musculoskeletal pain (denosumab 54 [13.7%] versus risedronate 56 [14.6%]), upper respiratory tract infections (denosumab 45 [11.4%] versus risedronate 48 [12.5%]) and urinary tract infections (denosumab 21 [5.3%] versus risedronate 20 [5.2%]).

Sixty-three (63) serious adverse events (SAEs) were reported in the denosumab group (16.0%) and 65 reported in the risedronate group (16.9%). The most frequent SAEs reported in  $\geq 0.5\%$  of patients in the denosumab group were pneumonia (1.3%, n = 5), cardiac failure (0.8%, n = 3), and transient ischemic attack (0.8%, n = 3). In the risedronate group, the most frequent SAEs reported were pneumonia (1.6%, n = 6), osteoarthritis (1.0%, n = 4), pulmonary embolism (1.0%, n = 4), and back pain (0.8%, n = 3). Eight (8) deaths were reported: 6 patients (1.5%) in the denosumab group and 2 patients (0.5%) in the risedronate group. In the denosumab group, the fatal adverse events (1 patient each) were alveolitis allergic, cardiopulmonary failure, cerebral ischemia, cerebrovascular accident, neoplasm, and organizing pneumonia.

The percentage of patients who withdrew from the study due to adverse events was 3.8% (n = 15) in the denosumab group and 3.6% (n = 14) in the risedronate group.

Adverse events reported in  $\geq 1\%$  of denosumab-treated or risedronate-treated patients by system organ class and medical concept groups / preferred term are shown in [Table 6](#).

**Table 6. Adverse Events Occurring in  $\geq 1\%$  of Patients With Glucocorticoid-Induced Osteoporosis at High Risk for Fracture**

<b>SYSTEM ORGAN CLASS</b> Medical Concept Group <sup>a</sup> / Preferred Term <sup>b</sup>	<b>denosumab</b> <b>60 mg Q6M</b> <b>(N = 394) n</b> <b>(%)</b>	<b>Risedronate 5</b> <b>mg QD</b> <b>(N = 384) n</b> <b>(%)</b>
<b>BLOOD AND LYMPHATIC SYSTEM DISORDERS</b>		
Anemia <sup>1a</sup>	15 (3.8)	15 (3.9)
<b>CARDIAC DISORDERS</b>		
Cardiac arrhythmias <sup>2</sup>	7 (1.8)	6 (1.6)
Coronary artery disorders <sup>3</sup>	4 (1.0)	5 (1.3)
Cardiac failure <sup>4</sup>	4 (1.0)	2 (0.5)
<b>EAR AND LABYRINTH DISORDERS</b>		
Vertigo	4 (1.0)	4 (1.0)
<b>EYE DISORDERS</b>		
Cataract	5 (1.3)	15 (3.9)
Glaucoma <sup>5</sup>	2 (0.5)	4 (1.0)
<b>GASTROINTESTINAL DISORDERS</b>		
Abdominal pain <sup>6</sup>	20 (5.1)	13 (3.4)
Dyspepsia	12 (3.0)	10 (2.6)
Diarrhea	11 (2.8)	13 (3.4)
Constipation	11 (2.8)	6 (1.6)
Vomiting	10 (2.5)	6 (1.6)
Nausea	9 (2.3)	14 (3.6)
Gastritis <sup>7</sup>	4 (1.0)	5 (1.3)
Hemorrhoids <sup>8</sup>	4 (1.0)	3 (0.8)
Abdominal distension	4 (1.0)	1 (0.3)
Hernias <sup>9</sup>	3 (0.8)	4 (1.0)
Gastroesophageal reflux disease	2 (0.5)	6 (1.6)
Colitis <sup>10</sup>	0 (0.0)	4 (1.0)
<b>GENERAL DISORDERS AND ADMINISTRATION SITE CONDITIONS</b>		
Fatigue	6 (1.5)	5 (1.3)
Asthenia	6 (1.5)	2 (0.5)
Pyrexia	4 (1.0)	4 (1.0)
Edema peripheral	4 (1.0)	2 (0.5)
Peripheral swelling	2 (0.5)	4 (1.0)

**Table 6. Adverse Events Occurring in ≥ 1% of Patients With Glucocorticoid-Induced Osteoporosis at High Risk for Fracture**

<b>SYSTEM ORGAN CLASS</b> Medical Concept Group <sup>a</sup> /Preferred Term <sup>b</sup>	<b>denosumab</b> <b>60 mg Q6M</b> <b>(N = 394) n</b> <b>(%)</b>	<b>Risedronate 5</b> <b>mg QD</b> <b>(N = 384) n</b> <b>(%)</b>
<b>INFECTIONS AND INFESTATIONS</b>		
Upper respiratory tract infections <sup>11</sup>	45 (11.4)	48 (12.5)
Urinary tract infections <sup>12a</sup>	21 (5.3)	20 (5.2)
Bronchitis <sup>13</sup>	16 (4.1)	12 (3.1)
Gastrointestinal infections <sup>14</sup>	15 (3.8)	10 (2.6)
Oral infections <sup>15</sup>	9 (2.3)	7 (1.8)
Pneumonia <sup>16</sup>	8 (2.0)	9 (2.3)
Respiratory tract infection	6 (1.5)	5 (1.3)
Herpes infection <sup>17</sup>	2 (0.5)	7 (1.8)
<b>INJURY, POISONING AND PROCEDURAL COMPLICATIONS</b>		
Non-vertebral fractures <sup>18</sup>	20 (5.1)	14 (3.6)
Vertebral fracture <sup>19</sup>	8 (2.0)	9 (2.3)
Fall	8 (2.0)	7 (1.8)
Procedural pain	1 (0.3)	4 (1.0)
<b>INVESTIGATIONS</b>		
Weight decreased	1 (0.3)	4 (1.0)
<b>METABOLISM AND NUTRITION DISORDERS</b>		
Diabetes mellitus <sup>20</sup>	8 (2.0)	3 (0.8)
Hyperglycemia	4 (1.0)	6 (1.6)
Hypercholesterolemia <sup>21a</sup>	2 (0.5)	5 (1.3)
<b>MUSCULOSKELETAL AND CONNECTIVE TISSUE DISORDERS</b>		
Musculoskeletal pain <sup>22a</sup>	54 (13.7)	56 (14.6)
Osteoarthritis	8 (2.0)	13 (3.4)
Polymyalgia rheumatica	8 (2.0)	1 (0.3)
Rheumatoid arthritis	5 (1.3)	10 (2.6)
Muscle spasms	5 (1.3)	3 (0.8)
<b>NERVOUS SYSTEM DISORDERS</b>		
Headaches <sup>23</sup>	15 (3.8)	10 (2.6)
Dizziness	9 (2.3)	8 (2.1)
Paresthesia	4 (1.0)	3 (0.8)
<b>PSYCHIATRIC DISORDERS</b>		
Insomnia	3 (0.8)	5 (1.3)

**Table 6. Adverse Events Occurring in  $\geq 1\%$  of Patients With Glucocorticoid-Induced Osteoporosis at High Risk for Fracture**

<b>SYSTEM ORGAN CLASS</b> Medical Concept Group <sup>a</sup> /Preferred Term <sup>b</sup>	<b>denosumab</b> <b>60 mg Q6M</b> <b>(N = 394) n</b> <b>(%)</b>	<b>Risedronate 5</b> <b>mg QD</b> <b>(N = 384) n</b> <b>(%)</b>
<b>RENAL AND URINARY DISORDERS</b>		
Renal impairment/ failure <sup>24</sup>	3 (0.8)	10 (2.6)
<b>RESPIRATORY, THORACIC AND MEDIASTINAL DISORDERS</b>		
Cough	6 (1.5)	7 (1.8)
Dyspnea	5 (1.3)	6 (1.6)
Epistaxis	4 (1.0)	0 (0.0)
Asthma	1 (0.3)	8 (2.1)
Pulmonary embolism	0 (0.0)	4 (1.0)
<b>SKIN AND SUBCUTANEOUS TISSUE DISORDERS</b>		
Rash <sup>25</sup>	4 (1.0)	4 (1.0)
Dermatitis and eczema <sup>26</sup>	4 (1.0)	1 (0.3)
Alopecia	3 (0.8)	5 (1.3)
<b>SURGICAL AND MEDICAL PROCEDURES</b>		
Tooth extraction	1 (0.3)	6 (1.6)
<b>VASCULAR DISORDERS</b>		
Hypertension <sup>27</sup>	16 (4.1)	13 (3.4)

N = Number of subjects who received  $\geq 1$  dose of investigational product Q6M = Every 6 months; QD = Every day  
The cut-off of  $\geq 1\%$  applies to the subject incidence rate of medical concept groups or preferred terms.

a Medical concept group is placed in the most clinically relevant system organ class (SOC) but contains preferred terms from more than one SOC.

b Preferred terms are listed within medical concept groups in order of frequency reported with respect to denosumab.

**Medical concept groups** were identified as following:

- <sup>1</sup>Anemia, Iron deficiency anemia, Hypochromic anemia, Microcytic anemia, Hemoglobin decreased
- <sup>2</sup>Atrial fibrillation, Tachycardia, Supraventricular extrasystoles, Supraventricular tachycardia, Ventricular tachycardia, Arrhythmia, Cardio-respiratory arrest, Defect conduction intraventricular
- <sup>3</sup>Angina pectoris, Coronary artery disease, Myocardial ischemia, Acute myocardial infarction, Myocardial infarction
- <sup>4</sup>Cardiac failure, Cardiac failure congestive
- <sup>5</sup>Glaucoma, Angle closure glaucoma
- <sup>6</sup>Abdominal pain upper, Abdominal pain, Abdominal pain lower, Gastrointestinal pain
- <sup>7</sup>Gastritis, Chronic gastritis, Gastritis erosive, Reflux gastritis
- <sup>8</sup>Hemorrhoids, Hemorrhoidal hemorrhage

- <sup>9</sup>Hiatus hernia, Inguinal hernia, Inguinal hernia strangulated
- <sup>10</sup>Colitis, Colitis ulcerative
- <sup>11</sup>Nasopharyngitis, Upper respiratory tract infection, Influenza, Sinusitis, Pharyngitis, Tonsillitis, Rhinitis, Viral pharyngitis, Viral upper respiratory tract infection, Acute sinusitis, Laryngitis, Peritonsillar abscess, Sinusitis bacterial
- <sup>12</sup>Urinary tract infection, Cystitis, Urinary tract infection bacterial, Pyelonephritis, Pyelonephritis acute, Cystitis escherichia, Urogenital infection bacterial, Cystitis interstitial, Urinary tract infection viral
- <sup>13</sup>Bronchitis, Bronchitis viral, Bronchitis bacterial
- <sup>14</sup>Gastroenteritis, Diverticulitis, Gastroenteritis viral, Helicobacter gastritis, Gastrointestinal infection, Abdominal abscess, Clostridium colitis, Clostridium difficile colitis
- <sup>15</sup>Gingivitis, Tooth infection, Periodontitis, Pulpitis dental, Oral candidiasis, Oral infection, Tooth abscess
- <sup>16</sup>Pneumonia, Pneumonia bacterial
- <sup>17</sup>Genital herpes simplex, Herpes simplex, Herpes zoster, Herpes virus infection, Herpes zoster cutaneous disseminated
- <sup>18</sup>Rib fracture, Foot fracture, Humerus fracture, Pubis fracture, Femur fracture, Hand fracture, Radius fracture, Acetabulum fracture, Fibula fracture, Skull fracture, Femoral neck fracture, Patella fracture
- <sup>19</sup>Thoracic vertebral fracture, Lumbar vertebral fracture, Fractured sacrum
- <sup>20</sup>Diabetes mellitus, Type 2 diabetes mellitus
- <sup>21</sup>Hypercholesterolemia, Blood cholesterol increased
- <sup>22</sup>Back pain, Arthralgia, Pain in extremity, Bone pain, Myalgia, Musculoskeletal pain, Spinal pain, Neck pain, Musculoskeletal chest pain, Non-cardiac chest pain, Pain in jaw, Fibromyalgia, Flank pain, Limb discomfort, Musculoskeletal discomfort
- <sup>23</sup>Headache, Migraine, Migraine with aura, Sinus headache
- <sup>24</sup>Renal impairment, Renal failure, Acute kidney injury, Chronic kidney disease
- <sup>25</sup>Rash, Rash generalised, Rash vesicular
- <sup>26</sup>Seborrhoeic dermatitis, Dermatitis atopic, Eczema, Intertrigo
- <sup>27</sup>Hypertension, Diastolic hypertension

### ***New Malignancies***

The subject incidence of new primary malignancy adverse events at 12 months was 5 (1.3%) in the denosumab group and 3 (0.8%) in the risedronate group.

### ***Osteonecrosis of the Jaw***

No cases of osteonecrosis of the jaw (ONJ) were reported.

### ***Hypocalcemia***

Denosumab administration was associated with decreases in serum calcium. Hypocalcemia was reported in 1 (0.3%) patient in the denosumab group and 0 patients in the risedronate group.

### ***Hypersensitivity***

Adverse events potentially associated with hypersensitivity were reported in 19 (4.8%) patients in the denosumab group and 12 (3.1%) patients in the risedronate group.

**Infections**

Infections were reported in 105 (26.6%) patients in the denosumab group and 111 (28.9%) patients in the risedronate group. Serious adverse events of infection were reported for 17 (4.3%) denosumab patients and 15 (3.9%) risedronate patients. The most commonly reported serious infection was pneumonia in both groups (denosumab [1.3%, n = 5]; risedronate [1.6%, n = 6]).

**Atypical Femoral Fracture**

Atypical femoral fracture (AFF) was reported in 1 (0.3%) patient in the denosumab group and 0 patients in the risedronate group.

**Fracture**

The subject incidence of clinical fractures was 4.8% (n = 19) in the denosumab group and 3.8% (n = 15) in the risedronate group. The subject incidence of new vertebral fractures was 2.7% (n = 9) in the denosumab group and 3.2% (n = 11) in the risedronate group.

**8.3 Less Common Clinical Trial Adverse Reactions (< 1%)**

Postmenopausal Osteoporosis\*

**MUSCULOSKELETAL AND CONNECTIVE TISSUE DISORDERS:** Arthralgia, Muscle spasms, Pain in extremity, Bone pain, Myalgia, Musculoskeletal stiffness, Musculoskeletal pain, Osteoarthritis, Neck pain, Exostosis, Joint swelling, Muscle fatigue, Limb discomfort, Tendonitis, Joint stiffness, Muscular weakness, Nodule on extremity, Fistula, Groin pain, Joint ankylosis, Limb deformity, Muscle hemorrhage, Rheumatoid arthritis, Spinal deformity, Spondylitis, Polymyalgia rheumatica, Sensation of heaviness, Arthritis, Bone callus excessive, Foot deformity, Muscle atrophy, Osteitis, Renal rickets, Resorption bone increased, Synovitis, Tendon pain, Tenosynovitis

**GASTROINTESTINAL DISORDERS:** Nausea, Constipation, Diarrhea, Vomiting, Abdominal pain, Flatulence, Abdominal pain upper, Dry mouth, Gastritis, Dyspepsia, Stomach discomfort, Abdominal distension, Abdominal discomfort, Abdominal pain lower, Celiac disease, Fecalith, Frequent bowel movements, Gastric ulcer, Gastritis erosive, Gastroesophageal reflux disease, Gingivitis, Glossodynia, Hemorrhoids, Irritable bowel syndrome, Oral cavity fistula, Pancreatitis, Pancreatitis acute, Rectal hemorrhage, Aphthous stomatitis, Change of bowel habit, Enterocolitis, Gastroduodenitis, Gastrointestinal hemorrhage, Lip swelling, Melena, Esophageal spasm, Rectal prolapse, Reflux Esophagitis, Tongue ulceration

**INFECTIONS AND INFESTATIONS:** Nasopharyngitis, Respiratory tract infection, Upper respiratory tract infection, Influenza, Urinary tract infection, Rhinitis, Lower respiratory tract infection, Pneumonia, Bronchitis, Cystitis, Sinusitis, Herpes zoster, Oral herpes, Pharyngitis, Herpes virus infection, Tinea pedis, Viral infection, Chlamydial infection, Eczema infected, Gastroenteritis viral, Herpes ophthalmic, Laryngitis, Liver abscess, Lung infection, Viremia, Borrelia infection, Chronic sinusitis, Diverticulitis, Furuncle, Genital infection fungal, Gingival infection, Hematoma infection, Helicobacter infection, Herpes simplex, Sialoadenitis, Tracheitis

**NERVOUS SYSTEM DISORDERS:** Headache, Dizziness, Paresthesia, Lethargy, Somnolence,

Hypoesthesia, Ischemic stroke, Dysgeusia, Sciatica, Tremor, Parosmia, Syncope, Transient ischemic attack, Disturbance in attention, Epilepsy, Freezing phenomenon, Global amnesia, Guillain-Barre syndrome, Head discomfort, Hemicephalgia, Hypotonia, Poor quality sleep, Trigeminal neuralgia, Hypersomnia, Loss of consciousness, Memory impairment, Ageusia, Amnesia, Anosmia, Dyskinesia, Formication, Intercostal neuralgia, Migraine, Muscle contractions involuntary, Neuritis cranial, Parkinson's disease, Parkinsonism, Restless legs syndrome

**GENERAL DISORDERS AND ADMINISTRATION SITE CONDITIONS:** Asthenia, Fatigue, Injection site pain, Edema peripheral, Injection site erythema, Pain, Influenza like illness, Injection site irritation, Feeling hot, Malaise, Injection site bruising, Injection site reaction, Injection site hematoma, Injection site rash, Pyrexia, Noncardiac chest pain, Peripheral coldness, Chills, Injection site warmth, Chest discomfort, Feeling cold, Gait disturbance, Hernia, Impaired healing, Injection site discomfort, Injection site mass, Injection site swelling, Irritability, Injection site pruritus, Fat tissue increased, Injection site scab, Thirst

**SKIN AND SUBCUTANEOUS TISSUE DISORDERS:** Pruritus, Rash, Alopecia, Hyperhidrosis, Eczema, Dermatitis allergic, Erythema, Dry skin, Rash macular, Rash pruritic, Onychomadesis, Ecchymosis, Pruritus generalised, Dermatitis, Rosacea, Subcutaneous nodule, Blister, Dermatitis atopic, Hair growth abnormal, Heat rash, Hyperkeratosis, Lichen planus, Nail disorder, Psoriasis, Rash generalised, Skin exfoliation, Skin warm, Urticaria, Acne, Night sweats, Pigmentation disorder, Purpura, Rash maculo-papular, Skin lesion, Skin nodule, Skin wrinkling, Swelling face, Vasculitic rash

**VASCULAR DISORDERS:** Hypertension, Hot flush, Aortic calcification, Deep vein thrombosis, Flushing, Hematoma, Varicose vein, Arteriosclerosis, Aortic stenosis, Orthostatic hypotension, Peripheral ischemia, Vasculitis, Hypotension, Thrombophlebitis, Hypertensive crisis, Venous thrombosis

**RESPIRATORY, THORACIC AND MEDIASTINAL DISORDERS:** Cough, Pharyngolaryngeal pain, Dyspnea, Dysphonia, Nasal congestion, Epistaxis, Rhinorrhea, Pulmonary embolism, Asthma, Dyspnea exertional, Nocturnal dyspnea, Sinus congestion, Sneezing, Vasomotor rhinitis, Acute pulmonary edema, Nasal dryness, Pleurisy, Productive cough, Rhinitis allergic

**CARDIAC DISORDERS:** Palpitations, Angina pectoris, Cardiac failure, Arrhythmia, Acute myocardial infarction, Extrasystoles, Ventricular extrasystoles, Atrial fibrillation, Myocardial infarction, Cardiac failure chronic, Coronary artery disease, Hypertensive cardiomyopathy, Ischemic cardiomyopathy, Supraventricular extrasystoles, Tachycardia, Mitral valve incompetence, Tachyarrhythmia

**EYE DISORDERS:** Cataract, Glaucoma, Conjunctivitis allergic, Dry eye, Ocular discomfort, Eyelid pain, Lacrimation increased, Visual disturbance, Vitreous disorder, Conjunctivitis, Eye pain, Arteriosclerotic retinopathy, Blepharitis, Blepharospasm, Eyelids pruritus, Lacrimal gland enlargement, Photophobia, Vision blurred, Vitreous hemorrhage

**EAR AND LABYRINTH DISORDERS:** Vertigo, Ear pain, Ear discomfort, Tinnitus, Cerumen impaction, Ear congestion, Ear disorder, Otosalpingitis, Tympanic membrane perforation

**NEOPLASMS BENIGN, MALIGNANT AND UNSPECIFIED (INCL CYSTS AND POLYPS):**

Breast cancer, Ovarian cancer, Basal cell carcinoma, Benign neoplasm of thyroid gland, Benign soft tissue neoplasm, Cerebellar tumour, Cervix carcinoma, Lipoma, Multiple myeloma, Uterine leiomyoma, Benign breast neoplasm, Acral lentiginous melanoma stage unspecified, Adenocarcinoma, Benign bone neoplasm, Benign neoplasm, Bladder neoplasm, Colon cancer, Diffuse large B-cell lymphoma recurrent, Hemangioma, Hemangioma of liver, Lipoma of breast, Melanocytic nevus

**BLOOD AND LYMPHATIC SYSTEM DISORDERS:** Eosinophilia, Leukopenia, Thrombocytopenia, Anemia, Leukocytosis, Lymphadenopathy, Lymphocytosis, Neutrophilia, Pancytopenia, Neutropenia, Bone marrow failure, Lymphopenia

**INVESTIGATIONS:** Weight decreased, Blood pressure increased, Alanine aminotransferase increased, Coagulation time shortened, Red blood cell sedimentation rate increased, Blood chloride decreased, Blood sodium decreased, Weight increased, Cardiac murmur, Aspartate aminotransferase increased, Hemoglobin decreased, International normalised ratio increased, Platelet count decreased, Red blood cell count decreased, Rheumatoid factor positive

**METABOLISM AND NUTRITION DISORDERS:** Hypercalcemia, Anorexia, Hypercholesterolemia, Decreased appetite, Diabetes mellitus, Glucose tolerance impaired, Hypomagnesemia

**PSYCHIATRIC DISORDERS:** Depression, Depressed mood, Insomnia, Apathy, Dysthymic disorder, Sleep disorder, Restlessness

**RENAL AND URINARY DISORDERS:** Dysuria, Hematuria, Nephrolithiasis, Acute prerenal failure, Polyuria, Urge incontinence, Urine abnormality, Pollakiuria, Nephrosclerosis, Nocturia, Proteinuria, Renal impairment, Urine odour abnormal

**REPRODUCTIVE SYSTEM AND BREAST DISORDERS:** Breast pain, Vulvovaginal pruritus, Breast disorder, Vaginal hemorrhage, Breast discomfort, Vulvovaginal dryness, Breast mass, Fibrocystic breast disease, Breast necrosis, Breast tenderness, Vulvovaginal burning sensation

**ENDOCRINE DISORDERS:** Goitre, Hyperthyroidism, Hypothyroidism, Hyperparathyroidism

**INJURY, POISONING AND PROCEDURAL COMPLICATIONS:** Thoracic vertebral fracture, Clavicle fracture, Femoral neck fracture, Post procedural hemorrhage, Lumbar vertebral fracture, Fall, Anastomotic ulcer hemorrhage, Contusion, Humerus fracture, Ilium fracture, Joint dislocation, Joint sprain, Post concussion syndrome, Radius fracture, Scratch

**HEPATOBIILIARY DISORDERS:** Liver disorder, Hepatic cyst, Cholecystitis, Cholelithiasis

**IMMUNE SYSTEM DISORDERS:** Hypersensitivity, Drug hypersensitivity

**CONGENITAL, FAMILIAL AND GENETIC DISORDERS:** Familial tremor

**SURGICAL AND MEDICAL PROCEDURES:** Fistula repair

*\*Terms designated by investigators as related to study drugs*

**Glucocorticoid-Induced Osteoporosis\***

**BLOOD AND LYMPHATIC SYSTEM DISORDERS:** Leukopenia, Immune thrombocytopenic

purpura, Thrombocytopenia

**CARDIAC DISORDERS:** Mitral valve incompetence, Tricuspid valve incompetence, Palpitations

**ENDOCRINE DISORDERS:** Hypothyroidism

**EYE DISORDERS:** Visual acuity reduced

**GASTROINTESTINAL DISORDERS:** Abdominal discomfort, Gastrointestinal disorder, Flatulence

**GENERAL DISORDERS AND ADMINISTRATION SITE CONDITIONS:** Chest pain, Influenza like illness, Malaise

**HEPATOBIILIARY DISORDERS:** Liver disorder

**INFECTIONS AND INFESTATIONS:** Erysipelas, Onychomycosis

**INJURY, POISONING AND PROCEDURAL COMPLICATIONS:** Contusion, Meniscus injury, Joint injury, Tooth avulsion

**INVESTIGATIONS:** Alanine aminotransferase increased, Weight increased, Aspartate aminotransferase increased, Blood glucose increased

**METABOLISM AND NUTRITION DISORDERS:** Dyslipidemia, Decreased appetite, Dehydration, Hypokalemia

**MUSCULOSKELETAL AND CONNECTIVE TISSUE DISORDERS:** Bursitis, Arthritis, Muscular weakness, Synovial cyst, Synovitis, Joint swelling, Vertebral foraminal stenosis

**NERVOUS SYSTEM DISORDERS:** Transient ischemic attack, Sciatica, Carpal tunnel syndrome, Cerebrovascular accident, Tremor

**RENAL AND URINARY DISORDERS:** Urinary incontinence

**REPRODUCTIVE SYSTEM AND BREAST DISORDERS:** Ovarian cyst, Benign prostatic hyperplasia

**RESPIRATORY, THORACIC AND MEDIASTINAL DISORDERS:** Chronic obstructive pulmonary disease, Dyspnea exertional, Sinus congestion

**SKIN AND SUBCUTANEOUS TISSUE DISORDERS:** Pruritus generalized, Swelling face, Acne, Erythema, Rosacea, Skin disorder

**SURGICAL AND MEDICAL PROCEDURES:** Knee arthroplasty

**VASCULAR DISORDERS:** Hematoma, Hot flush

\*reported by < 1% and  $\geq$  0.5% (n = 2) of denosumab-treated patients

#### **8.4 Abnormal Laboratory Findings: Hematologic, Clinical Chemistry and Other Quantitative Data**

Not applicable

#### **8.5 Post-Market Adverse Reactions**

##### **Hypersensitivity Reactions**

Hypersensitivity reactions including rash, urticaria, facial swelling, erythema, and anaphylactic reactions have been reported in patients receiving denosumab.

### **Hypersensitivity Vasculitis**

Hypersensitivity vasculitis has been reported in patients receiving denosumab.

### **Drug Reaction with Eosinophilia and Systemic Symptoms**

Drug reaction with eosinophilia and systemic symptoms (DRESS) syndrome has been reported in patients receiving denosumab.

### **Lichenoid Drug Eruptions**

In the postmarketing experience, lichenoid drug eruptions (eg, lichen planus-like reactions) have been observed.

### **Severe Hypocalcemia**

Symptoms of hypocalcemia in denosumab clinical studies include paresthesias or muscle stiffness, twitching, spasms and muscle cramps. In the postmarket setting, severe symptomatic hypocalcemia has been reported in those receiving denosumab and who are at increased risk of hypocalcemia, particularly in patients with severe renal impairment, receiving dialysis or treatment with other calcium lowering drugs. In some cases this has resulted in hospitalization, life-threatening events, and fatal cases. Most cases of hypocalcemia occur within the first few weeks of initiating therapy. Symptoms of severe hypocalcemia may include QT interval prolongation, tetany and convulsions and altered mental status. Healthcare Professionals should follow standard medical care guidelines for the treatment of signs and symptoms associated with severe hypocalcemia. See [7 Warnings and Precautions, Endocrine and Metabolism, Hypocalcemia](#) for further information on monitoring hypocalcemia.

### **Musculoskeletal Pain**

Musculoskeletal pain, including severe cases, has been reported in patients receiving denosumab.

### **Osteonecrosis of the Jaw (ONJ)**

Osteonecrosis of the jaw has been reported in patients receiving denosumab.

### **Alopecia**

In the postmarketing experience, alopecia has been observed.

## **9 Drug Interactions**

### **9.2 Drug Interactions Overview**

In subjects with postmenopausal osteoporosis, denosumab (60 mg SC) did not affect the pharmacokinetics of midazolam, which is metabolized by cytochrome P450 3A4 (CYP3A4), indicating that denosumab is not expected to affect the pharmacokinetics of drugs metabolized by this enzyme in this population (see [10 Clinical Pharmacology, Pharmacokinetics](#)).

The pharmacokinetics and pharmacodynamics of denosumab were similar in postmenopausal

women with osteoporosis transitioning from alendronate therapy compared to those who had not received prior alendronate therapy.

### **9.3 Drug-Behaviour Interactions**

Interactions with behaviour have not been established.

### **9.4 Drug-Drug Interactions**

Interactions with other drugs have not been established.

### **9.5 Drug-Food Interactions**

Interactions with food have not been established.

### **9.6 Drug-Herb Interactions**

Interactions with herbal products have not been established.

### **9.7 Drug-Laboratory Test Interactions**

Interactions with laboratory tests have not been established.

## **10 Clinical Pharmacology**

### **10.1 Mechanism of Action**

Denosumab (denosumab) is a human IgG2 monoclonal antibody with affinity and specificity for human RANK ligand (RANKL). RANKL exists as a transmembrane or soluble protein. RANK ligand is essential for the formation, function and survival of osteoclasts, the sole cell type responsible for bone resorption. Osteoclasts play an important role in bone loss associated with osteoporosis and hormone ablation. Denosumab targets and binds with high affinity and specificity to RANKL, preventing RANKL from activating its only receptor, RANK, on the surface of osteoclasts and their precursors, independent of bone surface. Prevention of RANKL-RANK interaction inhibits osteoclast formation, function and survival, thereby decreasing bone resorption and increasing bone mass and strength in both cortical and trabecular bone throughout the skeleton.

### **Animal Pharmacology**

The single- and multiple-dose pharmacokinetics of denosumab following intravenous or subcutaneous administration of denosumab were evaluated in mice, rats, and cynomolgus monkeys. Serum concentrations of denosumab were determined using a conventional sandwich enzyme-linked immunosorbent assay (ELISA) with a limit of quantification (LOQ) ranging from 0.78 to 5 ng/mL. In addition, tissue distribution (by liquid scintillation counting) and quantitative whole body autoradiography studies were conducted in cynomolgus monkeys following a single SC dose.

In mice and rats, species in which denosumab does not bind RANKL, the intravenous pharmacokinetics of denosumab were linear over the dose range of approximately

0.1 to 10 mg/kg, with low clearance and a volume of distribution at steady-state ( $V_{ss}$ ) that indicated a lack of extensive extravascular distribution. After a single SC dose (1 mg/kg), maximum serum denosumab concentrations ( $C_{max}$ ) occurred at 72 hours postdose in both species, and bioavailability was 86% in mice and 56% in rats.

Approximately 6- and 15-fold higher clearance was observed in huRANKL and knock-out mice lacking expression of the Fc neonatal receptor (FcRn), respectively, indicating important roles of RANKL and FcRn in denosumab disposition.

In cynomolgus monkeys, a species in which denosumab binds RANKL, the intravenous pharmacokinetics of denosumab were non-linear over the dose range of 0.0016 to 1 mg/kg (with approximately 16-fold higher clearance at the lowest relative to highest dose) but were approximately dose-linear between 1 and 3 mg/kg. At all doses, the  $V_{ss}$  indicated a lack of extensive extravascular distribution. The subcutaneous pharmacokinetics of denosumab were also nonlinear in monkeys over the dose range of 0.0016 to 1 mg/kg, but were approximately dose-linear between 1 and 3 mg/kg.

## 10.2 Pharmacodynamics

In clinical studies, treatment with 60 mg of denosumab resulted in rapid reduction in the bone resorption marker serum type 1 C-telopeptide (CTX) within 6 hours of SC administration by approximately 70%, with reductions of approximately 85% occurring by 3 days. CTX levels were below the limit of assay quantitation (0.049 ng/mL) in 39 to 68% of subjects 1 to 3 months after dosing of denosumab. CTX reductions were maintained over the 6-month dosing interval. At the end of each dosing interval, CTX reductions were partially attenuated from maximal reduction of  $\geq 87\%$  to  $\geq 45\%$  (range 45% to 80%), as serum denosumab levels diminished, reflecting the reversibility of the effects of denosumab on bone remodelling. These effects were maintained with continued treatment. Consistent with the physiological coupling of bone formation and resorption in skeletal remodeling, subsequent reductions in bone formation markers were observed beginning 1 month after the first dose of denosumab.

Bone turnover markers (bone resorption and formation markers) generally reached pre-treatment levels within 9 months after the last 60 mg SC dose. Upon re-initiation, the degree of inhibition of CTX by denosumab was similar to that observed in patients initiating denosumab treatment.

In a clinical study of postmenopausal women with low bone mass (N = 504) who were previously treated with alendronate for a median duration of 3 years, those transitioning to receive denosumab experienced additional reductions in serum CTX, compared with women who remained on alendronate. In this study, the changes in serum calcium were similar between the 2 groups.

## 10.3 Pharmacokinetics

In dose ranging studies, denosumab exhibited nonlinear, dose-dependent pharmacokinetics for doses between 0.01 mg/kg to 3.0 mg/kg inclusive. Clearance or apparent clearance (mL/hr/kg) was higher at lower doses and had a linear inverse relationship with dose on a log-log plot. Exposures (SC dosing) based on area under the serum denosumab concentration-time curve

(AUC) increased greater than dose-proportionally from 0.01 to 1 mg/kg (700-fold for the 100-fold increase in dose), but approximately dose-proportionally from 1 to 3 mg/kg (3.9-fold for the 3-fold increase in dose).

**Figure 1. Individual Serum Denosumab Concentration-Time Profiles Following Single Dose SC Administration at 1.0 mg/kg to Healthy Postmenopausal Women**

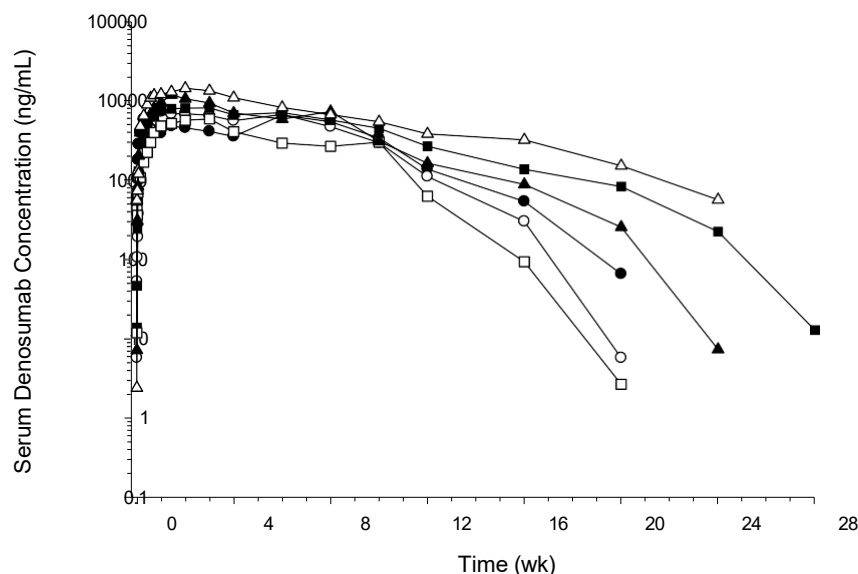

**Table 7. Mean (SD) Denosumab Pharmacokinetic Parameters Following Single Dose SC Administration of 1.0 mg/kg Denosumab to Healthy Postmenopausal Women (N = 6)**

Tmax (days)	Cmax (mcg/mL)	AUC0-inf (mcg x day/mL)	CL/F (mL/hr)	MRT (days)	t <sub>1/2</sub> (days)	t <sub>1/2,z</sub> (days)
17.5 (7 - 42)	8.99 (3.34)	538 (224)	6.61 (2.93)	44.2 (6.96)	30.2 (7.04)	8.00 (0.975)

SD = standard deviation; Cmax = Maximum observed concentration; Tmax = time of Cmax (range reported instead of SD); AUC0-inf = Area under the serum concentration-time curve from pre- dose to infinity; CL/F = apparent clearance; MRT = mean residence time; t<sub>1/2</sub> = half-life following Cmax; t<sub>1/2,z</sub> = terminal-phase half-life

**Table 8. Mean (SD) Denosumab Pharmacokinetic Parameters Following SC Administration of 60 mg Denosumab Every 6 Months to Postmenopausal Women with Low BMD (n = 32 to 46)\***

Dose	Tmax (days)	Cmax (mcg /mL)	AUC0-tau (mcgx day/mL)	CL/F (mL/hr)	MRT (days)	t <sub>1/2</sub> (days)	Cmin (mcg/mL)
1 <sup>st</sup>	26 (2.9 - 32)	7.93 (2.95)	503 (239)	6.71 (5.00)	44.2 (9.48)	25.4 (8.47)	0.137 (0.334)
2 <sup>nd</sup>	29 (1.9 - 42)	6.94 (3.18)	448 (239)	7.50 (5.04)	45.0 (9.99)	27.1 (8.99)	0.132 (0.334)

SD = standard deviation; Cmax = Maximum observed concentration; Tmax = time of Cmax (range reported

instead of SD); AUC<sub>0-tau</sub> = area under the serum denosumab concentration-time curve over the dosing interval; CL/F = apparent clearance; MRT = mean residence time; t<sub>1/2</sub> = half-life following C<sub>max</sub>; C<sub>min</sub> = trough serum denosumab concentration

\*1<sup>st</sup> dose: n = 46 for T<sub>max</sub>, C<sub>max</sub>, AUC<sub>0-tau</sub>, CL/F, & MRT; n = 32 for t<sub>1/2</sub>; n = 38 for C<sub>min</sub>

\*2<sup>nd</sup> dose: n = 44 for T<sub>max</sub>, C<sub>max</sub>, AUC<sub>0-tau</sub>, CL/F, & MRT; n = 33 for t<sub>1/2</sub>; n = 39 for C<sub>min</sub>

Denosumab pharmacokinetic parameters were not affected by the formation of binding antibodies to denosumab.

At the level of the administered dose, the pharmacokinetics of denosumab do not appear to be affected by gender, age (28 to 87 years), race, or disease state.

In a study of 17 postmenopausal women with osteoporosis, midazolam (2 mg oral) was administered two weeks after a single dose of denosumab (60 mg SC), which approximates the median time to maximum denosumab concentration (T<sub>max</sub>) of 10 days (range: 3 to 21 days). Denosumab did not affect the pharmacokinetics of midazolam, which is metabolized by cytochrome P450 3A4 (CYP3A4). This indicates that denosumab is not expected to alter the pharmacokinetics of drugs metabolized by CYP3A4 in postmenopausal women with osteoporosis.

### **Seminal Fluid Pharmacokinetic Study**

Serum and seminal fluid concentrations of denosumab were measured in 12 healthy male volunteers (age range: 43 to 65 years). After a single 60 mg subcutaneous administration of denosumab, C<sub>max</sub> [mean (± SD)] values in the serum and seminal fluid samples were 6170 (± 2070) and 100 (± 81.9) ng/mL, respectively, resulting in maximum denosumab concentrations in seminal fluid that were approximately 0 to 5% of serum levels. The median (range) T<sub>max</sub> values in serum and seminal fluid were estimated as 8.0 (7.9 to 21) and 21 (8.0 to 49) days, respectively. At the last measurement (approximately 15 weeks post-dose), 5 out of 12 subjects had quantifiable concentrations of denosumab in seminal fluid; the mean (± SD) was 21.1 (± 36.5) ng/mL across all subjects.

### **Special Populations and Conditions**

- **Pediatrics**

DENOZA is not indicated for use in pediatric populations.

- **Geriatrics**

The pharmacokinetics of denosumab were not affected by age.

- **Ethnic Origin**

The pharmacokinetics of denosumab were not affected by race in post-menopausal women.

- **Hepatic Insufficiency**

No clinical studies have been conducted to evaluate the effect of hepatic impairment on the pharmacokinetics of denosumab.

- **Renal Insufficiency**

In a study of 55 patients with varying degrees of renal function, including patients on dialysis, the degree of renal impairment had no effect on the pharmacokinetics of denosumab; thus, dose adjustment for renal impairment is not necessary.

#### **10.4 Immunogenicity**

All therapeutic proteins have the potential for immunogenicity.

The detection of antibody formation is highly dependent on the sensitivity and specificity of the assay. Additionally, the observed incidence of antibody (including neutralizing antibody) positivity in an assay may be influenced by several factors including assay methodology, sample handling, timing of sample collection, concomitant medications, and underlying disease. For these reasons, comparison of incidence of antibodies in the studies described below with the incidences of antibodies in other studies or to other products may be misleading.

More than 13000 patients were screened for binding antibodies using a sensitive electrochemiluminescent bridging immunoassay. Less than 1% (55 out of 8113) of patients treated with denosumab for up to 5 years tested positive for antibodies (including pre-existing, transient, and developing antibodies). The patients that tested positive for binding antibodies were further evaluated for neutralizing antibodies using a chemiluminescent cell-based *in vitro* biological assay and none of them tested positive. No evidence of altered pharmacokinetic profile, toxicity profile, or clinical response was associated with binding antibody development.

#### **11 Storage, Stability, and Disposal**

Store DENOZA in a refrigerator at 2°C to 8°C in the original carton. Do not freeze.

If removed from the refrigerator, DENOZA should be kept at controlled room temperature (up to 25°C) in the original carton and must be used within 30 days.

Protect DENOZA from light and do not expose to temperatures above 25°C.

Avoid vigorous shaking of DENOZA.

Do not use DENOZA beyond the expiry date stamped on the label.

## Part 2: Scientific Information

### 13 Pharmaceutical Information

#### Drug Substance

Non-proprietary name of the drug substance(s): denosumab

Molecular formula and molecular mass: 147 kDa (approximate)

Structure (for biologics): Denosumab is a fully human IgG2 monoclonal antibody heterotetramer consisting of 2 heavy chains of the gamma 2 subclass (447 amino acids per chain) and 2 light chains of the kappa subclass (215 amino acids per chain).

Physicochemical properties: DENOZA (denosumab) is a colourless to yellowish solution.

#### Product Characteristics:

Denosumab is produced in genetically engineered mammalian (Chinese Hamster Ovary) cells.

### 14 Clinical Trials

#### 14.1 Clinical Trials by Indication

##### Treatment of Osteoporosis in Postmenopausal Women

In postmenopausal women with osteoporosis, the safety and efficacy of denosumab were assessed in a randomized double-blind controlled study.

**Table 9. Study 1 (FREEDOM)**

Study #	Study design	Dosage, route of administration and duration	Study subjects (n)	Age (range)
Study 1 (FREEDOM)	Phase 3, randomized, double-blind, placebo- controlled	denosumab 60 mg or placebo SC injection every 6 months for 3 years	7808 patients with osteoporosis (denosumab: 3902 Placebo: 3906)	72 (60, 91)

The efficacy and safety of denosumab administered once every 6 months for 3 years were investigated in postmenopausal women (7,808 women aged 60 to 91 years, of which 23.6% had prevalent vertebral fractures) with baseline bone mineral density (BMD) T-scores at the lumbar spine or total hip between -2.5 and -4.0 and a mean absolute 10-year fracture probability of

18.60% (deciles: 7.9 to 32.4%) for major osteoporotic fracture and 7.22% (deciles: 1.4 to 14.9%) for hip fracture. Women with other diseases or on therapies that may affect bone (such as rheumatoid arthritis, osteogenesis imperfecta, and Paget's disease) were excluded from this study. Women were randomized to receive SC injections of either placebo (n = 3906) or denosumab 60 mg (n = 3902) once every 6 months. Women received calcium (at least 1,000 mg) and vitamin D (at least 400 IU) supplementation daily. The primary efficacy variable was the incidence of new vertebral fractures over 3 years. Secondary efficacy variables included the incidence of non-vertebral fracture and hip fracture, assessed over 3 years. The study was powered to detect a 45% reduction in the incidence of new vertebral fractures, a 40% decrease in the risk of non-vertebral fractures and a 40% decrease in the risk of hip fractures.

### **Effects on Fracture Incidence**

#### *New Vertebral Fractures*

Denosumab, when taken with calcium and vitamin D and compared with calcium and vitamin D alone, significantly reduced the incidence of new vertebral fractures over 36 months from 7.2% in the placebo group to 2.3% in the denosumab group ( $p < 0.0001$ ). The absolute reduction in risk of vertebral fractures was 4.8% and the relative reduction was 68% (Table 10). The number needed to treat (NNT) over the three years to prevent 1 new vertebral fracture was 20.7 (95% CI: 17.3, 25.8).

**Table 10. The Effect of denosumab on Vertebral Fracture Incidence over 3 Years**

	Proportion of Women with Fracture (%)		Absolute Risk Reduction (%) (95% CI)	Relative Risk Reduction (%) (95% CI)
	Placebo N = 3691 (%)	denosumab N = 3702 (%)		
0 - 1 Year	2.2	0.9	1.4 (0.8, 1.9)	61 (42, 74)*
0 - 2 Years	5.0	1.4	3.5 (2.7, 4.3)	71 (61,79)*
0 - 3 Years	7.2	2.3	4.8 (3.9, 5.8)	68 (59, 74)*

\* $p < 0.0001$

N = Number of women in the primary efficacy analysis set

In the long-term, open-label extension of Study 1, among 2343 women who received denosumab in Study 1 and continued on therapy (years 4 through 10 of denosumab treatment), 1343 (57.3%) completed 10 years. Denosumab treatment maintained a low incidence of new vertebral fractures in years 4 through 10 (149 [7.0%] women had at least one new vertebral fracture and 43 [2.4%] women had a clinical vertebral fracture by year 7 of the extension study). The yearly incremental incidences of new vertebral fractures remained low (see [Table 11](#)).

Among 2207 women who crossed over to denosumab from placebo in Study 1, 1283 (58.1%) completed 10 years, and the incidence of new vertebral fractures was low (145 [7.3%] had at

least one new vertebral fracture and 33 [1.9%] had a clinical vertebral fracture by year 7 of the extension study). The yearly incremental incidences of new vertebral fractures remained low (see [Table 11](#)).

**Table 11. The Effect of denosumab on the Yearly Incidence of New Vertebral Fracture in the Extension Study**

Long-term denosumab Group <sup>1</sup>		Cross-over denosumab Group <sup>2</sup>	
Exposure to denosumab	Proportion of Women with New Vertebral Fractures (%) <sup>3</sup>	Exposure to denosumab	Proportion of Women with New Vertebral Fractures (%) <sup>3</sup>
Year 4	1.5 <sup>4</sup> (N = 2116)	Year 1	0.9 <sup>4</sup> (N = 1991)
Year 5		Year 2	
Year 6	1.2 (N = 1809)	Year 3	1.5 (N = 1695)
Year 7	1.4 <sup>4</sup> (N = 1585)	Year 4	1.9 <sup>4</sup> (N = 1508)
Year 8		Year 5	
Year 9	1.3 <sup>4</sup> (N = 1323)	Year 6	1.6 <sup>4</sup> (N = 1267)
Year 10		Year 7	

<sup>1</sup> Long-term denosumab group: women who received denosumab in Study 1 and continued on therapy in the extension

<sup>2</sup> Cross-over denosumab group: women who received placebo in Study 1 and transitioned to denosumab in the extension

<sup>3</sup> Based on crude incidence

<sup>4</sup> Annualized yearly subject incidence

### *Hip Fractures*

The incidence of hip fracture was 1.2% for placebo-treated women compared to 0.7% for denosumab-treated women. The observed absolute reduction in the risk of hip fracture at 3 years was 0.3%, with a 95% CI across the zero (-0.1%, 0.7%), and the relative risk reduction was 40% (95% CI: 0.37, 0.97;  $p = 0.0362$ ).

Among women who received denosumab for 3 years in Study 1 and continued on therapy in the long-term, open-label extension, denosumab treatment maintained a low incidence of hip fractures in years 4 through 10 (22 [1.2%] women had at least one hip fracture). The yearly incremental incidences of hip fractures remained low (0.3%, <0.1%, 0.2%, 0.1%, 0.2%, <0.1%, and 0.4% during 4, 5, 6, 7, 8, 9 and 10 years of exposure to denosumab, respectively).

Women who crossed over to denosumab from placebo in Study 1, had a low incidence of hip fractures by year 7 of the extension study (26 [1.4%] women had at least one hip fracture). The yearly incremental incidences of hip fractures remained low (0.6%, 0.1%, 0.2%, <0.1%, 0.1%, 0.1% and 0.2% during 1, 2, 3, 4, 5, 6 and 7 years of exposure to denosumab, respectively).

### *Non-vertebral Fractures*

The incidence of non-vertebral fracture was 8.0% for placebo-treated women, compared with 6.5% for denosumab-treated women. The observed absolute reduction in risk of non-vertebral fractures over 3 years was 1.5% (0.3, 2.7) and the relative risk reduction was 20% (95% CI: 5, 33%;  $p = 0.0106$ ).

The incidences of nonvertebral fractures at other locations were as follows: distal femur (3 [ $< 0.1\%$ ] placebo, 0 [0%] denosumab), forearm (120 [3.1%] placebo, 103 [2.6%] denosumab), wrist (107 [2.7%] placebo, 90 [2.3%] denosumab), humerus (45 [1.2%] placebo, 38 [1.0%] denosumab), proximal humerus (41 [1.0%] placebo, 30 [0.8%] denosumab), clavicle/rib (25 [0.6%] placebo, 34 [0.9%] denosumab), proximal tibia (5 [0.1%] placebo, 3 [ $< 0.1\%$ ] denosumab), and pelvic (13 [0.3%] placebo, 10 [0.3%] denosumab).

Among women who received denosumab for 3 years in Study 1 and continued on therapy in the long-term, open-label extension, denosumab treatment maintained a low incidence of nonvertebral fractures in years 4 through 10 (172 [9.3%] women had at least one nonvertebral fracture). The yearly incremental incidences of nonvertebral fractures remained low (1.5%, 1.2%, 1.8%, 1.6%, 0.8%, 1.1% and 1.9% during 4, 5, 6, 7, 8, 9 and 10 years of exposure to denosumab, respectively). The most common sites for nonvertebral fractures during the long-term, open-label extension of Study 1 were wrist ( $n = 70$ ), rib/clavicle ( $n = 23$ ), hip ( $n = 22$ ), and ankle ( $n = 17$ ) (with  $n =$  number of affected women).

Among women who crossed over to denosumab from placebo in Study 1, 219 (12.3%) women had at least one nonvertebral fracture by year 7 of the extension study. The yearly incremental incidences of nonvertebral fractures remained low (2.5%, 2.0%, 2.6%, 1.2%, 1.8%, 1.5% and 1.7% during 1, 2, 3, 4, 5, 6 and 7 years of exposure to denosumab, respectively). The most common sites for nonvertebral fractures during the first 7 years in the extension were wrist ( $n = 91$ ), hip ( $n = 26$ ), ankle ( $n = 24$ ), humerus ( $n = 23$ ) and rib/clavicle ( $n = 20$ ).

### ***Effect on Bone Mineral Density (BMD)***

Treatment with denosumab significantly increased BMD at all clinical sites measured at 1, 2, and 3 years. denosumab increased lumbar spine BMD by 8.8%, total hip BMD by 6.4%, femoral neck BMD by 5.2%, and hip trochanter BMD by 8.3% over 3 years (all  $p < 0.0001$ ).

In the long-term, open-label extension of Study 1, in women who received denosumab in Study 1 and continued on therapy (years 4 through 10 of denosumab treatment), denosumab treatment continued to increase BMD from extension baseline at the lumbar spine (10.8%;  $n = 1264$ ), total hip (3.4%;  $n = 1232$ ), femoral neck (3.8%;  $n = 1232$ ) and trochanter (5.1%;  $n = 1232$ ) in years 4 through 10. Percent increase in BMD from the original Study 1 baseline (ie, after 10 years of treatment) in the long-term group was 21.7% at the lumbar spine, 9.2% at the total hip, 9.0% at the femoral neck and 13.0% at the trochanter (all  $n = 1251$ ). Annualized changes in BMD in the long-term, open-label extension portion of Study 1 are shown in [Table 12](#).

Among women who crossed over to denosumab from placebo in Study 1, BMD gains from extension baseline were 16.5% (lumbar spine;  $n = 1223$ ), 7.4% (total hip;  $n = 1200$ ), 7.1% (femoral neck;  $n = 1200$ ), and 10.3% (trochanter;  $n = 1200$ ) after 7 years of denosumab

administration. Annualized changes in BMD in the cross-over, open-label extension portion of Study 1 are shown in [Table 12](#).

**Table 12. Bone Mineral Density Yearly Percent Change by Site in the Extension Study**

Long-term denosumab Group					Cross-over denosumab Group				
Exposure to denosumab	Lumbar Spine % (n)	Total Hip % (n)	Femoral Neck % (n)	Trochanter % (n)	Exposure to denosumab	Lumbar Spine % (n)	Total Hip % (n)	Femoral Neck % (n)	Trochanter % (n)
Year 4	1.8 (2087)	0.8 (2065)	0.9 (2065)	1.1 (2065)	Year 1	5.4 (1980)	3.1 (1941)	2.3 (1941)	4.1 (1941)
Year 5	1.7 (2017)	0.6 (1998)	0.4 (1998)	0.9 (1998)	Year 2	2.5 (1898)	1.1 (1870)	1.1 (1870)	1.4 (1870)
Year 6	1.5 (1572)	0.5 (1549)	0.5 (1549)	0.8 (1549)	Year 3	1.7 (1468)	0.8 (1439)	0.8 (1439)	1.2 (1439)
Year 7	1.6 <sup>a</sup>	0.4 <sup>a</sup>	0.6 <sup>a</sup>	0.6 <sup>a</sup>	Year 4	1.8 <sup>a</sup>	0.7 <sup>a</sup>	0.8 <sup>a</sup>	0.9 <sup>a</sup>
Year 8	(136 1)	(133 0)	(133 0)	(133 0)	Year 5	(128 1)	(125 2)	(125 2)	(125 2)
Year 9	1.6 <sup>a</sup>	0.4 <sup>a</sup>	0.5 <sup>a</sup>	0.7 <sup>a</sup>	Year 6	1.8 <sup>a</sup>	0.6 <sup>a</sup>	0.7 <sup>a</sup>	0.9 <sup>a</sup>
Year 10	(124 5)	(120 6)	(120 6)	(120 6)	Year 7	(120 6)	(117 4)	(117 4)	(117 4)

<sup>a</sup> Annualized yearly change

n = Number of subjects with observed data at both time points of interest

### **Bone Histology and Histomorphometry**

A total of 115 transiliac crest bone biopsy specimens were obtained from 92 postmenopausal women with osteoporosis at either month 24 and/or month 36 (53 specimens in denosumab group, 62 specimens in placebo group). Of the biopsies obtained, 115 (100%) were adequate for qualitative histology and 7 (6%) in the denosumab group were adequate for full quantitative histomorphometry assessment.

Qualitative histology assessments showed normal architecture and quality with no evidence of mineralization defects, woven bone, or marrow fibrosis in patients treated with denosumab.

Fifty-nine women participated in the bone biopsy sub-study at month 24 (N = 41) and/or month 84 (N = 22) of the extension study, representing up to 5 and 10 years of treatment with denosumab, respectively. Bone biopsy results showed bone of normal architecture and quality with no evidence of mineralization defects, woven bone or marrow fibrosis as well as the expected decrease in bone turnover.

The presence of double tetracycline labeling in a biopsy specimen provides an indication of

active bone remodeling, while the absence of tetracycline label suggests suppressed bone formation. In subjects treated with denosumab, 35% had no tetracycline label present at the month 24 biopsy and 38% had no tetracycline label present at the month 36 biopsy, while 100% of placebo-treated patients had double label present at both time points. When compared to placebo, treatment with denosumab resulted in virtually absent activation frequency and markedly reduced bone formation rates. However, the long-term consequences of this degree of suppression of bone remodeling are unknown.

### Treatment to Increase Bone Mass in Men with Osteoporosis at High Risk for Fracture

In men with osteoporosis, the efficacy and safety of denosumab were assessed in a randomized, double-blind, placebo-controlled study.

**Table 13. Study 5 (ADAMO)**

Study #	Study design	Dosage, route of administration and duration	Study subjects (n)	Age (range)
Study 5 (ADAMO)	Phase 3, randomized, double-blind, placebo-controlled	denosumab 60 mg or placebo SC injection every 6 months (Q6M) (2 doses)	242 men with osteoporosis (denosumab: 121 Placebo: 121)	65 (31, 84)

The efficacy and safety of denosumab in increasing bone mass in men with osteoporosis was demonstrated in a 1-year, randomized, double-blind, placebo-controlled, multinational study of men with low bone mass, who had a baseline BMD T-score between  $-2.0$  and  $-3.5$  at the lumbar spine or femoral neck. Men with a BMD T-score between  $-1.0$  and  $-3.5$  at the lumbar spine or femoral neck and with history of prior fragility fracture were also enrolled. Men with other diseases (such as rheumatoid arthritis, osteogenesis imperfecta, and Paget's disease) or on therapies that may affect bone were excluded from this study.

The 242 men enrolled in the study ranged in age from 31 to 84 years and were randomized to receive SC injections of either denosumab 60 mg ( $n = 121$ ) or placebo ( $n = 121$ ) once every 6 months. Patients also received at least 1000 mg calcium and at least 800 IU vitamin D supplementation daily.

Previous fractures in the denosumab and placebo groups were: 91 events in 47 patients (38.8%) vs. 76 events in 48 patients (39.7%) for any self-reported historical fractures since age 30, 18 events in 16 patients (13.2%) vs. 21 events in 20 patients (16.5%) for self-reported historical major osteoporotic fractures, and 43 events in 30 patients (24.8%) vs. 31 events in 25 patients (20.7%) for confirmed prevalent vertebral fractures, respectively.

The primary efficacy variable was percent change in lumbar spine BMD from baseline to 1 year. Secondary efficacy variables included percent change in total hip and femoral neck BMD from baseline to 1 year.

### **Effect on Bone Mineral Density (BMD)**

Treatment with denosumab statistically significantly increased BMD at 1 year: the treatment differences in BMD at 1 year were: 4.8% (+5.7% denosumab, +0.9% placebo,  $p < 0.0001$  [95% CI: 4.0%, 5.6%]) at the lumbar spine; 2.0% (+2.4% denosumab, +0.3% placebo) at the total hip; and 2.2% (+2.1% denosumab, 0.0% placebo) at femoral neck.

Consistent effects on BMD were observed at the lumbar spine regardless of baseline age, race, weight/body mass index (BMI), BMD, baseline testosterone levels and level of bone turnover. The correlation between increased bone density and reduction of bone fracture in men with osteoporosis has not been established.

### **Bone Histology and Histomorphometry**

The transiliac crest bone biopsy substudy enrolled 29/242 patients at selected study centres in Study 5 (17 specimens in denosumab group, 12 specimens in placebo group), after 12 months of treatment. Six (6) of the samples in the denosumab group were adequate for full quantitative histomorphometry assessment. Qualitative histology assessments showed normal architecture and quality with no evidence of mineralization defects, woven bone, or marrow fibrosis in patients treated with denosumab.

All subjects scheduled for the biopsy were to follow a double tetracycline/demeclocycline labelling procedure prior to undergoing the biopsy. The presence of double tetracycline labeling in a biopsy specimen provides an indication of active bone remodeling, while the absence of tetracycline label suggests suppressed bone formation. In patients treated with denosumab, 6% ( $n = 1$ ) had no tetracycline label present at the month 12 biopsy, while 100% of placebo-treated patients ( $n = 12$ ) had double label present. When compared to placebo, treatment with denosumab resulted in markedly reduced bone formation rates. However, the long-term consequences of this degree of suppression of bone remodeling are unknown.

### **Treatment to Increase Bone Mass in Men with Nonmetastatic Prostate Cancer receiving Androgen Deprivation Therapy (ADT), Who Are at High Risk for Fracture**

**Table 14. Study 6**

<b>Study #</b>	<b>Study design</b>	<b>Dosage, route of administration and duration</b>	<b>Study subjects (n)</b>	<b>Age (range)</b>
Study 6	Phase 3, randomized, double-blind, placebo-controlled	denosumab 60 mg or placebo SC injection every 6 months for 3 years	1468 patients with nonmetastatic prostate cancer (denosumab: 734 Placebo: 734)	75 (48, 97)

The efficacy and safety of denosumab in the treatment of bone loss in men with nonmetastatic prostate cancer receiving androgen deprivation therapy (ADT) were demonstrated in a 3 year, randomized (1:1), double-blind, placebo-controlled, multinational study.

Men less than 70 years of age had either a BMD T-score at the lumbar spine, total hip, or

femoral neck between -1.0 and -4.0, or a history of an osteoporotic fracture. The mean baseline lumbar spine BMD T-score was -0.4, and 22% of men had a vertebral fracture at baseline. The 1468 men enrolled ranged in age from 48 to 97 years (mean 75 years). Men were randomized to receive subcutaneous injections of either placebo (n = 734) or denosumab 60 mg (n = 734) once every 6 months for a total of 6 doses. Randomization was stratified by age (< 70 years vs. ≥ 70 years) and duration of ADT at trial entry (≤ 6 months vs. > 6 months). All men regardless of age had histologically confirmed prostate cancer. Seventy-nine percent of patients received ADT for more than 6 months at study entry. All men were instructed to take at least 1000 mg calcium and 400 IU vitamin D supplementation daily.

### ***Effect on Bone Mineral Density (BMD)***

The primary efficacy variable was percent change in lumbar spine BMD from baseline to month 24. Lumbar spine BMD was higher at 2 years in denosumab-treated patients as compared to placebo-treated patients [-1.0% placebo, +5.6% denosumab; treatment difference 6.7% (95% CI: 6.2, 7.1); p < 0.0001].

With approximately 62% of patients followed for 3 years, treatment differences in BMD at 3 years were 7.9% (-1.2% placebo, +6.8% denosumab) at the lumbar spine, 5.7% (-2.6% placebo, +3.2% denosumab) at the total hip, and 4.9% (-1.8% placebo, +3.0% denosumab) at the femoral neck (p < 0.0001). Consistent effects on BMD were observed at the lumbar spine in relevant subgroups defined by baseline age, race, geographical region, weight/BMI, BMD, level of bone turnover, duration of ADT, and baseline history of vertebral fracture.

### ***Effect on Vertebral Fractures***

An additional key secondary efficacy variable was the incidence of new vertebral fracture through month 36 diagnosed based on x-ray evaluation by two independent radiologists. The incidence of new vertebral fracture through month 12 and through month 24 were evaluated as exploratory endpoints. The subject-year adjusted incidence rate of new vertebral fractures at 3 years was 0.6 and 1.6 per 100 subject-years for denosumab and placebo, respectively. denosumab significantly reduced the incidence of new vertebral fractures at 3 years (adjusted p = 0.0125). The relative risk reduction based on cumulative incidence of new vertebral fractures at 3 years was 62% (adjusted 95% Confidence Interval: 13, 83) (2.4% absolute risk reduction; adjusted 95% Confidence Interval: 0.4, 4.4). The relative risk reduction of new vertebral fractures was 85% (1.6% absolute risk reduction) at 1 year and 69% (2.2% absolute risk reduction) at 2 years.

## **Treatment to Increase Bone Mass in Women Receiving Adjuvant AI Therapy for Nonmetastatic Breast Cancer Who Have Low Bone Mass and Are at High Risk for Fracture**

**Table 15. Study 7**

<b>Study #</b>	<b>Study design</b>	<b>Dosage, route of administration and duration</b>	<b>Study subjects (n)</b>	<b>Age (range)</b>

Study 7	Phase 3, randomized, double-blind, placebo-controlled	denosumab 60 mg or placebo SC injection every 6 months for 2 years	252 patients with nonmetastatic breast cancer (denosumab: 127 Placebo: 125)	60 (35, 84)
---------	---	--	---	-------------

The efficacy and safety of denosumab in the treatment of bone loss in women receiving adjuvant aromatase inhibitor (AI) therapy for breast cancer was assessed in a 2 year, randomized (1:1), double-blind, placebo-controlled, multinational study.

Women had baseline BMD T-scores between -1.0 to -2.5 at the lumbar spine, total hip, or femoral neck, and had not experienced fracture after age 25. The mean baseline lumbar spine BMD T-score was -1.1, and 2.0% of women had a vertebral fracture at baseline. The 252 women enrolled ranged in age from 35 to 84 years (mean 60 years). Women were randomized to receive subcutaneous injections of either placebo (n = 125) or denosumab 60 mg (n = 127) once every 6 months for a total of 4 doses. Randomization was stratified by duration of adjuvant AI therapy at trial entry ( $\leq$  6 months vs.  $>$  6 months). Sixty-two percent of patients received adjuvant AI therapy for more than 6 months at study entry. All women were instructed to take 1000 mg calcium and at least 400 IU vitamin D supplementation daily.

#### ***Effect on Bone Mineral Density (BMD)***

The primary efficacy variable was percent change in lumbar spine BMD from baseline to month 12. Lumbar spine BMD was higher at 12 months in denosumab-treated patients as compared to placebo-treated patients [-0.7% placebo, +4.8% denosumab; treatment difference 5.5% (95% CI: 4.8, 6.3);  $p < 0.0001$ ].

With approximately 81% of patients followed for 2 years, treatment differences in BMD at years were 7.6% (-1.4% placebo, +6.2% denosumab) at the lumbar spine, 4.7 % (-1.0% placebo, +3.8% denosumab) at the total hip, and 3.6% (-0.8% placebo, +2.8% denosumab) at the femoral neck.

#### **Treatment and Prevention of Glucocorticoid-Induced Osteoporosis (GIOP) in Men and Women at High Risk for Fracture**

**Table 16. Study 8**

Study #	Study design	Dosage, route of administration and duration	Study subjects (n)	Age (range)
Study 8	Phase 3, randomized, multicenter, double-blind, double-dummy, parallel group,	denosumab 60 mg SC injection once every 6 months or oral risedronate 5 mg once daily for 1	795 patients (70% women, 30% men) denosumab Glucocorticoid-initiating: 145 Glucocorticoid-continuing: 253	63 (20,94)

	active- controlled	year	Risedronate Glucocorticoid-initiating: 145 Glucocorticoid- continuing: 252	
--	--------------------	------	---	--

Men and women aged 20 to 94 years (mean age of 63 years) who were being treated with glucocorticoids ( $\geq 7.5$  mg daily prednisone or its equivalent) for an expected duration of 6 months or longer for rheumatic, respiratory, skin, or other inflammatory diseases were enrolled. Two subpopulations were studied: glucocorticoid-continuing (patients who received glucocorticoids for  $\geq 3$  months prior to screening;  $n = 505$ ) and glucocorticoid-initiating (patients who received glucocorticoids for  $< 3$  months prior to screening;  $n = 290$ ). All enrolled patients  $< 50$  years of age had a history of osteoporotic fracture. All enrolled patients  $\geq 50$  years of age who were in the glucocorticoid-continuing subpopulation had baseline bone mineral density (BMD) T-scores of  $\leq -2.0$  at the lumbar spine, total hip, or femoral neck; or a BMD T-score  $\leq -1.0$  at the lumbar spine, total hip, or femoral neck and a history of osteoporotic fracture.

Patients were randomized (1:1) to receive either denosumab 60 mg subcutaneously once every 6 months ( $n = 398$ ) or oral risedronate 5 mg once daily (active control) ( $n = 397$ ). Within each subpopulation, randomization was stratified by gender. All patients were instructed to take at least 1000 mg calcium and 800 IU vitamin D supplementation daily.

### ***Effect on Bone Mineral Density (BMD)***

The primary efficacy endpoint was percent change in lumbar spine BMD from baseline to month 12. In the glucocorticoid-continuing subpopulation, the percent change from baseline in lumbar spine BMD was higher at 1 year in denosumab-treated patients compared to risedronate-treated patients [(denosumab +4.4%, risedronate +2.3%; treatment difference 2.1% (95% CI: 1.4, 3.0,  $p < 0.001$ )] ([Table 17](#)). In the glucocorticoid-initiating subpopulation, the percent change from baseline in lumbar spine BMD was higher at 1 year in denosumab-treated patients as compared to risedronate-treated patients [(denosumab +3.8%, risedronate + 0.8%; treatment difference 3.0% (95% CI: 2.0, 3.9,  $p < 0.001$ )).

Consistent results for total hip BMD were observed in both subpopulations.

The correlation between increased bone mineral density and reduction of bone fracture incidence in patients with glucocorticoid-induced osteoporosis has not been directly established.

**Table 17. Results of Study 8 in Women and Men with Glucocorticoid-induced Osteoporosis at High Risk for Fracture (denosumab vs. Risedronate)**

Sub-population	Location	denosumab Mean % change in BMD after 1 year (95% CI)	Risedronate Mean % change in BMD after 1 year (95% CI)	Treatment Difference Mean (95% CI)	p-value
Glucocorticoid- continuing	Lumbar Spine	4.4 (3.8, 5.0) (N = 209)	2.3 (1.7, 2.9) (N = 211)	2.1 (1.4, 3.0)	< 0.001*
	Total hip	2.1 (1.7, 2.5) (N = 217)	0.6 (0.2, 1.0) (N = 215)	1.5 (1.0, 2.1)	< 0.001*
Glucocorticoid- initiating	Lumbar Spine	3.8 (3.1, 4.5) (N = 119)	0.8 (0.2, 1.5) (N = 126)	3.0 (2.0, 3.9)	< 0.001*
	Total hip	1.7 (1.2, 2.2) (N = 119)	0.2 (-0.2, 0.7) (N = 128)	1.5 (0.8, 2.1)	< 0.001*

\* p-value adjusted for multiplicity within each subpopulation. Based on an ANCOVA model adjusting for treatment, baseline BMD, gender, machine type, and baseline BMD-by-machine type interaction. For glucocorticoid-continuing subpopulation, duration of prior glucocorticoid use (< 12 months vs ≥ 12 months) was included as an additional covariate.

## 15 Microbiology

No microbiological information is required for this drug product.

## 16 Non-Clinical Toxicology

### General Toxicology

Denosumab is a potent inhibitor of osteoclastic bone resorption via inhibition of RANK ligand (RANKL).

In ovariectomized monkeys, once-monthly treatment with denosumab suppressed bone turnover and caused significant gain in BMD, and strength of cancellous and cortical bone. Bone tissue was normal with no evidence of mineralization defects, accumulation of osteoid, or woven bone.

Transition from 6-month alendronate treatment to denosumab in monkeys did not cause any meaningful decreases in serum calcium and significantly increased or maintained BMD of the whole body, lumbar spine, and distal radius. Bone strength parameters at these sites were maintained or improved with transition to denosumab, relative to continuous treatment with alendronate. Bone strength and reduction in bone resorption at all skeletal sites were maintained or improved in monkeys switched from alendronate to denosumab.

Since the biological activity of denosumab in animals is specific to non-human primates, evaluation of genetically engineered (“knockout”) mice or use of other biological inhibitors of the RANK/RANKL pathway, namely OPG-Fc, provided additional information on the pharmacodynamic properties of denosumab. RANK/RANKL knockout mice exhibited impairment of lymph node formation, had an absence of lactation due to inhibition of mammary gland maturation (lobulo-alveolar gland development during pregnancy), and exhibited reduced bone growth and lack of tooth eruption. Similar phenotypic changes were seen in a corroborative study in 2-week old rats given the RANK ligand inhibitor OPG-Fc. After 10 weeks on study, these changes were partially reversible in this model when dosing with the RANKL inhibitors was discontinued. Refer to Table 18 Summary of Preclinical Toxicity and Reproductive Studies with Denosumab for details of the individual study results.

### **Genotoxicity**

The genotoxic potential of denosumab has not been evaluated. Denosumab is a recombinant protein made up entirely of naturally-occurring amino acids and contains no inorganic or synthetic organic linkers or other non-protein portions. Therefore, it is unlikely that denosumab or any of its derived fragments would react with DNA or other chromosomal material.

### **Carcinogenicity**

Since denosumab is highly species-specific and is not active in rodents, traditional rodent cancer bioassays could not be performed. RANKL inhibition (the target of denosumab) has been studied in a wide range of short-term animal models of cancer and shown no carcinogenic potential. Additionally, RANKL inhibition has shown no evidence of immunosuppression in a wide range of animal models.

### **Reproductive and developmental toxicology**

Denosumab had no effect on female fertility or male reproductive organs in monkeys at exposures that were 100- to 150-fold higher than the human exposure for 60 mg SC administered once every 6 months.

**Table 18. Summary of Preclinical Toxicity and Reproductive Studies with Denosumab**

Type of Study	Species and strain	Number per sex per group	Route of Administration	Dose (mg/kg) and dosing regimen	Study Duration	Treatment-related findings	NOAEL (mg/kg)
Repeated-dose Toxicity	Cynomolgus monkey	6	Subcutaneous (SC) or Intravenous (IV)	Once weekly: 0, 0.1, 1.0, & 10.0 (SC); 10.0 (IV)	1 month dosing with 3 months recovery	Consistent with the pharmacological action of denosumab, there were rapid and marked decreases in circulating markers of bone turnover at all doses. Correlating with these changes, there was increased bone mineral density in males dosed at 1 and 10 mg/kg. With the exception of bone mineral density which tended to be maintained, these changes were recovered or recovering following 3 treatment-free months.  There were no treatment related effects on organ weights or histopathology findings	10 (SC and IV)
	Cynomolgus monkey	8	Subcutaneous	Once monthly : 0, 1, 10, 50	6 and 12 months with 3 months recovery	Consistent with the pharmacological action of denosumab, there were rapid and marked decreases in circulating markers of bone turnover at 10 and 50 mg/kg. Correlating to these changes, there was increased bone mineral density, bone mineral content, cortical area and thickness, and bone strength parameters in	50

Type of Study	Species and strain	Number per sex per group	Route of Administration	Dose (mg/kg) and dosing regimen	Study Duration	Treatment-related findings	NOAEL (mg/kg)
						males dosed at 50 mg/kg, and females dosed at 10 and 50 mg/kg. In addition, there was enlargement of the growth plates, decreased osteoblasts and osteoclasts, and decreased chondroclasis at 10 and 50 mg/kg. These changes were recovered or recovering following 3 treatment-free months. There were no treatment related changes in ophthalmoscopy, cardiovascular physiology, sperm motility and morphology, circulating immunoglobulins and lymphocyte subsets, or organ weights.	
Female Fertility	Cynomolgus monkey	6 females	Subcutaneous	Once weekly: 0, 2.5, 5, 12.5	Over 2 menstrual cycles before mating and for 4 weeks after mating	No treatment related effects on cyclicity, circulating reproductive hormones, mating success.	12.5
Embryo-fetal Development	Cynomolgus monkey	16 females	Subcutaneous	Once weekly: 0, 2.5, 5, 12.5	Gestation days 20-50	No treatment related effects on mother or embryonic development were observed. Peripheral lymph nodes were not evaluated.	12.5
Enhanced pre-and	Cynomolgus monkey	29 females	Subcutaneous	Once monthly: 0,	Gestation days 20-22 to birth	There were increased fetal losses during gestation, increased stillbirths and	A NOAEL was not identified

Type of Study	Species and strain	Number per sex per group	Route of Administration	Dose (mg/kg) and dosing regimen	Study Duration	Treatment-related findings	NOAEL (mg/kg)
post-natal development				50		post-natal mortality (see Table 19.). Treatment-related findings in the offspring included decreased body weight gain and decreased neonatal growth; skeletal abnormalities resulting from impaired bone resorption during rapid growth, including bones at the base of the skull resulting in altered cranial shape and exophthalmos, reduced bone strength and treatment-related bone fractures; reduced hematopoiesis; decreased serum levels of bone resorption and bone formation biomarkers; tooth malalignment and dental dysplasia (in the absence of adverse effects on tooth eruption); infections; and absence of peripheral lymph nodes. Following a recovery period from birth out to 6 months of age, findings still observed were mildly reduced bone length (femoral, vertebral, jaw), reduced cortical thickness with associated reduced strength; extramedullary hematopoiesis; dental dysplasia; and the absence	d

Type of Study	Species and strain	Number per sex per group	Route of Administration	Dose (mg/kg) and dosing regimen	Study Duration	Treatment-related findings	NOAEL (mg/kg)
						<p>or decreased size of some lymph nodes. One infant had minimal to moderate mineralization in multiple tissues. The initially lower growth rates returned to, but never exceeded the growth rate in the control group, and hence, the infants exposed to denosumab remained smaller than control infants, as measured by body weight and morphometric measurements. For the denosumab-treated maternal animals, there was a decrease in serum levels of bone resorption and formation biomarkers, and serum alkaline phosphatase levels; recovery was evident by the end of the treatment-free period. Maternal mammary gland development was normal. At birth out to 1 month of age, infants had measurable blood levels of denosumab (22-621% of maternal levels). Only one infant had measurable concentrations of denosumab on BD91, and no infants had measurable concentrations on BD180.</p>	

Type of Study	Species and strain	Number per sex per group	Route of Administration	Dose (mg/kg) and dosing regimen	Study Duration	Treatment-related findings	NOAEL (mg/kg)
						Generally, the effects observed in mothers and infants were consistent with the pharmacological action of denosumab.	
Safety Pharmacology	Cynomolgus monkey	3 males	Subcutaneous	Single dose: 0, 0.3, 3, 30	7 days	No treatment related effects on heart rate, blood pressure, electrical activity of the heart, or respiratory rate were observed.	30
	Safety Pharmacology	Cynomolgus monkey	3 males	Subcutaneous	Single dose: 0, 0.3, 3, 30	7 days	No treatment related effects on heart rate, blood pressure, electrical activity of the heart, or respiratory rate were observed.
	Sprague Dawley weanling rats	71 males and 67 females	Subcutaneous	Rat OPG-Fc: 1, 10 mg/kg/week Murine RANK-Fc: 10 mg/kg/week	6 weeks	Increased bone volume, density and strength. Increased cancellous bone with reduced osteoclast number. Reduced long bone growth with altered growth plate morphology and increased thickness. Impaired tooth eruption and tooth root formation.	N/A

Type of Study	Species and strain	Number per sex per group	Route of Administration	Dose (mg/kg) and dosing regimen	Study Duration	Treatment-related findings	NOAEL (mg/kg)
	Sprague Dawley neonatal rats	51 males and 49 females	Subcutaneous	Rat OPG-Fc or ALN: 5 µL/g/week for 6 weeks followed by 10 week treatment-free period	16 weeks	Ten weeks after the discontinuation of a 6-week course of OPG-Fc administration, neonatal rats exhibited evidence of restored bone resorption and partial normalization of bone density, size, and strength. Molar eruption, which had been substantially delayed during the administration of OPG-Fc, exhibited partial recovery in some animals within 10 weeks of its discontinuation. The relative increases in bone volume, density, and strength that occurred during 6 weeks of ALN administration were generally preserved 10 weeks after its discontinuation, whereas molar eruption did not recover within this timeframe. Modest epiphyseal growth plate changes persisted 10 weeks after discontinuing high-dose OPG-Fc. Bone size, body weight, and molar root development remained significantly reduced 10 weeks after discontinuation of OPG-Fc or ALN when compared to the vehicle control group.	N/A

Type of Study	Species and strain	Number per sex per group	Route of Administration	Dose (mg/kg) and dosing regimen	Study Duration	Treatment-related findings	NOAEL (mg/kg)
Other Studies – Tissue Cross-reactivity	Cynomolgus monkey, rat, rabbit	N/A	In Vitro	5 or 25 mcg/mL	N/A	Staining of lymphoid tissue in rabbit and cynomolgus monkey and staining of chondrocytes in rat were observed.	N/A
	Cynomolgus monkey, human	N/A	In Vitro	1 or 10 mcg/mL	N/A	Staining of lymphoid tissue in monkey, but no staining in human tissue was observed.	N/A
	Human	N/A	In Vitro	1 or 10 mcg/mL	N/A	Staining of lymphoid tissue was observed.	N/A

N/A = not applicable; NOAEL = No Observed Adverse Effect Level

**Table 19. Total Fetal Losses<sup>c</sup>, all Groups**

Dose, (mg/kg)	Total No. Pregnant Females; Infants Born (M/F)	Gestation Day (GD) of Fetal Loss	% Fetal Loss by Dose Level			
			Full Gestation	First Trimester (GD20 to GD50)	Third Trimester Total (≥GD100)	Third Trimester Stillbirths (≥GD140)
0	29; 22 (13/9)	GDs 32, 32, 33, 104, 152, 157, 170	24.1% (7/29)	10.3% (3/29)	13.8% (4/29)	10.3% (3/29)
50	29; 16 (7/9)	GDs 31, 32, 33, 33, 46, 88 <sup>a</sup> , 132, 151, 156 <sup>a</sup> , 157, 158, 160, 168	40.7% (11/27) 44.8%** (13/29)	17.2% (5/29)	22.2% (6/27) 24.1%** (7/29)	18.5% (5/27) 20.7%** (6/29)
Historical Control Data <sup>b</sup>			24.8% (33/133)	6.8% (9/133)	15.8% (21/133)	9.0% (12/133)
Range			(6.7 to 38.9%)	(0 to 11.8%)	(0 to 28.6%)	(0 to 16.7%)

<sup>a</sup> Two adult females were excluded from fetal loss calculations except for first trimester because each had an

anti-drug antibody (ADA) response beginning at GD76 with subsequent decrease in pharmacologic effect (bone biomarkers) prior to fetal loss; results indicated by a double asterisk (\*\*) include these ADA-positive adult females.

<sup>b</sup> Based on 8 enhanced PPND studies conducted at the Testing Facility from 2008 to 2010.

<sup>c</sup> Fetal losses occurring prior to GD140 were considered abortions; those occurring on or after GD140 were considered stillbirths.

## **17 Supporting Product Monographs**

PROLIA® (denosumab injection 60 mg / mL solution for injection), control 276666, product monograph, Amgen Canada Inc.. 2023-11-24

## Patient Medication Information

### READ THIS FOR SAFE AND EFFECTIVE USE OF YOUR MEDICINE

Pr**DENOZA**<sup>™</sup>

#### Denosumab injection

This Patient Medication Information is written for the person who will be taking **DENOZA**. This may be you or a person you are caring for. Read this information carefully. Keep it as you may need to read it again.

This Patient Medication Information is a summary. It will not tell you everything about this medication. If you have more questions about this medication or want more information about **DENOZA**, talk to a healthcare professional.

**DENOZA** is a biosimilar biologic drug (biosimilar) to the reference biologic drug PROLIA<sup>®</sup>. A biosimilar is authorized based on its similarity to a reference biologic drug that was already authorized for sale in Canada.

#### What **DENOZA** is used for:

**DENOZA** is used for the treatment

- of osteoporosis (thinning and weakening of the bone) in women after menopause who
  - have an increased risk for fractures or;
  - cannot use other osteoporosis medicines, or other osteoporosis medicines did not work well.
- to increase bone mass in men with osteoporosis at high risk for fracture.
- to increase bone mass and may reduce fractures that occur when medication to reduce testosterone levels are taken for the treatment of prostate cancer that has not spread to other parts of the body (nonmetastatic).
- to increase bone mass in women who are receiving certain treatments for breast cancer, which has not spread to other parts of the body (nonmetastatic) and at high risk of fracture.
- to increase bone mass to treat osteoporosis in both women and men at high risk for fracture related to the use of corticosteroid medicines, such as prednisone.
- to increase bone mass to prevent osteoporosis in both women and men at high risk for fracture related to starting corticosteroid medicines, such as prednisone.

#### What osteoporosis is:

Bone is constantly changing. There are special cells in the body called osteoclasts whose primary function is to remove bone. There is another type of cell called osteoblasts, which are bone-forming cells. In normal bone, there is a balance between the actions of

these two cells. In people with osteoporosis, this balance no longer exists. Instead, the cells that remove bone work overtime, removing bone faster than new bone can be created. The result is bone that is thinner, weaker and more likely to break.

Osteoporosis may occur without any pain or other symptoms. Sometimes the first symptom of osteoporosis is a fragility fracture, a broken bone that may be caused by a minor fall, or simple activities such as lifting groceries or getting out of bed. A fragility fracture can significantly increase the risk of future fractures. Aside from prescribing DENOZA, your doctor can guide you in other ways to manage your bone health.

Surgery or medicines that stop the production of estrogen or testosterone used to treat patients with breast or prostate cancer can also lead to bone loss. This may cause some bones to become weaker and break more easily.

Corticosteroids, like prednisone, can also cause thinning and weakening of the bone increasing your chance of broken bones.

#### **How DENOZA works:**

DENOZA works differently than other osteoporosis medications. It is a RANK ligand inhibitor. RANK ligand is a protein which activates the cells that break down bone (osteoclasts). DENOZA blocks RANK ligand to stop the cells that break down bone. This action strengthens your bones by increasing bone mass and lowers the chance of breaking bones of the hip, spine, and nonspinal sites.

#### **The ingredients in DENOZA are:**

Medicinal ingredient: denosumab

Non-medicinal ingredients: sorbitol, acetic acid, polysorbate 20, water for injection and sodium hydroxide. The prefilled syringe is not made with natural rubber latex.

#### **DENOZA comes in the following dosage forms:**

DENOZA is a liquid for injection, available in a prefilled syringe.

DENOZA is a colourless to yellowish solution. Do not use if the solution is cloudy.

#### **Do not use DENOZA if:**

- you are allergic to denosumab or any other ingredient of DENOZA. Allergic reactions (eg, rash, hives, or in rare cases, swelling of the face, lips, tongue, throat, or trouble breathing) have been reported.
- you have low calcium levels in your blood (hypocalcemia).
- you are less than 18 years of age (see also [What DENOZA is used for](#) above and [Other warnings you should know about](#) below).
- you are pregnant or breastfeeding.
- you are a woman before menopause [unless you have been diagnosed with breast cancer or are taking DENOZA for the treatment or prevention of osteoporosis related

to the use of corticosteroid medicines (see also [What DENOZA is used for](#) above and [Other warnings you should know about](#) below)].

- you are currently taking denosumab-containing medicinal products.
- you do not have access to a healthcare professional or trained injector.

**To help avoid side effects and ensure proper use, talk to your healthcare professional before you take DENOZA. Talk about any health conditions or problems you may have, including if you:**

- Have low blood calcium.
- Cannot take daily calcium and vitamin D.
- Had parathyroid or thyroid surgery (glands located in your neck).
- Have been told you have trouble absorbing minerals in your stomach or intestines (malabsorption syndrome).
- Have kidney problems or are on kidney dialysis.
- Have ever had an allergic reaction to DENOZA.
- Plan to have dental surgery or teeth removed.
- Have a history of cancer.
- Are pregnant or could become pregnant.

DENOZA may interfere with normal bone and tooth development in fetuses, nursing babies, and children under 18 years of age. DENOZA is not indicated for use in patients under 18 years of age.

Do not take DENOZA if you are pregnant or could become pregnant as DENOZA may harm your unborn baby. Your healthcare provider should do a pregnancy test before you start treatment with DENOZA. You should use an effective method of birth control (contraception) during treatment with DENOZA and for at least 5 months after your last dose of DENOZA. If you become pregnant while taking DENOZA, stop taking DENOZA and tell your doctor right away.

Nursing mothers should not take DENOZA. It may also interfere with breastfeeding.

DENOZA may lower levels of calcium in the blood. If you are prone to low calcium levels, your doctor will monitor your blood, especially in the first few weeks after starting DENOZA. Severe low blood calcium levels may lead to hospitalization, life-threatening events, and death. Low blood calcium should be treated before receiving DENOZA. Symptoms of low blood calcium may include muscle spasms, twitches, cramps, numbness or tingling in hands, feet or around the mouth, and weakness. Some patients may not have any symptoms of low calcium. Tell your doctor if you have any of these symptoms. Tell your doctor if you have or have had severe kidney problems as this may increase your risk of getting low blood calcium.

Tell your doctor right away if you have symptoms of infection, including:

- Fever or chills
- Skin that looks red, swollen, hot or tender to touch
- Severe abdominal pain
- Frequent or urgent need to urinate or burning feeling when you urinate

Tell your doctor if you have any of the following symptoms of skin problems that do not go away or get worse:

- Redness
- Itching
- Rash
- Dry or leathery skin
- Open, crusted or peeling skin
- Blisters

After you start DENOZA:

- Take good care of your teeth and gums, and see your dentist regularly.
- If you have a history of dental problems (such as poorly fitting dentures or gum disease), see your dentist before starting DENOZA.
- Tell your dentist that you are taking DENOZA, especially if you are having dental work.

A dental condition called osteonecrosis of the jaw (ONJ) which can cause tooth and jawbone loss has been reported in patients treated with denosumab. The risk of ONJ may increase with length of time on DENOZA. Tell your doctor and dentist immediately about any dental symptoms, including pain or unusual feeling in your teeth or gums, or any dental infections.

Some people have developed unusual fractures in their thigh bone. Contact your doctor if you experience new or unusual pain in your hip, groin, or thigh.

After your treatment with DENOZA is stopped, it is possible that broken bones in your spine may occur especially if you have a history of broken bones in the spine. Do not stop taking DENOZA without first talking with your doctor. If your DENOZA treatment is stopped, discuss other available treatment options with your doctor.

**Other warnings you should know about:**

If you are being treated with DENOZA, you should not be taking other denosumab-containing medicinal products.

There is an increased risk of skin infection (cellulitis) with DENOZA therapy, most

commonly on the leg. See a doctor urgently if you develop swollen, red, hot or painful skin, with or without fever.

You should take calcium and vitamin D supplements as recommended by your healthcare professional.

**Tell your healthcare professional about all the medicines you take, including any drugs, vitamins, minerals, natural supplements or alternative medicines.**

**The following may interact with DENOZA:**

In a drug interaction study, denosumab (60 mg) did not interfere with the action of a drug called midazolam which is metabolized (broken down) by a certain liver enzyme called cytochrome P450 3A4. No drug interactions are expected with DENOZA and other drugs metabolised by this enzyme in women with postmenopausal osteoporosis.

You should discuss with your doctor any medications or vitamins or herbal products you are taking before using DENOZA.

**How to take DENOZA:**

DENOZA is administered as a single injection under the skin (subcutaneous) every 6 months. The injection can be in your upper arm, upper thigh, or abdomen. It can be given any time with or without food by a healthcare professional, by a trained injector, or a patient may self-inject if a healthcare professional determines that is appropriate.

Your prefilled syringe may be left outside the refrigerator for about 30 minutes to reach room temperature (up to 25°C) before injection. This will make the injection more comfortable. Keep the prefilled syringe in the original carton until ready to use in order to protect from light. See instructions for injection.

Keep all medicines, including DENOZA, away from children.

Do not share an DENOZA product with others, even if they have a similar disease.

**Usual dose:**

The usual dose of DENOZA is 60 mg administered once every 6 months. You should also take supplements of calcium and vitamin D.

**Overdose:**

If you think you, or a person you are caring for, have taken too much DENOZA, contact a healthcare professional, hospital emergency department, regional poison control centre or Health Canada's toll-free number, 1-844 POISON-X (1-844-764-7669), immediately, even if there are no signs or symptoms.

**Missed dose:**

If you miss a dose you should receive your next dose as soon as convenient. Schedule

your next dose 6 months from the date of your last injection.

**The following instructions are for preparing and giving an injection of DENOZA using a single-use prefilled syringe with an automatic needle guard:**

### Guide to parts

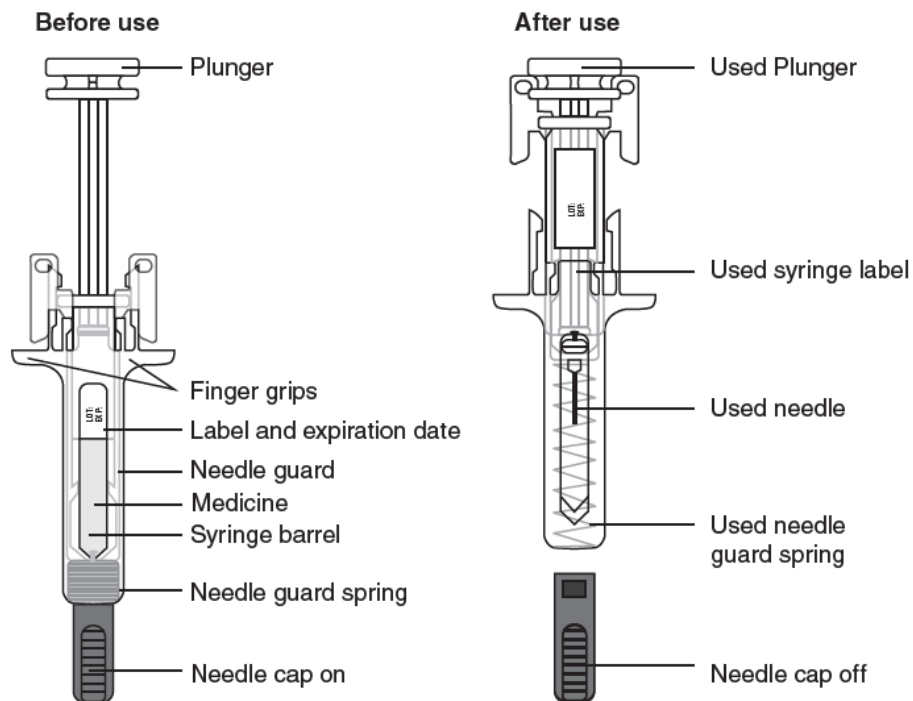

### Important:

Before you use an DENOZA prefilled syringe, read this important information:

### Using the prefilled syringe

- Administration should be performed by an individual who has been trained in injection techniques. This includes patients who have been deemed appropriate by their healthcare professional to administer DENOZA.

If your doctor decides that you or your caregiver may be able to give your injections of DENOZA at home, ensure that your doctor or nurse shows you or your caregiver how to prepare and inject with the DENOZA prefilled syringe before you use it for the first time.

Be sure that you read and understand these Instructions for Use before injecting with the DENOZA prefilled syringe. Talk to your doctor if you have any questions

- Make sure the name DENOZA appears on the carton and prefilled syringe label.

- Check the carton and prefilled syringe label to make sure the dose strength is 60 mg.
- Do NOT use a syringe after the expiration date on the label.
- Do NOT shake the syringe.
- Do NOT open the outer box until you are ready to use this medicine.
- Do NOT remove needle cap from the syringe until you are ready to inject.
- Do NOT use the syringe if the carton is open or damaged.
- Do NOT use a syringe if it has been dropped on a hard surface. Part of the syringe may be broken even if you cannot see the break. Use a new syringe.
- Do NOT attempt to activate the pre-filled syringe prior to injection
- Do NOT attempt to remove the needle guard from the pre-filled syringe.
- The prefilled syringe is not made with natural rubber latex.

Call your healthcare provider if you have any questions.

### Prepare

- A.** Remove the prefilled syringe carton from the refrigerator.

Leave the carton with pre-filled syringe inside at room temperature for about 30 minutes before injecting

- Do NOT use the prefilled syringe if the carton is damaged.
- Do NOT try to warm the prefilled syringe by using a heat source such as hot water or microwave.
- Do NOT leave the prefilled syringe in direct sunlight.
- Do NOT shake the prefilled syringe.

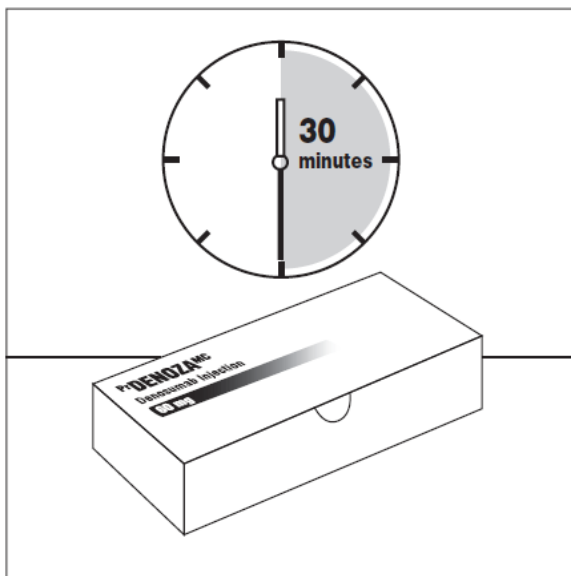

- Wash your hands thoroughly with soap and water.

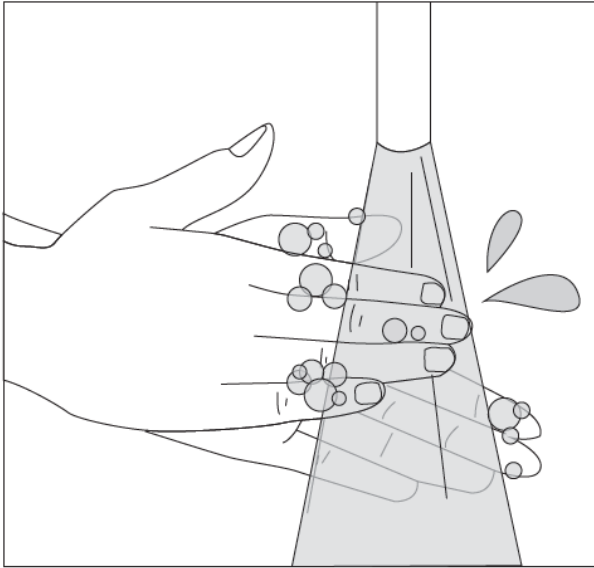

- Open the carton.
- Grab the pre-filled syringe by the body.
- Lift the syringe straight out of the carton
- Put the syringe on a clean and flat work surface

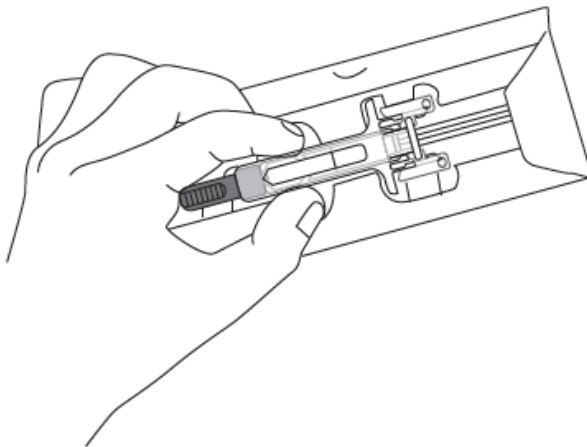

For safety reasons:

- Do NOT grab the plunger rod.

- Do NOT grab the needle cap.
- B.** Inspect the medicine and prefilled syringe.

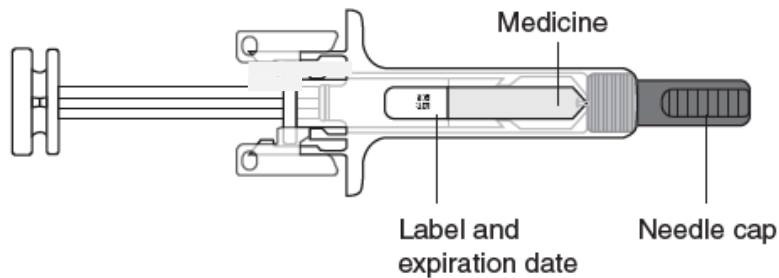

Always hold the syringe by the syringe barrel.

Make sure the medicine in the prefilled syringe is colourless to slightly yellow.

Do NOT use the prefilled syringe if:

- The medicine is cloudy or discoloured.
- Any part appears cracked or broken.
- The prefilled syringe has been dropped.
- The needle cap is missing or not securely attached.
- The expiration date printed on the label has passed.

In all cases, use a new prefilled syringe and call your healthcare professional or Apotex Inc. at 1-800-667-4708.

**C.** Gather all materials needed for the injection.

Wash your hands thoroughly with soap and water.

On a clean, well-lit work surface, place the:

- Prefilled syringe
- Alcohol wipe
- Cotton ball or gauze pad
- Adhesive bandage
- Sharps disposal container

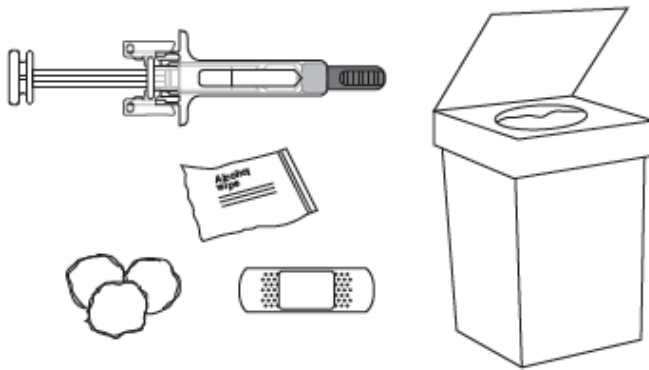

### Get ready

#### D. Prepare and clean the injection site

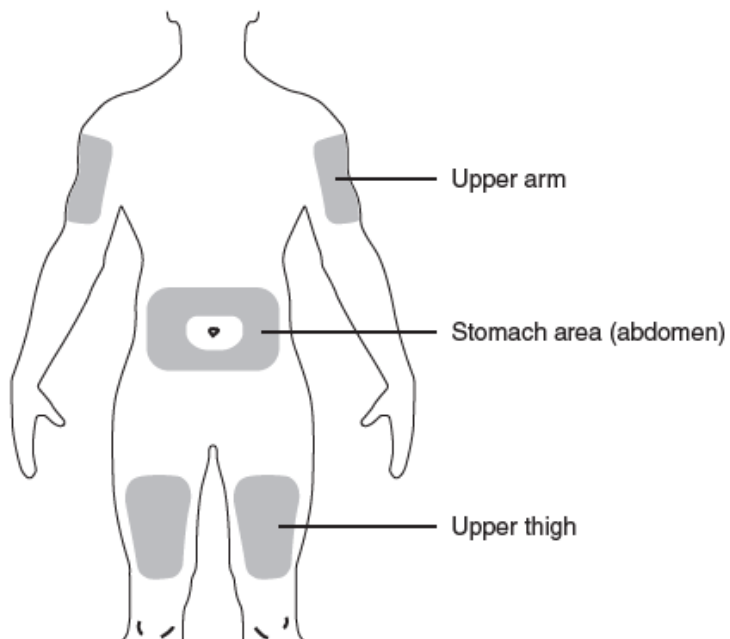

You can use:

- Upper thigh
- Stomach area (abdomen), except for a 5 cm (2-inch) area right around the navel (belly button)
- Outer area of upper arm (only if someone else is giving you the injection).

Clean the injection site with an alcohol wipe. Let the skin dry.

- Do NOT touch this area again before injecting.
- Do NOT inject into areas where the skin is tender, bruised, red, or hard. Avoid injecting

into areas with scars or stretch marks.

- E. Hold the prefilled syringe by the syringe barrel. Carefully pull the needle cap straight off and away from the body.

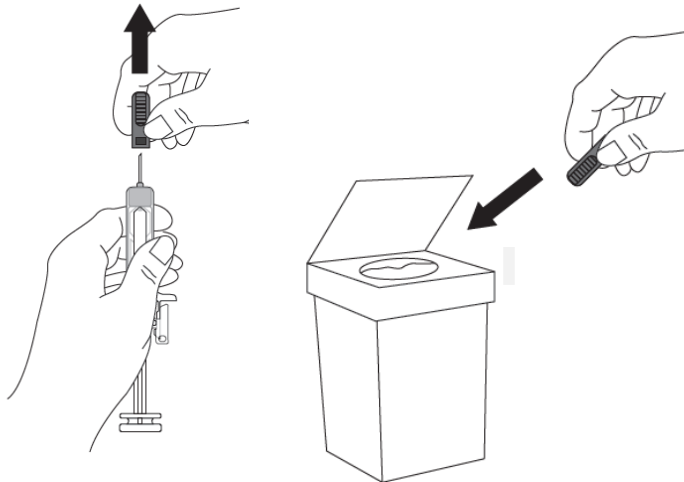

- Do NOT remove the needle cap from the prefilled syringe until you are ready to inject.
- Do NOT twist or bend the needle cap.
- Do NOT hold the prefilled syringe by the plunger rod.
- Do NOT put the needle cap back onto the prefilled syringe.

**Important:** Throw the needle cap into the sharps disposal container.

### Subcutaneous (under the skin) injection.

- F. Pinch the injection site to create a firm surface.



**Important:** Keep skin pinched while injecting.

- G. Hold the pinch. Insert the needle into the skin at 45 to 90 degrees.

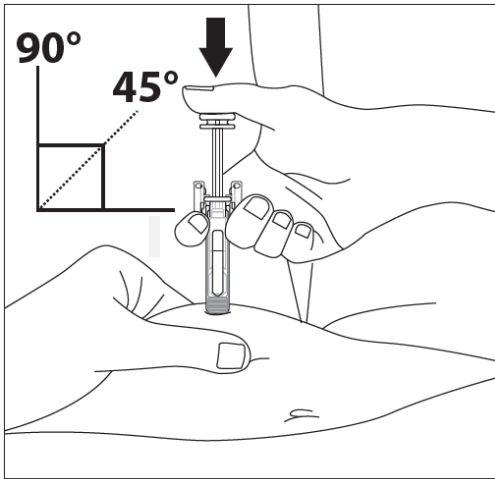

- H. Use slow and constant pressure to push the plunger all the way in until all the liquid is injected, and the syringe is empty

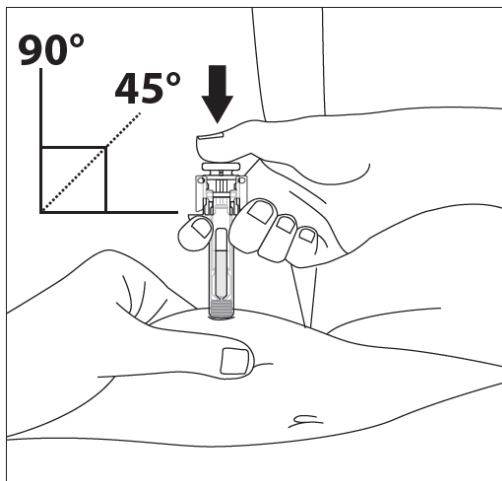

**Note:** The plunger must be pushed all the way down to be sure the full dose has been injected and the needle guard will activate

#### **Release your thumb**

- Take your thumb off the plunger to allow the needle guard to cover the needle.

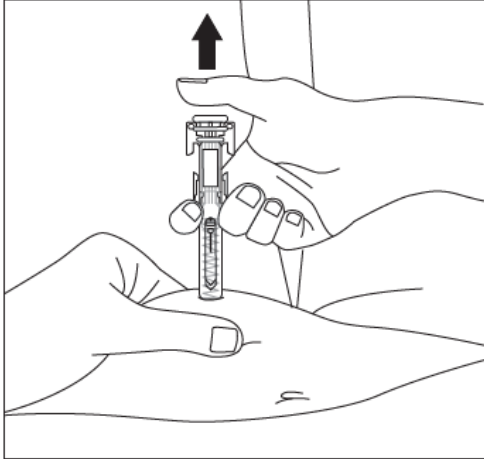

- Then lift the syringe off the skin.

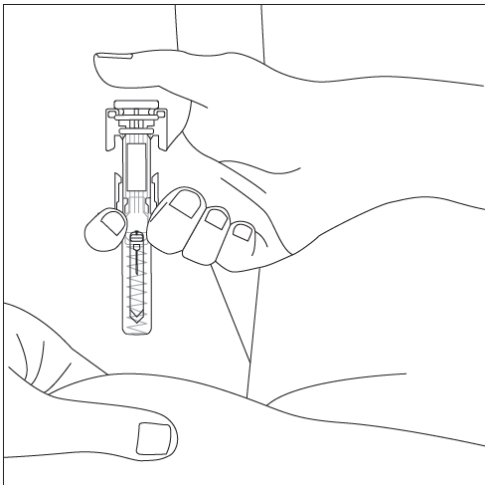

- Release the pinched skin.

**Important:** Call your healthcare professional right away if:

- You remove the syringe and it looks like the medicine is still in the syringe barrel, this means that you did not inject the full dose

Or

- The needle guard does not activate after injecting.

### Finish

- I. Discard (throw away) the used prefilled syringe.

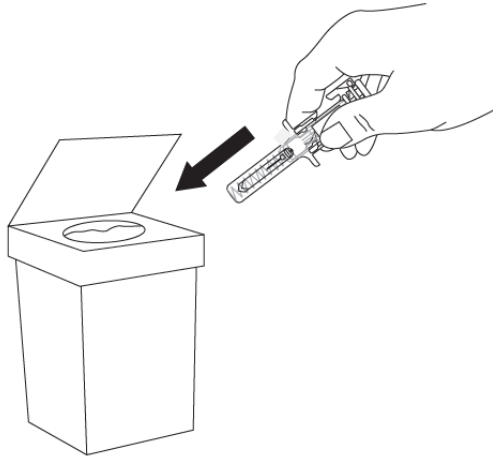

- Put the used prefilled syringe in a sharps disposal container right away after use. Do NOT throw away (dispose of) the syringe in the household trash.
- If you do not have a sharps disposal container, you may use a household container that is:
  - made of a heavy-duty plastic,
  - can be closed with a tight-fitting, puncture-resistant lid, without sharps being able to come out,
  - upright and stable during use,
  - leak-resistant, and
  - properly labeled to warn of hazardous waste inside the container.
- When your sharps disposal container is almost full, you will need to follow your community guidelines for the right way to dispose of your sharps disposal container. There may be state or local laws about how you should throw away used needles and syringes.
- Do NOT reuse the prefilled syringe.
- Do NOT recycle the prefilled syringe or sharps disposal container or throw them into household trash.

**Important:** Always keep the sharps disposal container out of the reach of children.

**J.** Examine the injection site.

If there is blood, press a cotton ball or gauze pad on the injection site. Do NOT rub the injection site. Apply an adhesive bandage if needed.

**K.** Record date of next injection

- Record the date of your next injection on the sticker included on the card, in the

carton and place on your calendar. Your next injection will be 6 months from the date of injection.

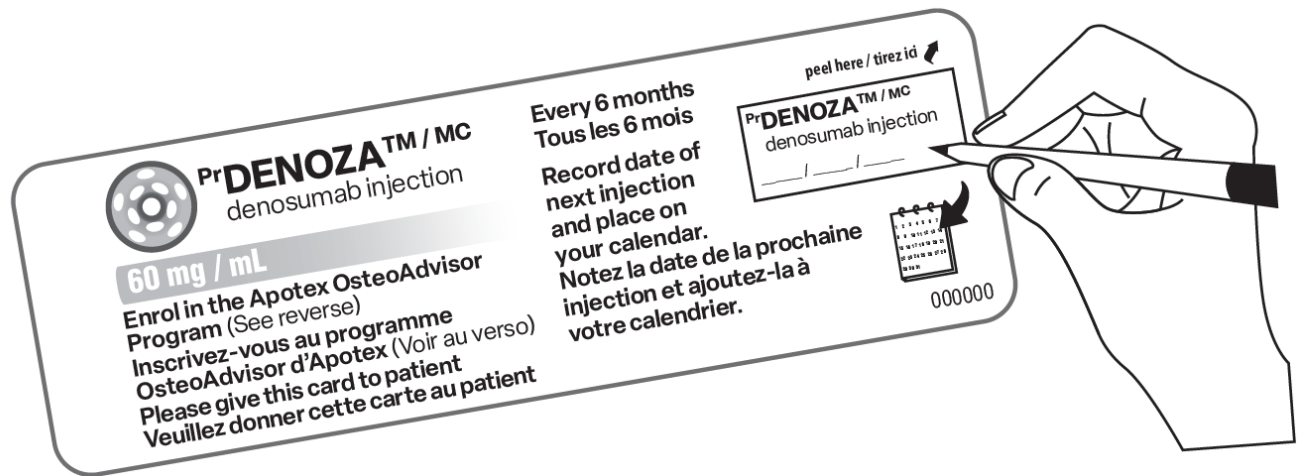

#### Possible side effects from using DENOZA:

Like all medicines, DENOZA can cause side effects, although not everybody gets them.

These are not all the possible side effects you may have when taking DENOZA. If you experience any side effects not listed here, tell your healthcare professional.

Possible side effects include:

- Pain, sometimes severe, in the muscles, joints, arms, legs or back.
- Low blood calcium (hypocalcemia). Symptoms of low blood calcium may include muscle spasms, twitches, cramps, numbness or tingling in fingers, toes or around the mouth.
- Allergic reactions (eg, rash, hives, or in rare cases, swelling of the face, lips, tongue, throat, or trouble breathing).
- Allergic reaction that can damage blood vessels mainly in the skin (eg, purple or brownish- red spots, hives or skin sores)
- Severe allergic reaction (drug reaction with eosinophilia and systemic symptoms [DRESS] syndrome) with skin rash/blisters, fever and/or increase in a type of white blood cell (eosinophils) with possible organ damage, such as liver, kidney, or lung.
- Skin condition with itching, redness and/or dryness (eczema). Injection site reactions were uncommon.
- Rash that may occur on the skin or sores in the mouth (lichenoid drug eruption).
- Hair loss (alopecia).
- Skin infection with swollen, red area of skin, that feels hot and tender and may be accompanied by fever (cellulitis).

- Common cold (runny nose or sore throat).
- Broken bones in the spine after stopping DENOZA (multiple vertebral fractures).

### Serious side effects and what to do about them

Frequency/Side Effect/Symptom	Talk to your healthcare professional		Stop taking this drug and get immediate medical help
	Only if severe	In all cases	
<b>Common</b> ( $\geq 1\%$ , in 1 to 10% of patients)			
Skin condition with itching, redness and/or dryness (eczema)	X		
<b>Uncommon</b> ( $\geq 0.1\%$ , $< 1\%$ )			
Skin infection (mainly cellulitis) leading to hospitalization, erysipelas (serious and rapid skin infection commonly on the face or legs)		X	
Bladder infection, pancreatitis (inflamed pancreas causing severe stomach pains), and ear infection		X	
Broken bones in the spine after stopping DENOZA treatment (multiple vertebral fractures)		X	
<b>Rare</b> ( $\geq 0.01\%$ , $< 0.1\%$ )			
Low calcium levels in the blood (muscle spasms, twitches, cramps, numbness or tingling in hands, feet or around the mouth, and weakness)		X	
Endocarditis (inflammation of the inner lining of the heart)		X	X
Sore in mouth involving gums or jaw bones (osteonecrosis of the jaw)		X	X
Allergic reaction (feeling faint, trouble breathing/wheezing, throat tightness, swelling of face, lips or tongue, rash, hives)		X	X
Unusual thigh bone fractures (atypical femoral fracture)		X	

If you have a troublesome symptom or side effect that is not listed here or becomes bad enough to interfere with your daily activities, tell your healthcare professional.

**Reporting Side Effects**

You can report any suspected side effects associated with the use of health products to Health Canada by:

- Visiting the Web page on Adverse Reaction Reporting ([canada.ca/drug-device-reporting](http://canada.ca/drug-device-reporting)) for information on how to report online, by mail or by fax; or
- Calling toll-free at 1-866-234-2345.

*NOTE: Contact your healthcare professional if you need information about how to manage your side effects. The Canada Vigilance Program does not provide medical advice.*

**Storage:**

Keep out of the reach and sight of children.

When prescribed DENOZA, you will likely need to fill your prescription at a pharmacy. Store DENOZA in your refrigerator at 2°C to 8°C until your injection appointment with your healthcare professional or trained injector. Do not freeze or shake.

When removed from the refrigerator, DENOZA must be kept at room temperature (up to 25°C) in the original carton and must be used within 30 days.

Store in original carton in order to protect from light.

Do not use DENOZA after the expiry date which is printed on the carton and label. The expiry date refers to the last day of that month.

Medicines should not be disposed of via wastewater or household waste. Ask your pharmacist how to dispose of medicines that are no longer required.

**If you want more information about DENOZA:**

- Talk to your healthcare professional
- Find the full product monograph, that is prepared for healthcare professionals and includes this Patient Medication Information by visiting the Health Canada Drug Product Database website ([Drug Product Database: Access the database](http://www.drugproductdatabase.ca)); the manufacturer's website (<http://www.apotex.ca/products>); or by calling 1-800-667-4708.

This leaflet was prepared by Apotex Inc., Toronto, Ontario M9L 1T9

Date of Authorization: March 11, 2026